



QUICK SELECTION / Selezione veloce

input speed (n_1) = 1400 min⁻¹

| Output Speed n_2 [min ⁻¹] | Ratio i | Motor power P_{1M} [kW] | Output torque M_{2M} [Nm] | Service factor f.s. | Nominal power P_{1R} [kW] | Nominal torque M_{2R} [Nm] | Available B5 motor flanges | | | Available B14 motor flanges | | | | Dynamic efficiency RD | Tooth Module [mm] | Ratios code |
|---|--------------|---------------------------------|-----------------------------------|------------------------|-----------------------------------|------------------------------------|----------------------------|----|----|-----------------------------|-----|----|----|---------------------------------|--------------------------|-----------------|
| | | | | | | | -B | -C | -D | -O | -P | -Q | -R | | | |
| | | | | | | | 63 | 71 | 80 | 56 | 63 | 71 | 80 | | | |
| 200 | 7 | 0.75 | 29 | 1.9 | 1.5 | 57 | B | B | | | B-C | B | | 82 | 2.5 | 01 |
| 140 | 10 | 0.75 | 41 | 1.5 | 1.1 | 62 | B | B | | | B-C | B | | 80 | 2.4 | 02 |
| 100 | 14 | 0.75 | 57 | 1.2 | 0.90 | 68 | B | B | | | B-C | B | | 79 | 2.6 | 03 |
| 78 | 18 | 0.55 | 51 | 1.2 | 0.67 | 62 | B | B | | | B-C | B | | 75 | 2.0 | 04 |
| 54 | 26 | 0.55 | 67 | 1.0 | 0.54 | 66 | B | B | | | B-C | B | | 69 | 2.7 | 05 |
| 47 | 30 | 0.55 | 79 | 0.9 | 0.50 | 72 | B | B | | | B-C | B | | 70 | 2.5 | 12 |
| 39 | 36 | 0.37 | 63 | 1.2 | 0.43 | 72 | B | | | B-C | B-C | | | 69 | 2.1 | 06 |
| 33 | 43 | 0.37 | 72 | 1.0 | 0.35 | 68 | B | | | B-C | B-C | | | 66 | 1.8 | 07 |
| 23 | 60 | 0.25 | 59 | 1.0 | 0.26 | 62 | B | | | B-C | B-C | | | 58 | 1.3 | 08 |
| 21 | 68 | 0.25 | 66 | 0.9 | 0.22 | 58 | B | | | B-C | B-C | | | 57 | 1.2 | 09 |
| 17.5 | 80 | 0.18 | 53 | 1.1 | 0.19 | 57 | B | | | B-C | B-C | | | 54 | 1.0 | 10 |
| 14 | 100 | 0.12 | 41 | 1.3 | 0.15 | 51 | B | | | B-C | B-C | | | 50 | 0.8 | 11 |

Motor Flanges Available Flange Motore Disponibili
B) Supplied with Reduction Bushing Fornito con Bussola di Riduzione
B) Available on Request without reduction bushing Disponibile a Richiesta senza Bussola di Riduzione
C) Motor Flange Holes Position Posizione Fori Flangia Motore

EN Unit 050 is supplied with synthetic oil, providing "long life" lubrication. For mounting position V5-V6 please contact us. See table 1 for lubrication and recommended quantity. In table 2 please see possible radial loads and axial loads on the gearbox.

I Il riduttore tipo 050 viene fornito lubrificato a vita con olio sintetico. Per posizioni V5-V6 contattare il ns. servizio tecnico. Vedi tab.1 per oli e quantità consigliati. In tab.2 sono presenti i carichi radiali e assiali applicabili al riduttore.

D Für die Lebensdauerschmierung ist das Getriebe der Größe 050 mit synthetischem Öl befüllt. Bei Einbaulage V5 oder V6 bitten wir um Rücksprache. In Tabelle 1 ist die Schmiermenge und das empfohlene Schmiermittel angegeben. In Tabelle 2 sind die zulässigen Radial - und Axialbelastungen des Getriebes aufgeführt.

F Le réducteur de type 050 est fourni lubrifié à vie avec de l'huile synthétique. Concernant les positions V5.V6, contactez notre service d'assistance technique. Voir tableau 1 concernant les huiles et les quantités conseillées. Les charges radiales et axiales applicables au réducteur sont précisées dans le tableau 2.

E El reductor tamaño 050 se suministra, lubricado de por vida con aceite sintético. Para las posiciones V5 y V6 contactar con nuestro servicio técnico. Ver tabla 1, para cantidades y aceites recomendados. En la tabla 2, se encuentran las cargas radiales y axiales admitidas por el reductor.

LUBRICATION 050 Oil Quantity 0.14 Lt.

AGIP Telium VSF 320

SHELL Omala S4 WE 320

For all details on lubrication and plugs check our website **tab. 1**
Per maggiori dettagli su lubrificazione e tappi olio vedi il nostro sito web

RADIAL AND AXIAL LOADS

Output shaft Albero di uscita

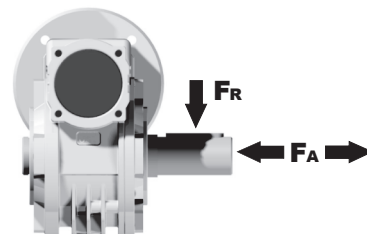

| n_2 [min ⁻¹] | FA [N] | FR [N] |
|-------------------------------|-----------|-----------|
| 200 | 240 | 1200 |
| 150 | 280 | 1400 |
| 100 | 300 | 1500 |
| 75 | 340 | 1700 |
| 50 | 380 | 1900 |
| 25 | 480 | 2500 |
| 15 | 560 | 2800 |

Input shaft albero in entrata

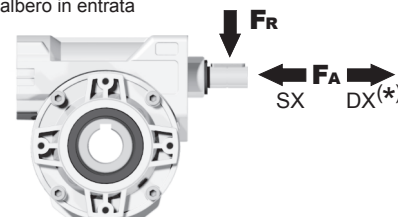

| n_1 [min ⁻¹] | FA [N] | FR [N] |
|-------------------------------|-----------|-----------|
| 1400 | 76 | 380 |

***Strong axial loads in the DX direction are not allowed.**
Non sono consentiti forti carichi assiali con direzione DX

tab. 2

P050FB... Basic wormbox
Riduttore base

Gearbox weight
peso riduttore **3.00 kg**

| M. flanges | Kit code | øF | A |
|--------------|------------|-----|------|
| 63B5 | K050.4.041 | 138 | 78.5 |
| 71B5 | K050.4.042 | 160 | 76 |
| 80B5 | K050.4.043 | 200 | 76.5 |
| 56B14 | KC40.4.049 | 80 | 76 |
| 63B14 | K050.4.047 | 90 | 78.5 |
| 71B14 | K050.4.045 | 105 | 76 |
| 80B14 | K050.4.046 | 120 | 76.5 |

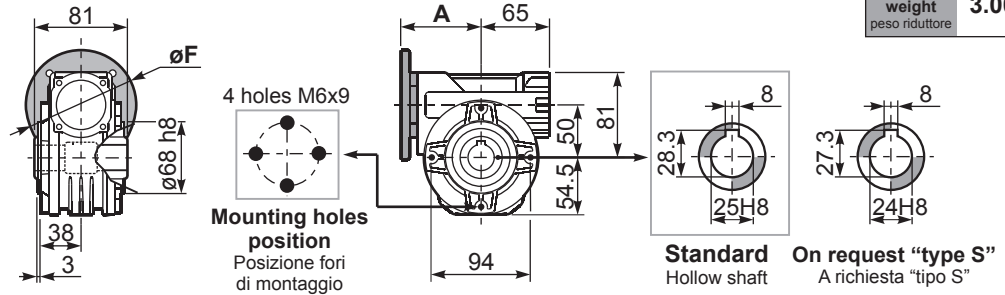

P050PA... Feet
Piedini

P050PB... Feet
Piedini

P050PV... Feet
Piedini

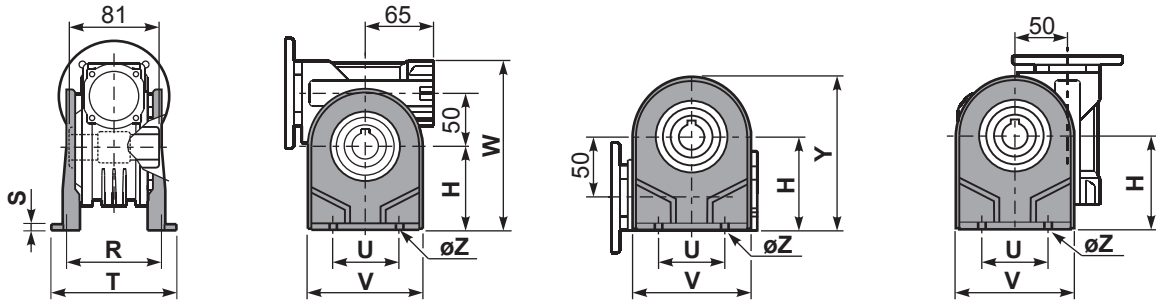

| | H | R | S | T | U | V | Y | W | øZ | kit code |
|--------|----|------|-----|-----|----|-----|-------|-----|-------|-------------|
| type B | 82 | 98.5 | 3.5 | 123 | 63 | 113 | 138.5 | 163 | ø10.5 | K050.9.022 |
| type S | 85 | 96 | 10 | 114 | 85 | 110 | 139.5 | 166 | ø10 | KS050.9.023 |

P050FC... Output flange
Flangia uscita

P050BR... Reaction arm
Braccio di reazione

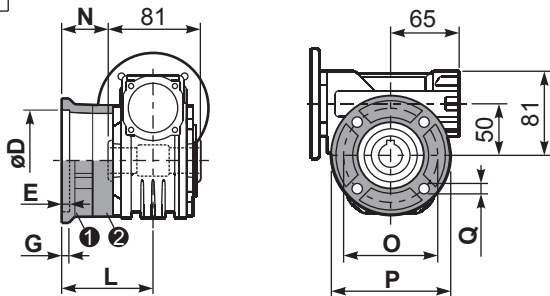

| type B | øD | E | G | L | N | O | P | Q | kit code |
|-----------|--|---|----|-------|------|----|-----|------|------------------------------|
| FC | 70 ^{+0.20} / _{+0.15} | 9 | 12 | 85 | 44.5 | 90 | 123 | 10.5 | 1 K050.9.010 2 - |
| FL | 70 ^{+0.20} / _{+0.15} | 9 | 12 | 114.5 | 74 | 90 | 123 | 10.5 | 1 K050.9.010 2 K050.0.200 |

| type S | øD | E | G | L | N | O | P | Q | kit code |
|-----------|---|---|----|------|----|-----|-----|------|----------------------|
| F1 | 110 ^{+0.20} / _{+0.15} | 4 | 11 | 83.5 | 43 | 130 | 160 | 10 | 1 KS050.9.012 2 - |
| F2 | 70 ^{+0.20} / _{+0.15} | 9 | 12 | 76.5 | 36 | 90 | 123 | 10.5 | 1 KS050.9.014 2 - |
| F3 | 95 ^{+0.035} / ₀ | 4 | 10 | 66.5 | 26 | 115 | 140 | 10 | 1 KS050.9.013 2 - |

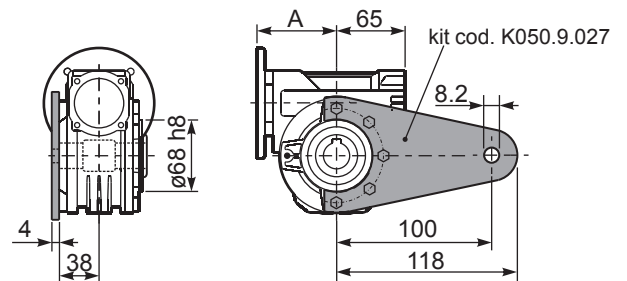

P050.....S... Single Shaft
Albero lento semplice

P050.....D... Double Shaft
Albero lento bisp.

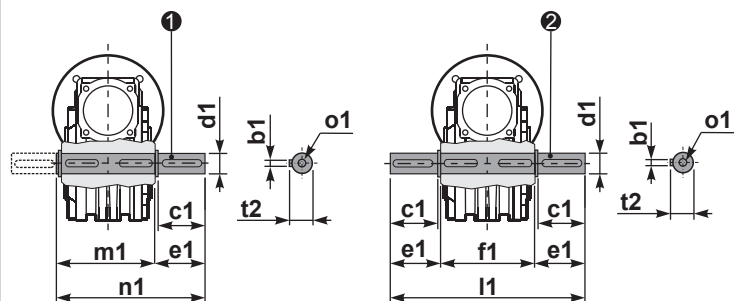

1 kit cod. K050.5.028 type B
kit cod. KS050.5.030 type S

2 kit cod. K050.5.029 type B
kit cod. KS050.5.031 type S

R050FB... Input shaft
Albero in entrata

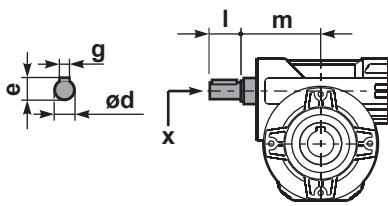

| | ød | e | g | l | m | x | kit code |
|--------|-------|----|---|----|------|-------|--|
| type B | 16 h6 | 18 | 5 | 30 | 74.5 | M6x16 | 1 K050.5.006 PAM71 2 K050.5.007 PAM80 |
| type S | 14 h6 | 16 | 5 | 30 | 74.5 | M5x10 | 1 KS050.5.008 PAM71 2 KS050.5.009 PAM80 |

| | b1 | c1 | d1 | e1 | f1 | l1 | m1 | n1 | t2 | o1 |
|--------|----|----|--|------|----|-----|------|-----|----|-------|
| type B | 8 | 52 | 25 ^{-0.005} / _{-0.020} | 59.5 | 81 | 200 | 86.5 | 146 | 28 | M8x20 |
| type S | 8 | 50 | 24 ^{-0.005} / _{-0.020} | 68.8 | 81 | 218 | 86.5 | 155 | 27 | M8x20 |