

### QUICK SELECTION / Selezione veloce

input speed ( $n_1$ ) = 1400 min<sup>-1</sup>

Output Speed $n_2$ [min <sup>-1</sup> ]	Ratio $i$	Motor power $P_{1M}$ [kW]	Output torque $M_{2M}$ [Nm]	Service factor f.s.	Nominal power $P_{1R}$ [kW]	Nominal torque $M_{2R}$ [Nm]	Available B5 motor flanges				Available B14 motor flanges			Output Shaft 	Ratios code
							-B	-C	-D	-E	-Q	-R	-T		
							63	71	80	90	71	80	90		
15.3	<b>91.23</b>	1.5	858	1.2	1.7	1000	B				C	C		19132418	01
13.4	<b>104.48</b>	1.5	983	1.0	1.5	1000	B				C	C		19132416	02
11.6	<b>121.10</b>	1.5	1139	0.9	1.3	1000	B				C	C		17132416	03
9.9	<b>140.84</b>	1.1	968	1.0	1.1	1000	B				C	C		17132414	04
8.5	<b>165.32</b>	1.1	1136	0.9	0.96	1000	B				C	C		15132414	05
7.6	<b>184.94</b>	0.75	872	1.1	0.86	1000	B				C	C		19082416	06
7.1	<b>197.34</b>	0.75	930	1.1	0.81	1000	B				C	C		13132414	07
6.5	<b>215.10</b>	0.75	1014	1.0	0.74	1000	B				C	C		19082414	08
6.0	<b>231.60</b>	0.55	805	1.2	0.69	1000	B				C	C		10132416	09
5.6	<b>249.31</b>	0.55	867	1.2	0.64	1000	B				C	C		17082414	10
5.2	<b>269.37</b>	0.55	937	1.1	0.59	1000	B				C	C		10132414	11
4.8	<b>292.64</b>	0.55	1018	1.0	0.54	1000	B				C	C		15082414	12
4.6	<b>302.26</b>	0.55	1051	1.0	0.53	1000	B				C	C		9132416	13
4.0	<b>349.30</b>	0.37	812	1.2	0.46	1000	B				C	C		13082414	14
3.5	<b>399.12</b>	0.37	928	1.1	0.40	1000	B				C	C		7132416	15
2.9	<b>476.80</b>	0.37	1108	0.9	0.33	1000	B				C	C		10082414	16
2.2	<b>622.28</b>	0.25	976	1.0	0.26	1000	B				C	C		9082414	17
1.7	<b>821.70</b>	0.18	985	1.0	0.19	1000	B				C	C		7082414	18

standard  
ø40

The dynamic efficiency is **0.92** for all ratios

**Motor Flanges Available**  
Flange Motore Disponibili

**B) Supplied with Reduction Bushing**  
Fornito con Bussola di Riduzione

**B) Available on Request without reduction bushing**  
Disponibile a Richiesta senza Bussola di Riduzione

**C) Motor Flange Holes Position**  
Posizione Fori Flangia Motore

**EN** Unit **X84C** is supplied without lubricant and equipped with a breather, level and drain plugs. User can add mineral oil keeping existing plugs. Should the user wish to fill it with synthetic oil, it is recommended to replace the existing plugs with a closed plug.  
See table 1 for lubrication and recommended quantity.  
In table 2 please see possible radial loads and axial loads on the gearbox.

**I** Il riduttore tipo **X84C** è fornito privo di lubrificazione con tappi di sfiato, livello e scarico olio. L'utente può immettere olio minerale mantenendo i tappi esistenti. Se immetterà olio sintetico, dovrà sostituire i tappi esistenti con altri tipo chiuso.  
Tab.1 per oli e quantità consigliati.  
Tab.2 carichi radiali e assiali applicabili al riduttore.

**D** Das Getriebe der Baugröße **X84C** wird ohne Schmiermittel geliefert. Es ist jedoch mit Einfüllschraube, Überdruckventil und Ablassschraube ausgerüstet. Das benötigte mineralische Öl kann über die Einfüllschraube eingefüllt werden. Sollte synthetisches Öl bevorzugt werden, so ist sind das eingebaute Überdruckventil durch eine geschlossenen Schraube zu ersetzen.  
In Tabelle 1 ist die Schmiermenge und das empfohlene Schmiermittel angegeben  
In Tabelle 2 sind die zulässigen Radial - und Axialbelastungen des Getriebes aufgeführt.

**F** Le réducteur de type **X84C** est fourni sans lubrification et avec un bouchon de remplissage, de niveau et d'évacuation de l'huile. L'utilisateur peut y verser de l'huile minérale en conservant les bouchons existants.  
S'il y versera de l'huile synthétique, il devra substituer les bouchons existants avec d'autres bouchons de type fermé.  
Voir tableau 1 concernant les huiles et les quantités conseillées.  
Voir tableau 2 concernant les charges radiales et axiales applicables au réducteur

**E** El reductor tamaño **X84C** se suministra sin lubricante, provisto de tapones de respiración, nivel y descarga de aceite. El usuario puede utilizar aceite mineral, manteniendo los tapones existentes. Si prefiere utilizar aceite sintético deberá sustituir los tapones existentes por tapones ciegos. La prerreducción se suministra con tapones ciegos, lubricado de por vida con aceite sintético.  
Ver tabla 1, para cantidades y aceites recomendados. En la tabla 2, se encuentran las cargas radiales y axiales admitidas por el reductor.

B3	B6	B7	B8	V5	V6	V8
4.25 LT	3.20 LT	2.10 LT	2.60 LT	5.20 LT	2.90 LT	Ask

**AGIP Blasias 460**

For all details on lubrication and plugs check our website **tab. 1**  
Per maggiori dettagli su lubrificazione e tappi olio vedi il nostro sito web

### RADIAL AND AXIAL LOADS

**Output shaft**  
Albero di uscita

$F_{eq} = FR \cdot \frac{196.5}{X+156.5}$

$n_2$	FA	FR	$n_2$	FA	FR	$n_2$	FA	FR
300	1700	8500	140	1860	9300	70	2160	10800
250	1760	8800	120	1900	9500	40	2300	11500
200	1800	9000	85	1960	9800	15	2400	12000

**On request reinforced bearings to increase loads.**  
A richiesta cuscinetti rinforzati per aumentare i carichi.

**Input shaft**  
Albero in entrata

$n_1$	FA	FR
1400	400	2000
900	440	2200
500	440	2200

**tab. 2**

**PX84CC...** Basic gearbox  
Riduttore base

Gearbox weight  
peso riduttore **46.5 kg**

M. flanges	Kit code	øF	A
<b>63B5</b>	K063.4.041	140	327.7
<b>71B5</b>	K063.4.042	160	325.7
<b>80/90B5</b>	K063.4.043	200	327.7
<b>71B14</b>	K063.4.047	105	325.7
<b>80B14</b>	K063.4.046	120	327.7
<b>90B14</b>	K063.4.041	140	327.7

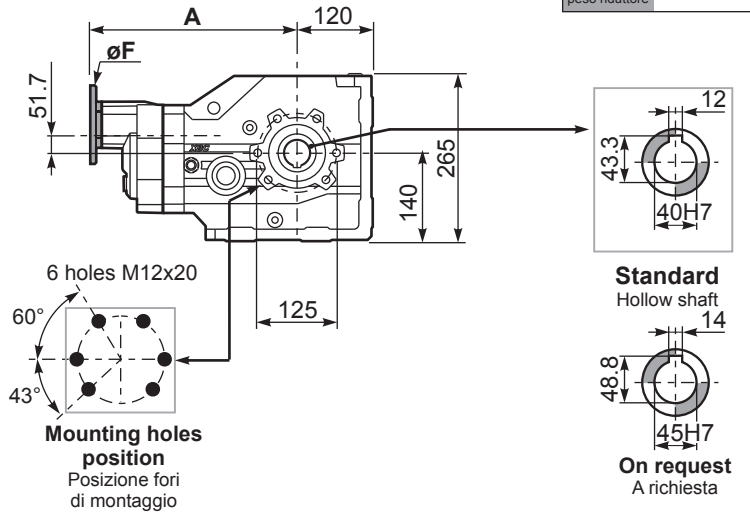
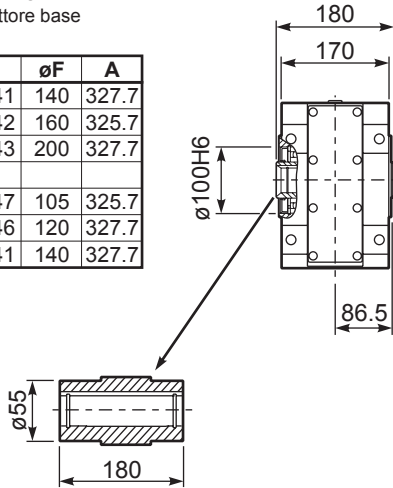

**PX84C...FB..** Feet  
Piedini

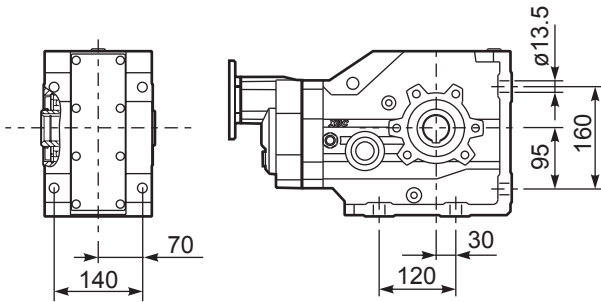

**PX84C...-F4..** Output flange  
Flangia uscita

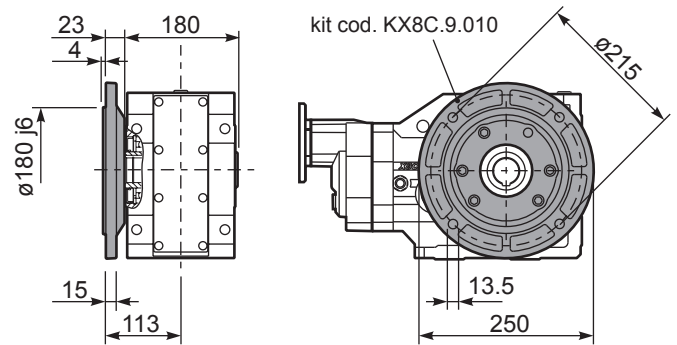

**PX84C...BR..** Reaction Arm  
Braccio di reazione

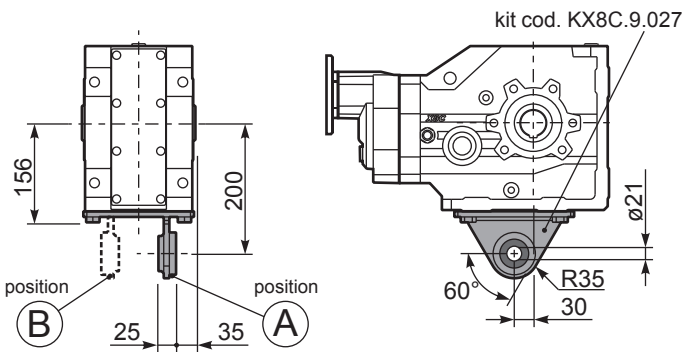

**RX84C...** Input shaft  
Albero in entrata

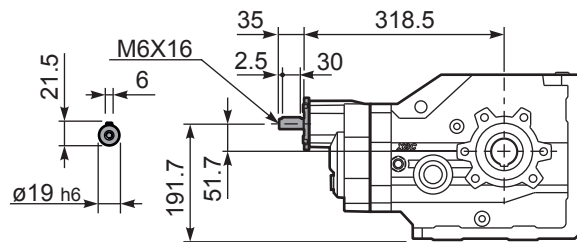

**PX84CA...** Single shaft  
Albero lento semplice

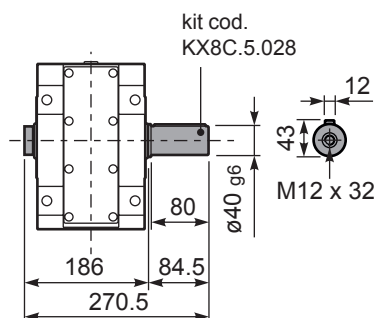

**PX84CB...** Double shaft  
Albero lento bisp.

