

QUICK SELECTION / Selezione veloce The dynamic efficiency is **0.94** for all ratios **input speed (n₁) = 1400 min⁻¹**

Output Speed n ₂ [min ⁻¹]	Ratio i	Motor power P _{1M} [kW]	Output torque M _{2M} [Nm]	Service factor f.s.	Nominal power P _{1R} [kW]	Nominal torque M _{2R} [Nm]	Available B5 motor flanges				Available B14 motor flanges			Output Shaft 	Ratios code
							-B	-C	-D	-E	-Q	-R	-T		
							63	71	80	90	71	80	90		
24.7	56.76	1.1	398	1.0	1.1	410	B				C	C		191311	01
21.3	65.79	0.75	316	1.3	0.97	410	B				C	C		171311	02
18.1	77.23	0.75	371	1.1	0.83	410	B				C	C		151311	03
16.0	87.23	0.75	420	1.0	0.73	410	B				C	C		19138	04
15.2	92.18	0.75	443	0.9	0.69	410	B				C	C		131311	05
13.9	100.47	0.55	357	1.2	0.64	410	B				C	C		19811	06
12.0	116.45	0.55	413	1.0	0.55	410	B				C	C		17811	07
11.1	125.82	0.55	446	0.9	0.51	410	B				C	C		101311	08
9.9	141.66	0.37	336	1.2	0.45	410	B				C	C		13138	09
8.6	163.16	0.37	387	1.1	0.39	410	B				C	C		13811	10
7.8	178.96	0.37	424	1.0	0.36	410	B				C	C		1788	11
7.2	193.36	0.37	459	0.9	0.33	410	B				C	C		10138	12
6.5	216.84	0.25	347	1.2	0.29	410	B				C	C		71311	13
5.5	252.36	0.25	404	1.0	0.25	410	B				C	C		9138	14
4.8	290.67	0.25	465	0.9	0.22	410	B				C	C		9811	15
4.2	333.23	0.18	408	1.0	0.19	410	B				C	C		7138	16
3.6	383.82	0.18	470	0.9	0.17	410	B				C	C		7811	17
3.1	446.70	0.12	353	1.2	0.14	410	B				C	C		988	18
2.4	589.85	0.12	466	0.9	0.11	410	B				C	C		788	19

Motor Flanges Available Flange Motore Disponibili
 B) Supplied with Reduction Bushing Fornito con Bussola di Riduzione
 B) Available on Request without reduction bushing Disponibile a Richiesta senza Bussola di Riduzione
 C) Motor Flange Holes Position Posizione Fori Flangia Motore

EN Unit **X63A** is supplied with synthetic oil for lifetime lubrication, no maintenance is necessary. See table 1 for lubrication and recommended quantity. In table 2 please see possible radial loads and axial loads on the gearbox.

I Il riduttore **X63A** viene fornito completo di olio sintetico per la lubrificazione permanente e non necessita di alcuna manutenzione. Vedi tab.1 per oli e quantità consigliati. In tab.2 sono presenti i carichi radiali e assiali applicabili al riduttore.

D Das Getriebe **X63A** ist mit synthetischem Öl gefüllt und ist lebensdauer geschmiert. In Tabelle 1 ist die Schmiermenge und das empfohlene Schmiermittel angegeben. In Tabelle 2 sind die zulässigen Radial- und Axialbelastungen des Getriebes aufgeführt.

F Le réducteur **X63A** est fourni complet avec de l'huile synthétique pour la lubrification permanente et ne nécessite aucun entretien. Voir tableau 1 concernant les huiles et les quantités conseillées. Les charges radiales et axiales applicables au réducteur sont précisées dans le tableau 2.

E El reductor tamaño **X63A** se suministra, lubricado de por vida con aceite sintético y no requieren mantenimiento alguna. Ver tabla 1, para cantidades y aceites recomendados. En la tabla 2, se encuentran las cargas radiales y axiales admitidas por el reductor.

Standard supplied	For these mounting position specify in the order or add oil Per queste posizioni specificare in fase d'ordine o aggiungere olio						
1.80 LT	1.80 LT	1.05 LT	1.70 LT	2.60 LT	1.65 LT	Ask	
AGIP Telium VSF 320				SHELL Omala S4 WE 320			

For all details on lubrication and plugs check our website **tab. 1**
Per maggiori dettagli su lubrificazione e tappi olio vedi il nostro sito web

RADIAL AND AXIAL LOADS

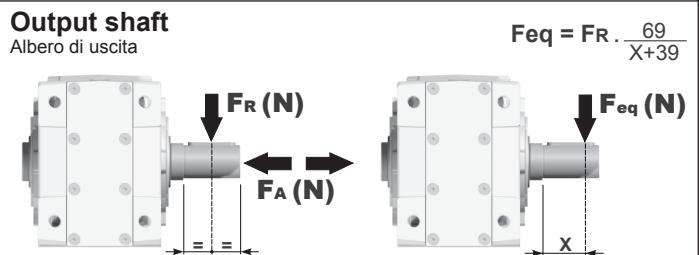

n ₂ [min ⁻¹]	FA	FR	n ₂ [min ⁻¹]	FA	FR	n ₂ [min ⁻¹]	FA	FR
250	600	3000	75	890	4450	15	1660	8300
150	700	3500	50	1140	5700			
100	780	3900	25	1330	6650			

F_R On request taper roller bearings to increase radial loads.
A richiesta cuscinetti a rulli conici per aumentare i carichi radiali.

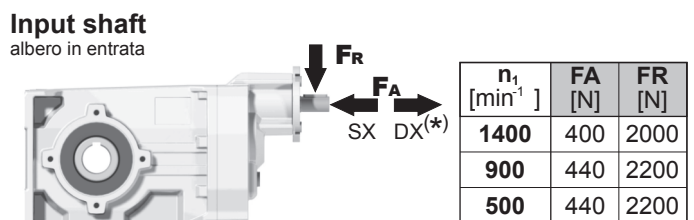

*Strong axial loads in the DX direction are not allowed.
Non sono consentiti forti carichi assiali con direzione DX

tab. 2

PX63AC... Basic Gearbox
Riduttore base

Gearbox weight
peso riduttore **15.98 kg**

M. flanges	Kit code	øF	A
63B5	K063.4.041	140	265
71B5	K063.4.042	160	263
80/90B5	K063.4.043	200	265
71B14	K063.4.047	105	263
80B14	K063.4.046	120	265
90B14	K063.4.041	140	265

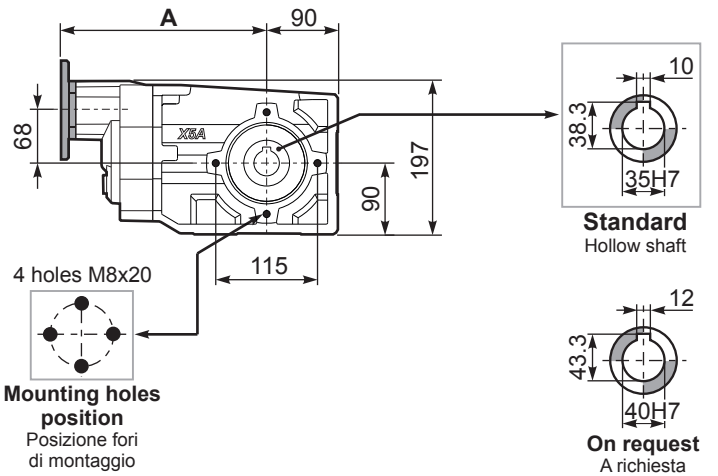
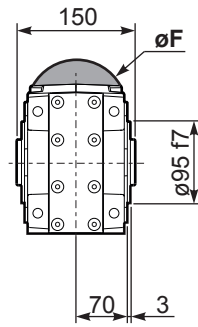

PX63A...FB.. Feet
Piedini

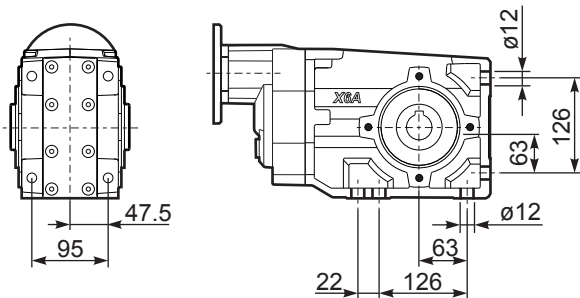

PX63A...-F2.. Output flange
Flangia uscita

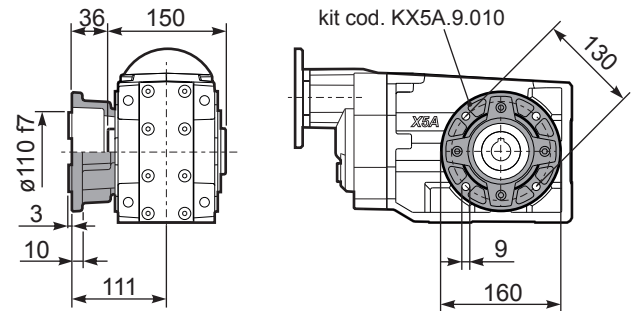

PX63A...-F3.. Output flange
Flangia uscita

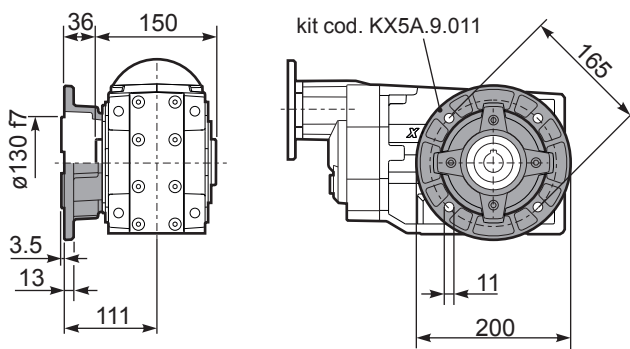

PX63A...-F4.. Output flange
Flangia uscita

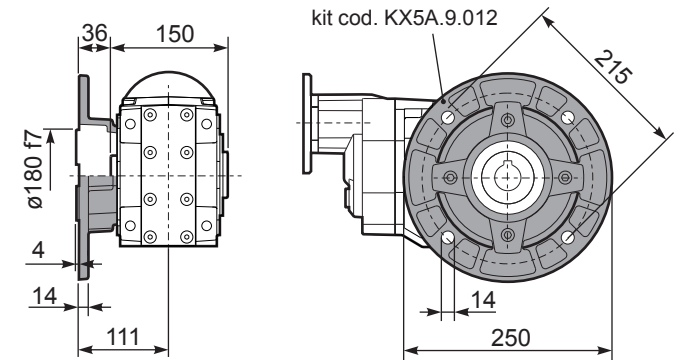

RX63A... Input shaft
Albero in entrata

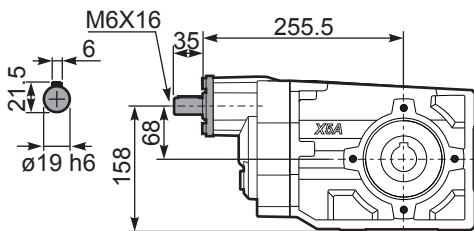

PX63A...BR.. Reaction Arm
Braccio di reazione

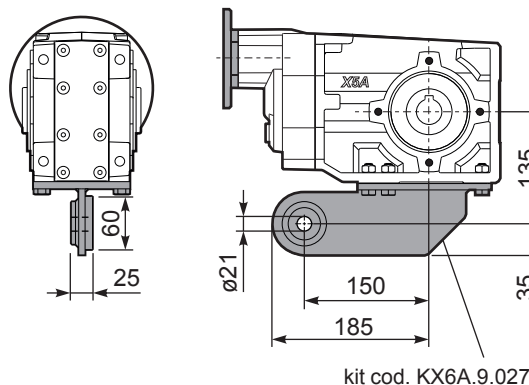

PX63AA.. Single output shaft
Albero semplice in uscita

