

I...B

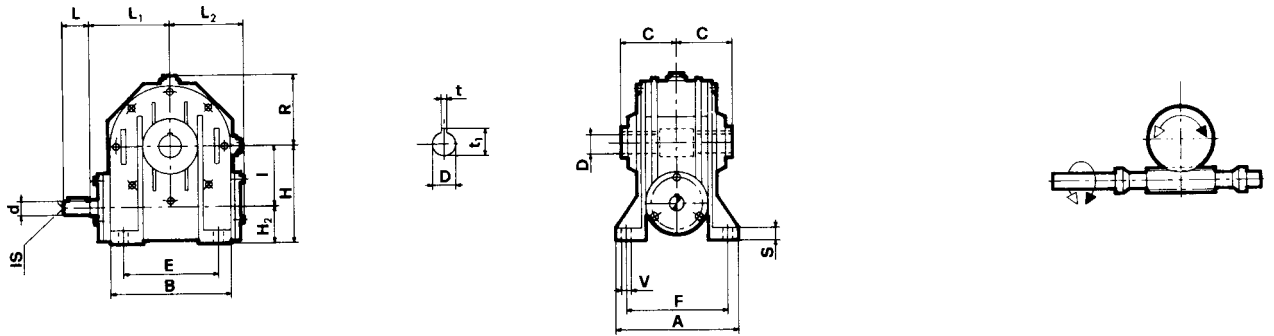

I...A

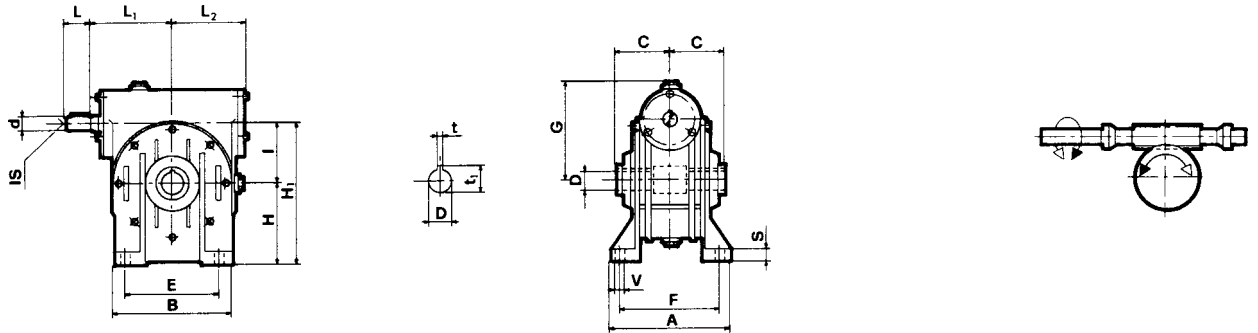

I...V

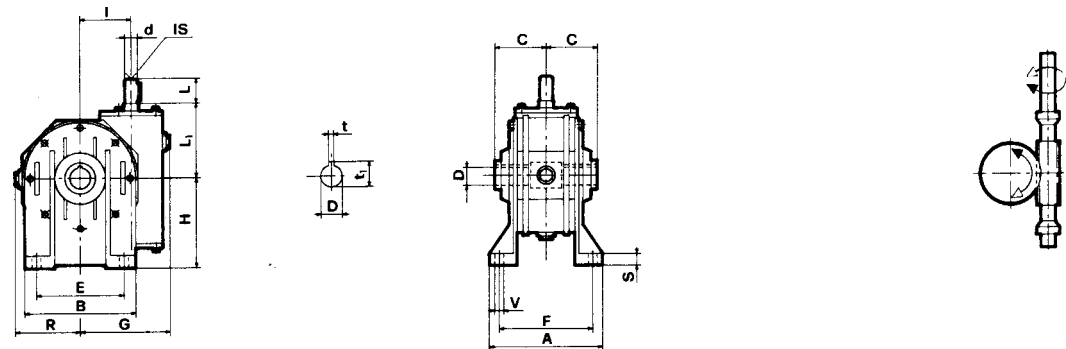

	A	B	E	F	S	V	d J6	G	H	H <sub>1</sub>	H <sub>2</sub>	I	I <sub>s</sub>	L	L <sub>1</sub>	L <sub>2</sub>	R	C	D H7	t	t <sub>1</sub>
<b>80</b>	181	180	140	146	13	11	24	127	142	222	62	80	M8	50	110	105	95	70	35	10	38,3
<b>90</b>	198	210	160	164	15	13	24	139	150	240	60	90	M8	50	126	124	111	75	38	10	41,3
<b>110</b>	190	250	200	160	18	13	28	170	172	282	62	110	M8	60	148	144	141	77,5	42	12	45,3
<b>130</b>	225	280	240	190	18	15	38	194	200	330	70	130	M10	80	167	160	155	95	48	14	51,8
<b>150</b>	260	334	280	220	20	19	42	225	230	380	80	150	M12	110	193	190	182	110	55	16	60,3
<b>175</b>	280	358	310	240	30	19	42	258	260	435	85	175	M12	110	210	204	203	115	60	18	64,4

I...FP

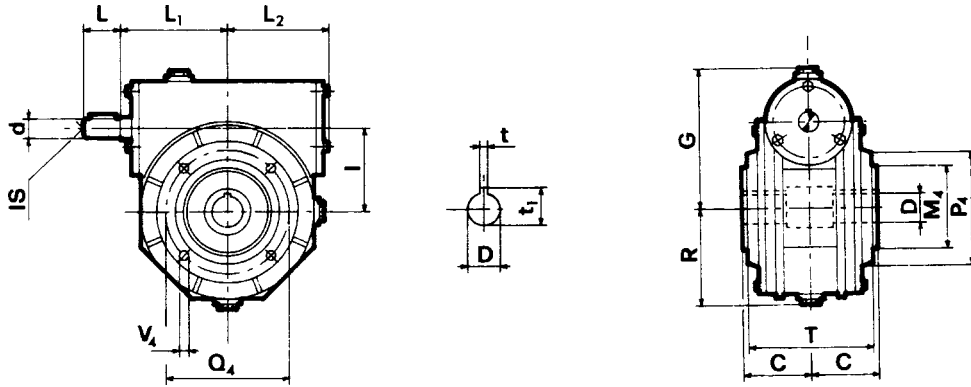

I...F

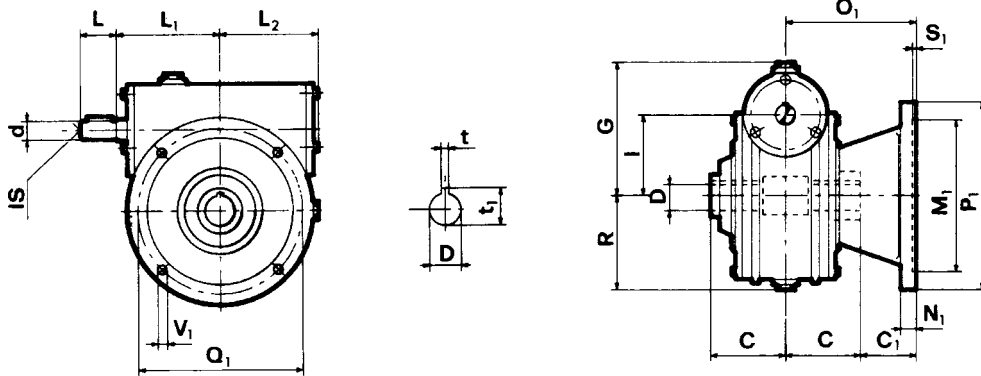

I...FBR

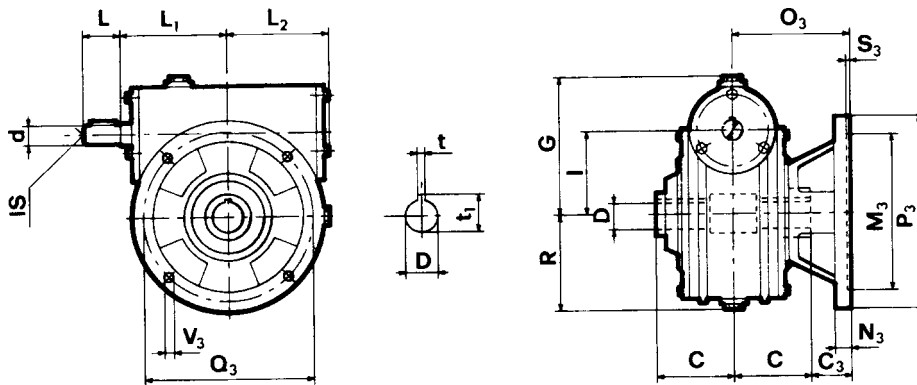

	C <sub>1</sub>	C <sub>3</sub>	M <sub>1</sub> G6	M <sub>3</sub> G6	M <sub>4</sub> G6	N <sub>1</sub>	N <sub>3</sub>	O <sub>1</sub>	O <sub>3</sub>	P <sub>1</sub>	P <sub>3</sub>	P <sub>4</sub>	Q <sub>1</sub>	Q <sub>3</sub>	Q <sub>4</sub>	S <sub>1</sub>	S <sub>3</sub>	V <sub>1</sub>	V <sub>3</sub>	V <sub>4</sub>	d J6	G	I	I <sub>s</sub>	L	L <sub>1</sub>	L <sub>2</sub>	R	T	C	D H7	t	t <sub>1</sub>
80	10	30	130	110	110	13	13	120	100	200	160	145	165	130	130	5	5	11,5	11,5	M10	24	127	80	M8	50	110	105	95	133	70	35	10	38,3
90	52	40	180	130	110	14	15	127	115	250	200	160	215	165	130	5	5	14	11	M10	24	139	90	M8	50	126	124	111	143	75	38	10	41,3
110	72,5	52,5	180	180	130	18	18	150	130	250	250	200	215	215	165	5	5	15	15	M12	28	170	110	M8	60	148	144	141	148	77,5	42	12	45,3
130	55	42,5	230	230	180	18	18	150	137,5	300	300	240	265	265	215	5	5	15	15	M12	38	194	130	M10	80	167	160	155	172	95	48	14	51,8
150	65	-	250	-	180	20	-	175	-	350	-	250	300	-	215	6	-	17	-	M14	42	225	150	M12	110	193	190	182	204	110	55	16	60,3
175	95	-	300	-	230	22	-	210	-	400	-	300	350	-	265	6	-	18	-	M16	42	258	175	M12	110	210	204	203	222	115	60	18	64,4

MI 80 ÷ 175

MI 80 ÷ 175

MI 80 ÷ 175

MI...B

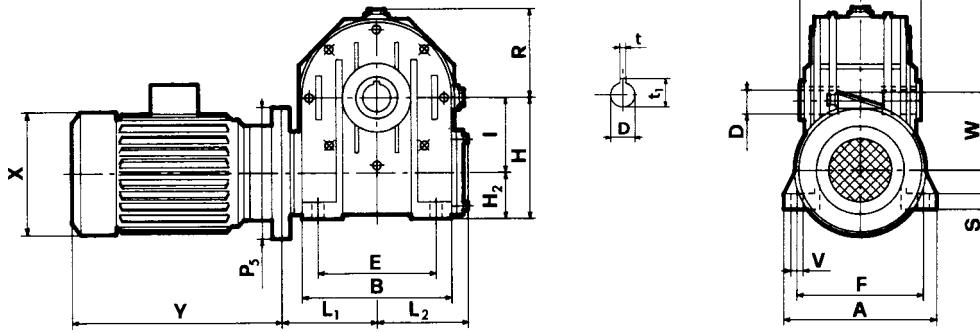

MI...A

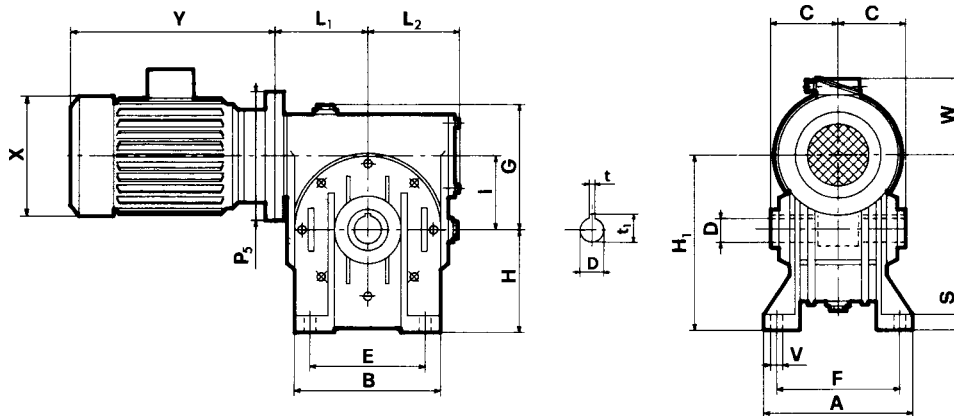

MI...V

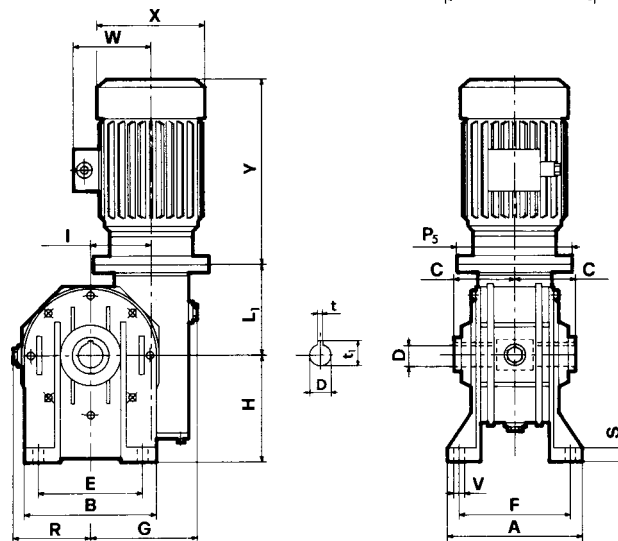

	A	B	E	F	S	V	G	H	H <sub>1</sub>	H <sub>2</sub>	I	L <sub>1</sub>	L <sub>2</sub>	R	C	D H7	t	t <sub>1</sub>
<b>80</b>	181	180	140	147	13	11	127	142	222	62	80	108	105	95	70	35	10	38,3
<b>90</b>	198	210	160	164	15	13	139	150	240	60	90	128	124	111	75	38	10	41,3
<b>110</b>	190	250	200	160	18	13	170	172	282	62	110	149	144	141	77,5	42	12	45,3
<b>130</b>	225	280	240	190	18	15	194	200	330	70	130	165	160	155	95	48	14	51,8
<b>150</b>	260	334	280	220	20	19	225	230	380	80	150	192	190	182	110	55	16	60,3
<b>175</b>	280	358	310	240	30	19	258	260	435	85	175	213	204	203	115	60	18	64,4

NOTA: P<sub>5</sub>, X, Y, W - vedi tabelle motori in B5.

NOTE: P<sub>5</sub>, X, Y, W - see motors table B5.

HINWEIS: P<sub>5</sub>, X, Y, W - siehe Motorentabellen in B5.

MI...FP

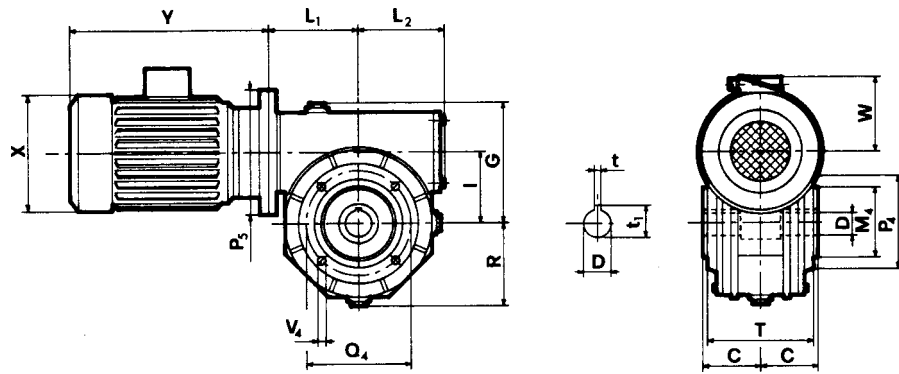

MI...F

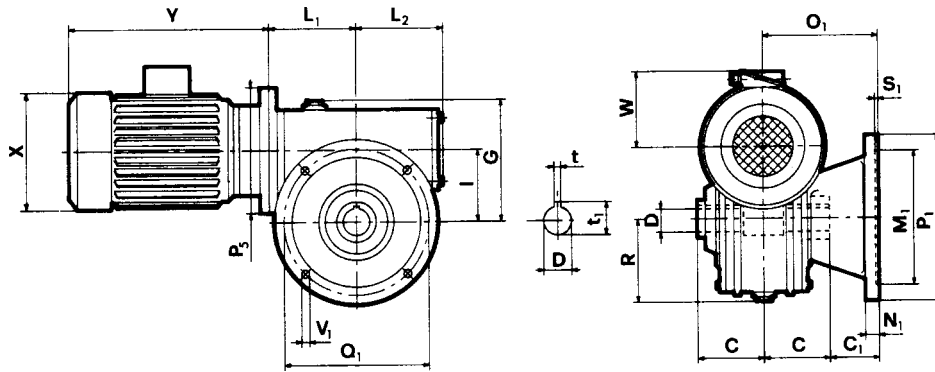

MI...FBR

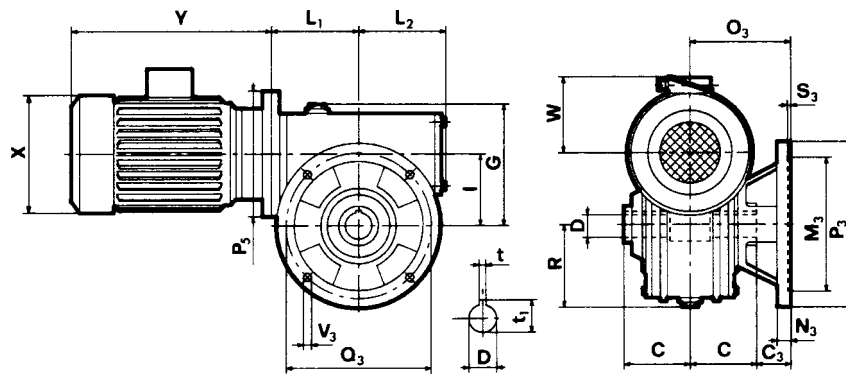

	C <sub>1</sub>	C <sub>3</sub>	M <sub>1</sub> G6	M <sub>3</sub> G6	M <sub>4</sub> G6	N <sub>1</sub>	N <sub>3</sub>	O <sub>1</sub>	O <sub>3</sub>	P <sub>1</sub>	P <sub>3</sub>	P <sub>4</sub>	Q <sub>1</sub>	Q <sub>3</sub>	Q <sub>4</sub>	S <sub>1</sub>	S <sub>3</sub>	V <sub>1</sub>	V <sub>3</sub>	V <sub>4</sub>	G	I	L <sub>1</sub>	L <sub>2</sub>	R	T	C	D H7	t	t <sub>1</sub>
80	50	30	130	110	110	13	13	120	100	200	160	145	165	130	130	5	5	11,5	11,5	M10	127	80	108	105	95	133	70	35	10	38,3
90	52	40	180	130	110	14	15	127	115	250	200	160	215	165	130	5	5	14	11	M10	139	90	128	124	111	143	75	38	10	41,3
110	72,5	52,5	180	180	130	18	18	150	130	250	250	200	215	215	165	5	5	15	15	M12	170	110	149	144	141	148	77,5	42	12	45,5
130	55	42,5	230	230	180	18	18	150	137,5	300	300	240	265	265	215	5	5	15	15	M12	194	130	165	160	155	172	95	48	14	51,8
150	65	-	250	-	180	20	-	175	-	350	-	250	300	-	215	6	-	17	-	M14	225	150	192	190	182	204	110	55	16	60,3
175	95	-	300	-	230	22	-	210	-	400	-	300	350	-	265	6	-	18	-	M16	258	175	213	204	203	222	115	60	18	64,4

NOTA: P<sub>5</sub>, X, Y, W - vedi tabelle motori in B5.

NOTE: P<sub>5</sub>, X, Y, W - see motors table B5.

HINWEIS: P<sub>5</sub>, X, Y, W - siehe Motorentabellen in B5.