

50/2-50/3	G	G1	G2	F	F1	F2	F3	F4	H
/2...90 B5 /2F...90 B5	24	27,3	8	200	165	130	15	11,5	473
/2...100-112 B5 /2F...100-112 B5	28	31,3	8	250	215	180	15	14	476
/2...132 B5 /2F...132 B5	38	41,3	10	300	265	230	15	14	476
/2...160 B5 /2F...160 B5	42	45,3	12	350	300	250	19	18	506
/3...63 B5 /3F...63 B5	11	12,5	4	140	115	95	12	9	454
/3...71 B5 /3F...71 B5	14	16,3	5	160	130	110	10	9	459
/3...80 B5 /3F...80 B5	19	21,8	6	200	165	130	11	11	453
/3...90 B5 /3F...90 B5	24	27,3	8	200	165	130	11	11	453
/3...100-112 B5 /3F...100-112 B5	28	31,3	8	250	215	180	12	13	456

P = 300							
N	C	M	P	alpha	S	S1	U
230	110	265	300	45°	12	4	14

P = 350							
N	C	M	P	alpha	S	S1	U
250	107	300	350	45°	16	5	18

P = 350							
N	C	M	P	alpha	S	S1	U
250	150	300	350	48°	16	5	18

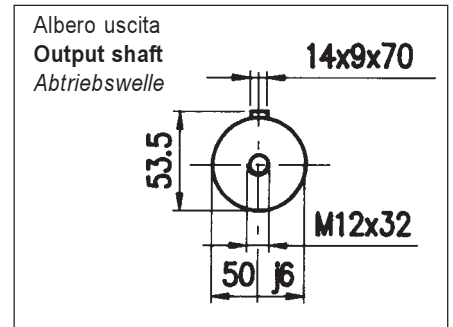
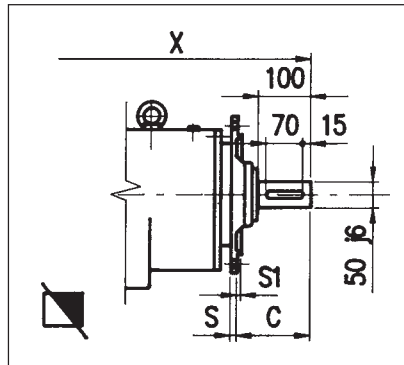
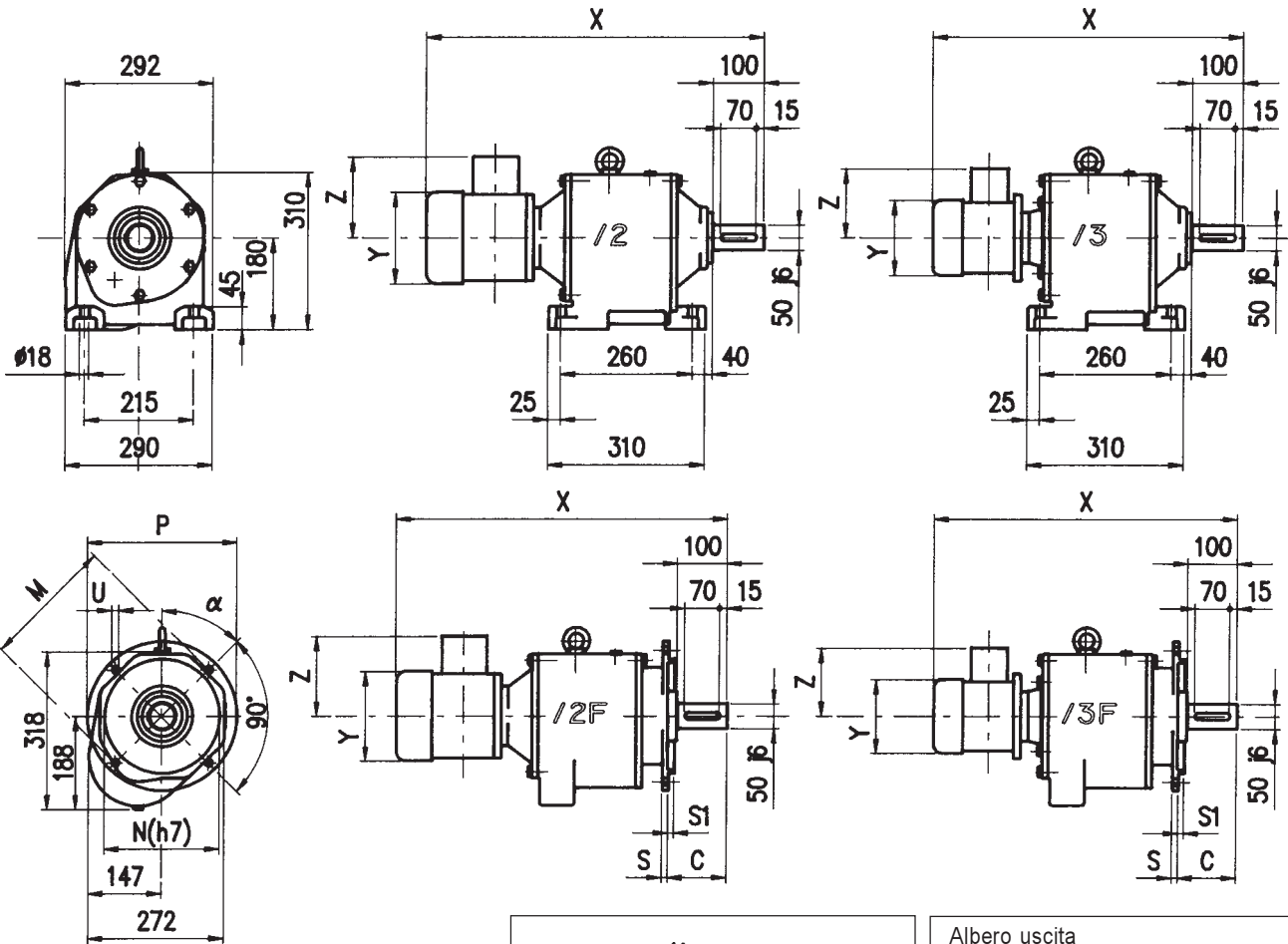

50/2-50/3	Y	Z	X
/2....GR 90 /2F....GR 90	171	121	671
/2....GR 100 /2F....GR 100	193	138	691
/2....GR 112 /2F....GR 112	217	151	709
/2....GR 132 /2F....GR 132	259	180	780
/3....GR 63 /3F....GR 63	124	92	619
/3....GR 71 /3F....GR 71	140	102	624
/3....80 /3F....80	160	115	651
/3....90 /3F....90	171	121	687
/3....100 /3F....100	193	138	707

P = 300							
N	C	M	P	$\alpha$	S	S1	U
230	110	265	300	45°	12	4	14

P = 350							
N	C	M	P	$\alpha$	S	S1	U
250	107	300	350	45°	16	5	18

P = 350							
N	C	M	P	$\alpha$	S	S1	U
250	150	300	350	48°	16	5	18