

# VAR

**MOTOVARIATORI**  
**MOTOVARIATORS**  
**MOTOVARIATEURS**  
**VERSTELLGETRIEBEMOTOREN**  
**MOTOVARIADORES**  
电机变速器



**MOTOVARIO**<sup>®</sup>  
HEART OF MOTION

Funzionamento / Running / Fonctionnement /  
Funktion / Funcionamiento / 运行

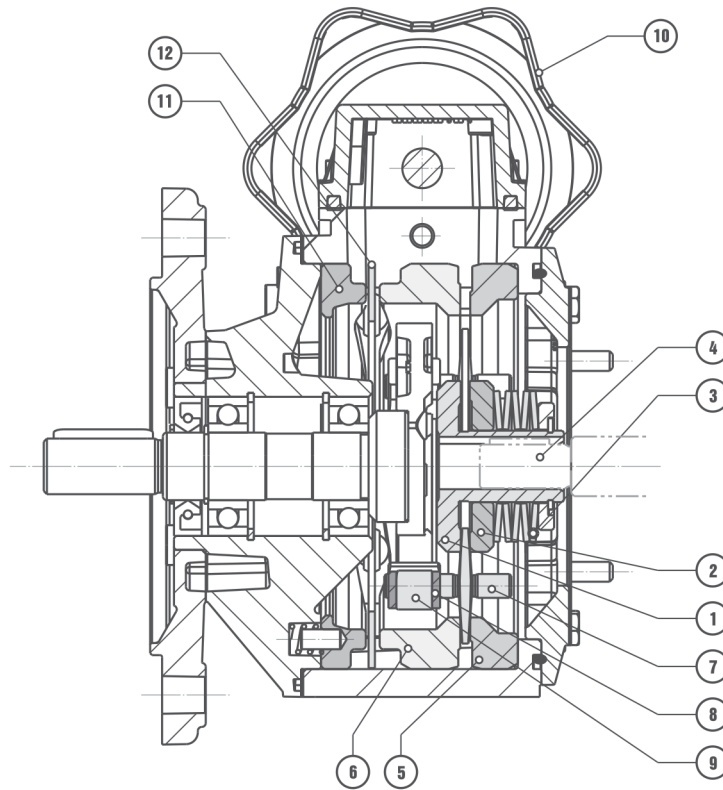

Funzionamento

IT

- 1 Pista interna fissa
- 2 Pista interna mobile
- 3 Molla a tazza
- 4 Albero
- 5 Pista esterna fissa
- 6 Pista esterna mobile
- 7 Satellite
- 8 Boccola satellite
- 9 Porta satellite
- 10 Volantino di comando
- 11 Pista esterna di registro
- 12 Anello portasfere

Running

UK

- 1 Fixed sun race
- 2 Adjustable sun race
- 3 Belleville spring
- 4 Shaft
- 5 Fixed annulus race
- 6 Adjustable annulus race
- 7 Planet disc
- 8 Planet disc friction bearing
- 9 Planet carrier
- 10 Control Handwheel
- 11 Cam ring
- 12 Ball ring

Fonctionnement

FR

- 1 Piste interne fixe
- 2 Piste interne mobile
- 3 Rondelles Belleville
- 4 Arbre
- 5 Piste externe fixe
- 6 Piste externe mobile
- 7 Satellite
- 8 Palier de satellite
- 9 Porte satellites
- 10 Volant de commande
- 11 Piste Cam
- 12 Cage à Billes

Funktion

DE

- 1 Laufring innen feststehend
- 2 Laufring innen verschiebbar
- 3 Tellerfeder
- 4 Welle
- 5 Laufring aussen feststehend
- 6 Laufring aussen verschiebbar
- 7 Satellit
- 8 Satelliten Gleitlager
- 9 Planetenträger
- 10 Verstelleinheit Handrad
- 11 Nockenring feststehend
- 12 Kugelhäufig

Funcionamiento

ES

- 1 Pista interna fija
- 2 Pista interna móvil
- 3 Muelles belleville
- 4 Eje
- 5 Pista externa fija
- 6 Pista externa móvil
- 7 Satélite
- 8 Pastilla satélite
- 9 Portasatélite
- 10 Volante de mando
- 11 Pista Cam
- 12 Corona de bolas

运行

CN

- 1 固定太阳滚道
- 2 可调太阳滚道
- 3 盘形弹簧
- 4 主轴
- 5 固定环形滚道
- 6 可调环形滚道
- 7 行星盘
- 8 行星盘摩擦轴承
- 9 行星轮架
- 10 控制旋牛
- 11 凸轮圈
- 12 滚珠环

**S - Designazione / Designation / Désignation /  
Bezeichnung / Designación / 名称**

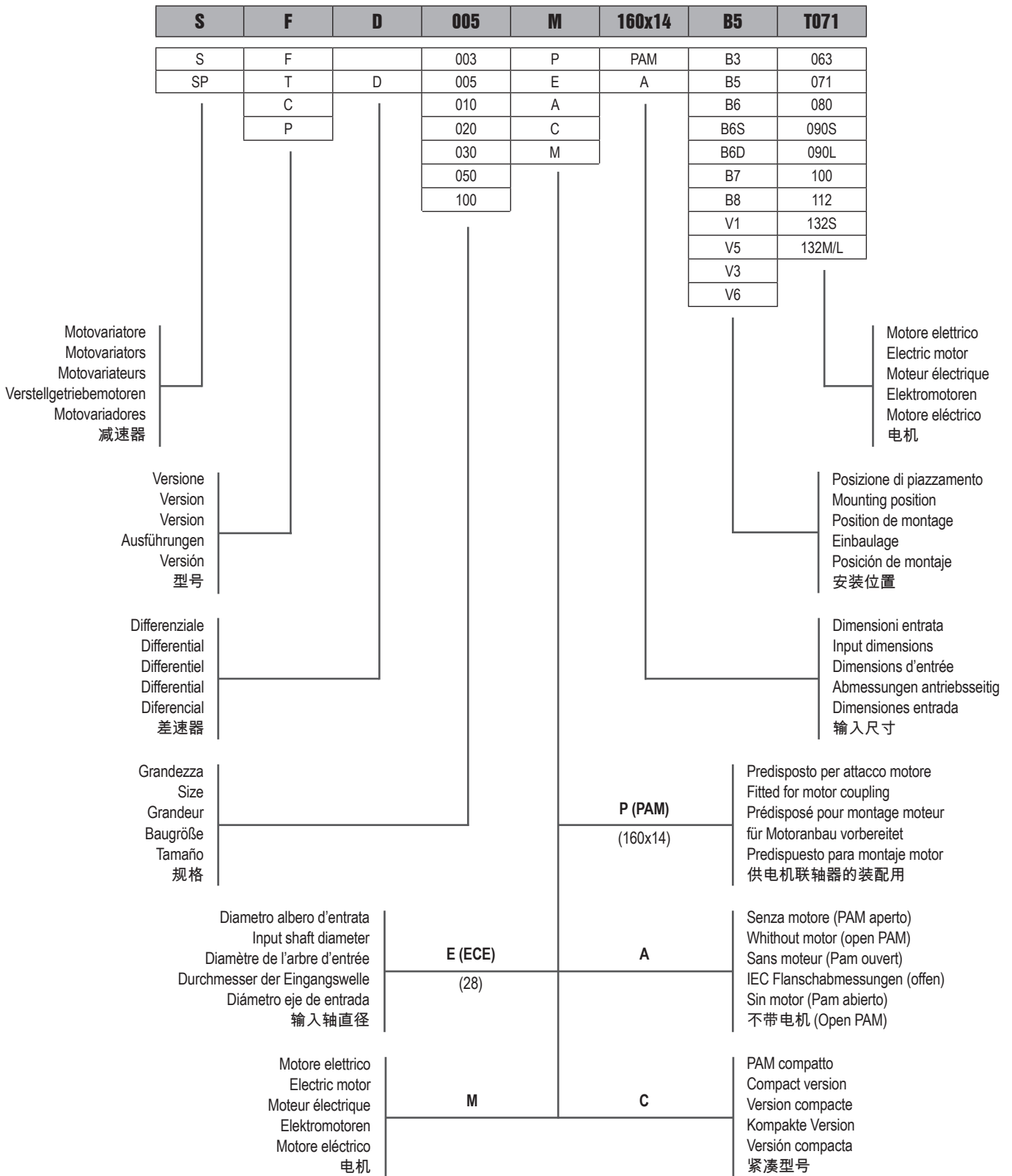

**Versioni / Versions / Versions /  
Ausführungen / Versiones / 版本**

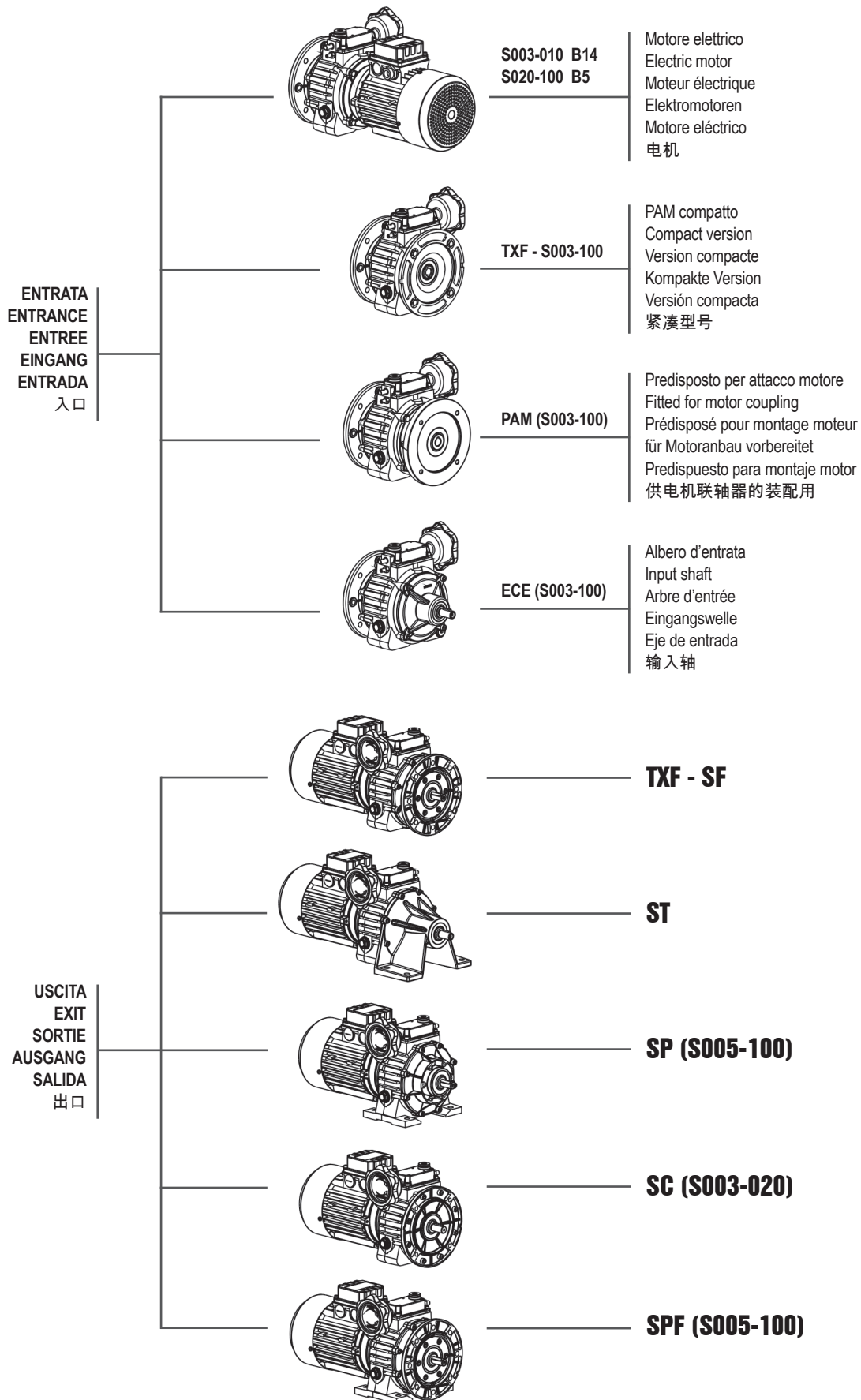

**TXF/S - Piazzamento / Mounting positions / Pos. de montage /  
Einbaulage / Pos. de montaje / 安装位置**

**TXF**

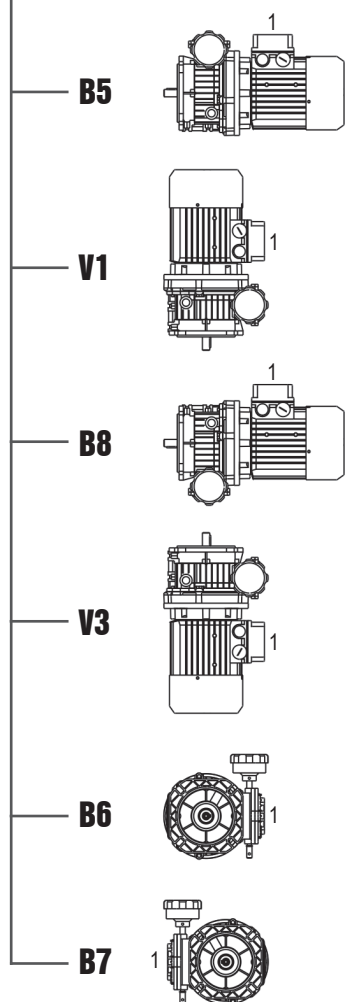

**SF**

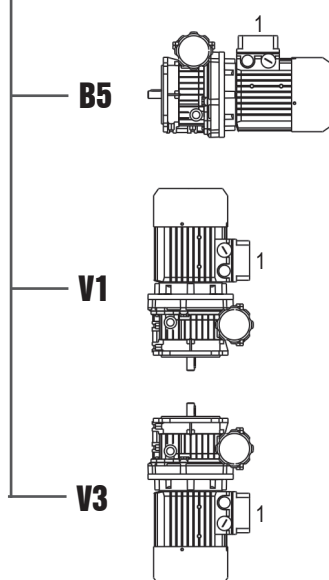

**ST**

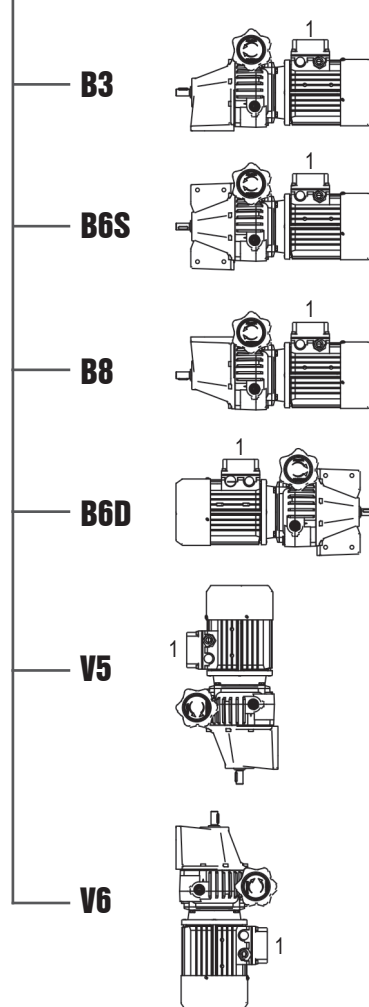

**Volantino di comando / Control handwheel /  
Volant de commande / Steuer-Handräd  
Volante de mando / 控制旋牛**

**Posizione morsettiera / Position of terminal box /  
Position du bornier / Klemmenkastenlage /  
Posición caja de bornes / 接线盒位置**

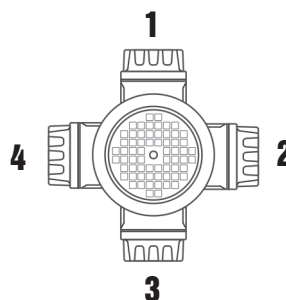
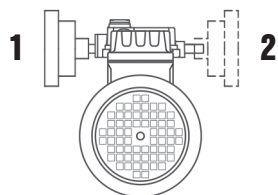

- Posizione morsettiera, se non diversamente specificato, il gruppo viene fornito con morsettiera in pos.1.
- Position of terminal box, unless otherwise specified, the gear reducer is supplied with terminal box in position 1.
- Position du bornier, sauf indications contraires, le réducteur est fourni avec boîte à borne en position 1.
- Klemmenkastenlage, Sofern nichts gegenteiliges angegeben, wird der Schneckengetriebemotor mit Klemmkastenlage 1 geliefert.
- Posición caja de bornes, si no está diferentemente especificado, el motorreductor se monta con la caja de bornes en posición 1.
- 接线盒位置，除非另有规定，齿轮变速器都配供有 1 号位接线盒。

## S - Prestazioni / Performance / Performances / Leistungen / Prestaciones / 性能

MOTOVARIATORI / MOTOVARIATOR / MOTOVARIATEUR /  
VERSTELLGETRIEBE / VARIADOR DE VELOCIDAD / 电机变速器

DIFFERENZIALE / DIFFERENTIAL / DIFFERENTIEL /  
DIFFERENTIAL / DIFERENCIAL / 差速器

P1 (kW)			n1 1/min	n2 (a) 1/min	n2 (b) 1/min	M2 (a) Nm	M2 (b) Nm	Fr2 (a) N	Fr2 (b) N		n2 max 1/min	n2 min 1/min	M2 max Nm
0,15	S003	63C6	900	620	125	2,1	4	500	700	-	-	-	-
0,22	S003	63C4	1400	950	190	2	4	440	760	-	-	-	-
0,25	S005	71A4	1400	950	190	2	6	802	1120	-	-	-	-
	S005	71B6	900	610	122	3	6	930	1120	SD005	610	0	6
0,37	S003	63C2	2800	1900	380	1,7	4	340	670	-	-	-	-
	S005	71B4	1400	950	190	3	6	810	1120	SD005	950	0	6
0,55	S005	71B2	2800	1900	380	2,2	6	640	1120	SD005	1900	0	6
	S005	71C4	1400	950	190	4,4	6	720	1120	SD005	950	0	6
	S010	80A4	1400	950	190	4,4	12	930	1910	-	-	-	-
	S010	80B6	900	610	122	6,6	12	1080	1910	SD010	610	0	12
0,75	S005	71C2	2800	1900	380	3	6	640	1120	SD005	1900	0	6
	S010	80B4	1400	950	190	6	12	940	1640	SD010	950	0	12
0,92	S010	80C4	1400	950	190	7,5	12	870	1640	SD010	950	0	12
1,10	S010	80B2	2800	1900	380	4,4	12	740	1300	SD010	1900	0	12
	S020	90S4	1400	1000	190	9	24	1130	1960	SD020	1000	0	24
	S020	90L6	900	660	122	13,5	24	1300	2290	SD020	660	0	24
1,50	S010	80C2	2800	1900	380	6	12	740	1300	SD010	1900	0	12
	S020	90S2	2800	2000	380	6	24	890	1560	SD020	2000	0	24
	S020	90L4	1400	1000	190	12	24	1130	1960	SD020	1000	0	24
	S030	100LA6	900	660	122	18	48	2570	4540	SD030	660	0	48
1,84	S020	90LL4	1400	1000	190	15	24	1050	1960	SD020	1000	0	24
2,20	S020	90L2	2800	2000	380	9	24	890	1560	SD020	2000	0	24
	S030	100LA4	1400	1000	190	18	48	2240	3890	SD030	1000	0	48
	S050	112M6	900	660	122	27	64	2570	4540	SD050	660	0	64
3,00	S030	100LB4	1400	1000	190	24	48	2240	3890	SD030	1000	0	48
4,00	S050	112M4	1400	1000	190	32	64	2240	3890	SD050	1000	0	64
4,80	S050	112MS4	1400	1000	190	40	64	2010	3890	SD050	1000	0	64
5,50	S100	132S4	1400	1000	190	44	144	2900	5050	SD100	1000	0	144
	S100	132M6	900	660	122	66	144	3330	5890	SD100	660	0	144
7,50	S100	132L4	1400	1000	190	60	144	2900	5050	SD100	1000	0	144
9,20	S100	132M4	1400	1000	190	74	144	2900	5050	SD100	1000	0	144

- (a) Valori relativi alla velocità max.  
(a) Values relating to maximum speed  
(a) Valeurs relatifs au vitesse maximum  
(a) Angaben im oberen Drehzahlbereich  
(a) Valores relativos a la velocidad máxima  
(a) 与最大速度有关的数值
- (b) Valori relativi alla velocità min.  
(b) Values relating to minium speed  
(b) Valeurs relatifs au vitesse minimum  
(b) Angaben im unteren Drehzahlbereich  
(b) Valores relativos a la velocidad mínima  
(b) 与最小速度有关的数值

**SF - Dimensioni / Dimensions / Encombremets /  
Abmessungen / Dimensiones / 尺寸**

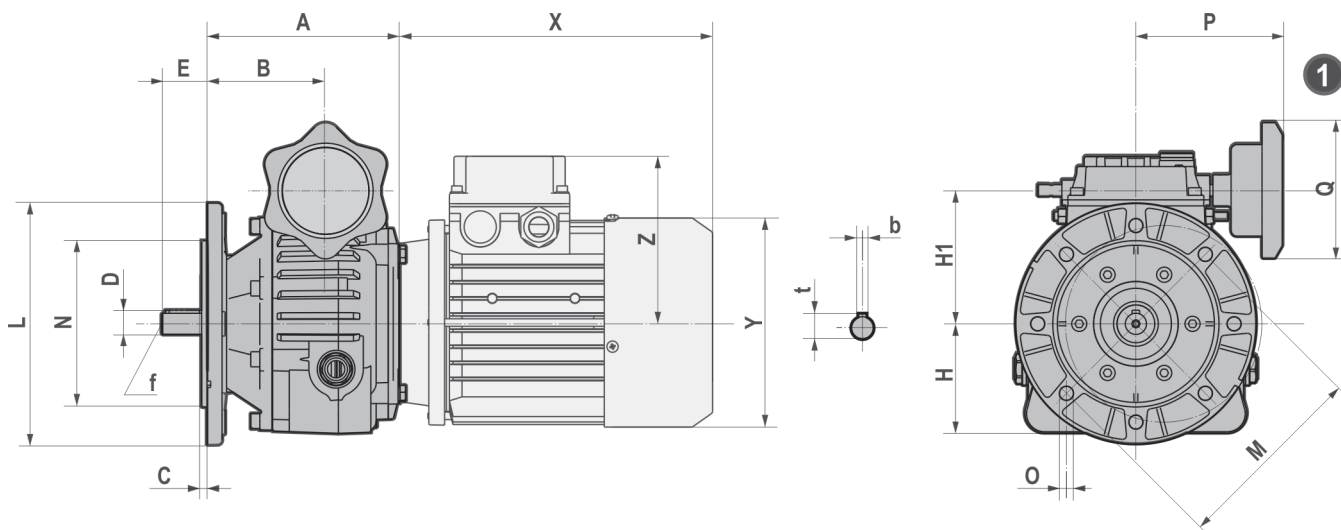

SF	A	B	C	D	E	H	H1	L	M	N
003	103	65.5	3	11 j6	23	58	75	140	115	95
			3.5	14 j6	30			160	130	110
005	127.5	78.5	3.5	14 j6	30	72.5	88	160	130	110
			3.5	19 j6	40			200	165	130
010	151	94.5	3.5	19 j6	40	90	107	160	130	110
			3.5	24 j6	50			200	165	130
020	173	105.5	3.5	24 j6	50	108	126	200	165	130
			4	28 j6	60			250	215	180
030/050	208	123.5	4	28 j6	60	134	158.5	250	215	180
			4	38 k6	80			300	265	230
100	266	164.5	4	38 k6	80	165	205.5	300	265	230
			5	42 k6	80			350	300	250

SF	O	P	Q	b	t	f	X	Y	Z	~Kg
003	9	97	90	4	12.5	M4	188	121	103.5	2.7
	9			5	16	M5				
005	9	97	90	5	16	M5	208.5	139	112	5.9
	11			6	21.5	M6				
010	9	107	90	6	21.5	M6	232.5	158	121.5	11.4
	11			8	27	M8				
020	11	117	90	8	27	M8	248	173	129.5	22.3
	14			8	31	M10	273			
030/050	14	154	120	8	31	M10	307.5	191	138.5	40.5
	14			10	41	M12	322.5			
100	14	184	120	10	41	M12	372.5	248.4	194	73
	18			12	45	M12	410.5			

## ST - Dimensioni / Dimensions / Encombresments / Abmessungen / Dimensiones / 尺寸

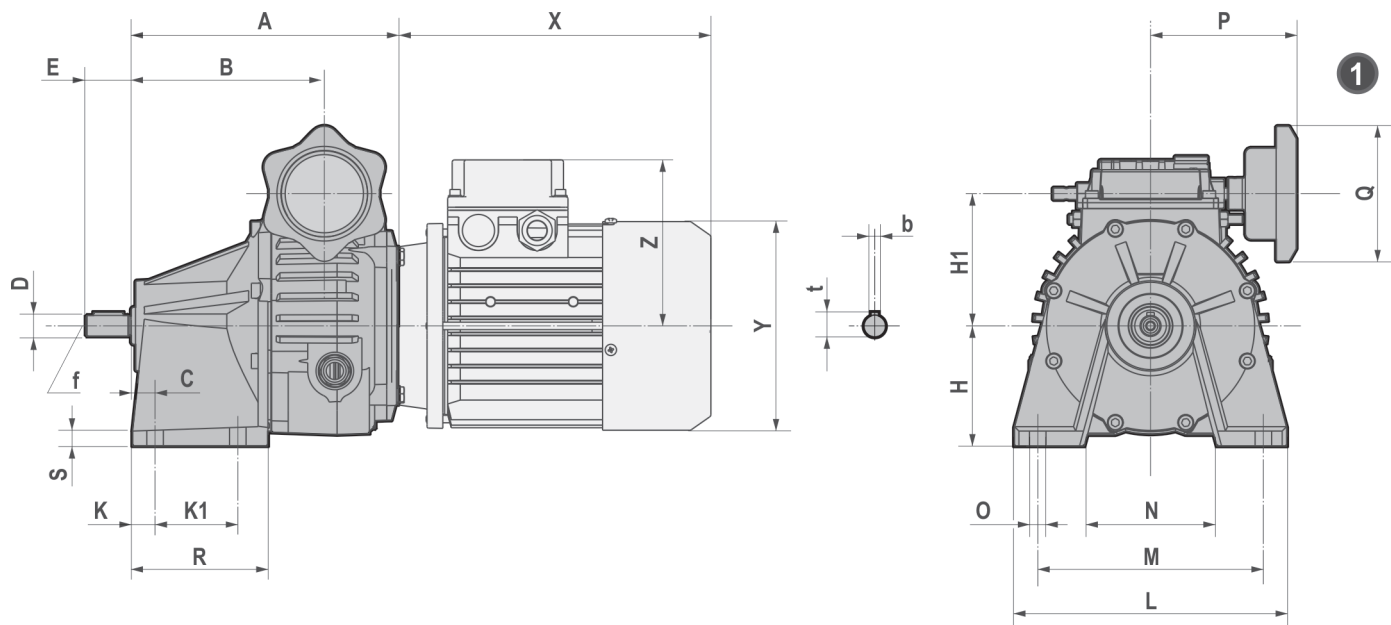

ST	A	B	C	D	E	H	H1	K	K1	L	M	N
003	131	93.5	16	11 j6	23	70	75	15	25	130	95	60
				14 j6	30							
005	177.5	128.5	16	14 j6	30	80	88	15	55	180	150	90
				19 j6	40							
010	213	156.5	19.5	19 j6	40	102	107	18.5	65	220	165	108
				24 j6	50							
020	251.5	184.5	25.5	24 j6	50	125	126	23.5	75	250	185	118
				28 j6	60							
030/050	294.5	210.5	27	38 k6	80	150	158.5	25	85	310	240	149
100	353.5	252.5	32	42 k6	80	190	205.5	29	120	384	295	193

ST	O	P	Q	R	S	b	t	f	X	Y	Z	~Kg
003	9	97	90	60	8	4	12.5	M4	188	121	103.5	3.0
						5	16	M6				
005	11	97	90	90	10	5	16	M6	208.5	139	112	8.7
						6	21.5	M6				
010	11	107	90	110	12	6	21.5	M6	232.5	158	121.5	16.1
						8	27	M8				
020	14	117	90	130	14	8	27	M8	248	173	129.5	27.3
						8	31	M8	273			
030/050	18	154	120	150	16	10	41	M10	307.5	191	138.5	41.5
									322.5			
100	20	184	120	186	20	12	45	M10	372.5	248.4	194	74.5
									410.5			



**SC - Dimensioni / Dimensions / Encombremets /  
Abmessungen / Dimensiones / 尺寸**

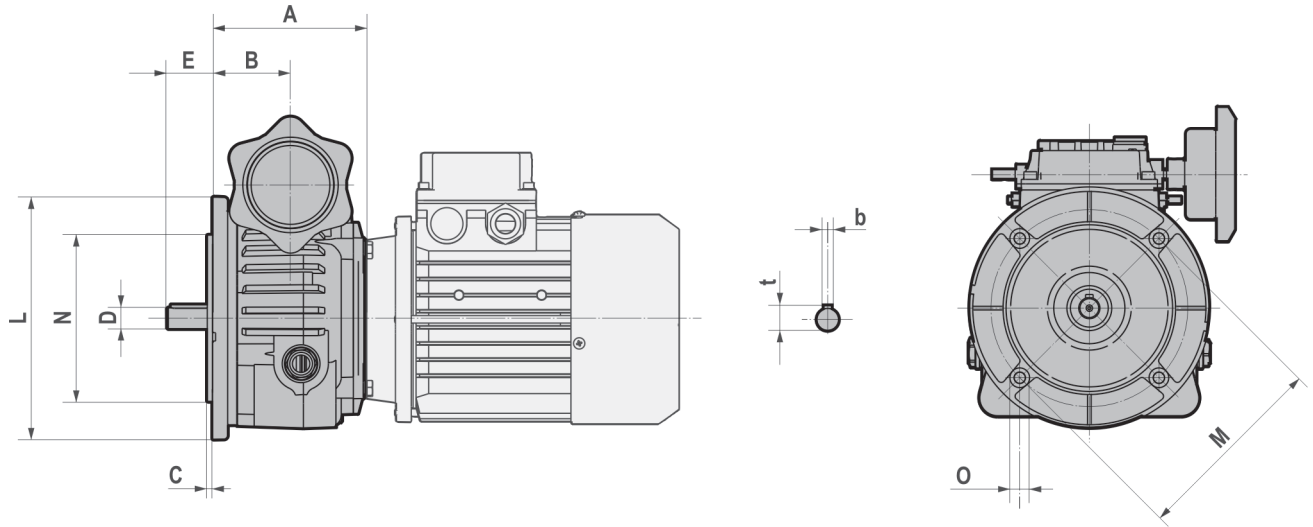

SC	A	B	C	D	E	L	M	N	O	b	t
003	79	41.5	3	11 j6	23	140	115	95	M6	4	12.5
				14 j6	30					5	16
005	100.5	51.5	3.5	14 j6	30	160	130	110	M8	5	16
				19 j6	40					6	21.5
010	117	60.5	3.5	19 j6	40	200	165	130	M10	6	21.5
				24 j6	50					8	27
020	135.5	68.5	3.5	24 j6	50	200	165	130	M10	8	27
				28 j6	60					8	31

**SP - Dimensioni / Dimensions / Encombremets /  
Abmessungen / Dimensiones / 尺寸**

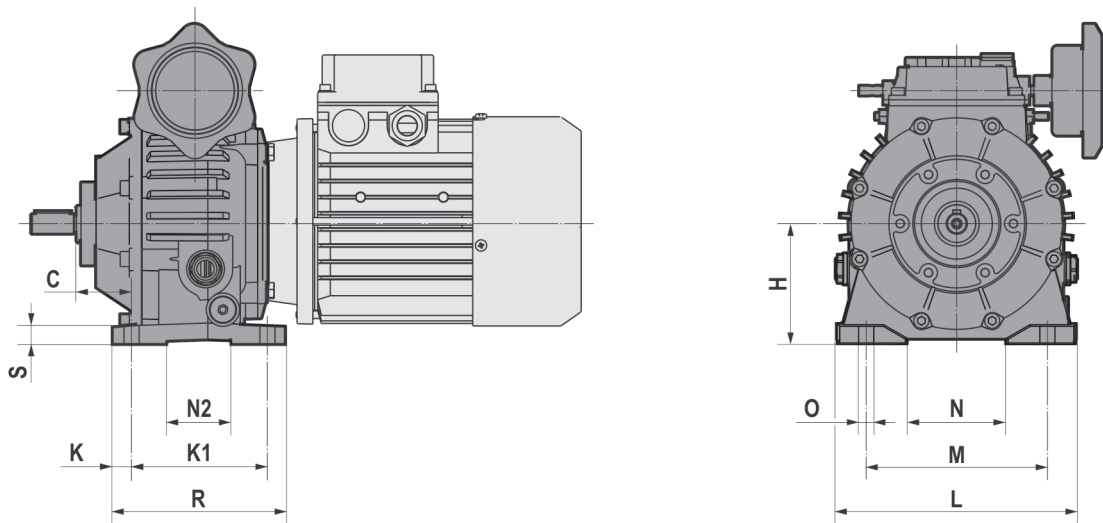

SP	C	H	K	K1	L	M	N	N2	O	R	S
005	36.5	80	12.5	90	155	120	42	65	10	115	12
010	42.5	102	12.5	110	200	150	86	75	11	135	13
020	55.5	125	12.5	115	235	205	103	90	11	140	16
030/050	25.5	150	15	220	290	255	118	140	14	250	20
100	55.5	180	25	255	365	320	140	175	18	305	25

**PAM - Dimensioni / Dimensions / Encombremets /  
Abmessungen / Dimensiones / 尺寸**

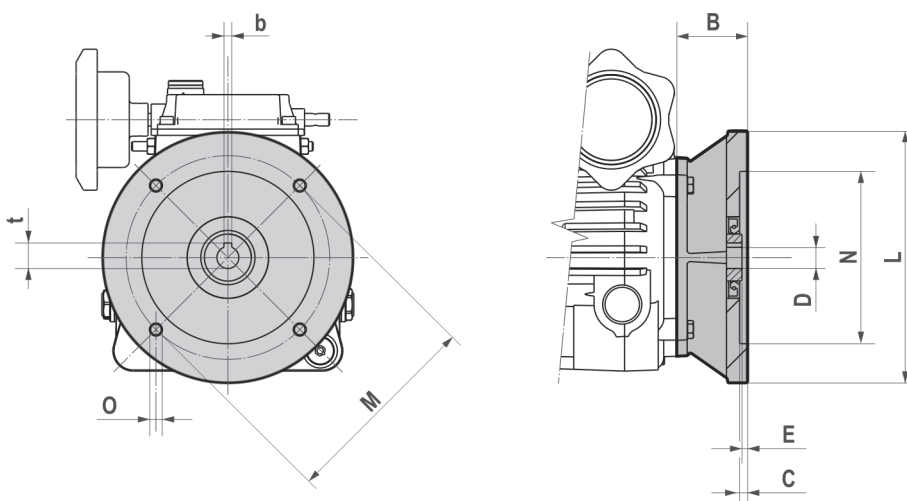

S	B	C	D	E	L	M	N	O	b	t
003	50	4	14	2	105	85	70	6.5	5	16.3
			11		140	115	95	M8	4	12.8
005	45	4	19	3	120	100	80	6.5	6	21.8
		4.5	14		160	130	110	M8	5	16.3
		4.5	19		200	165	130	M10	6	21.8
010	62	5	19	3.25	200	165	130	M10	6	21.8
			24						8	27.3
020	63	4.5	24	1.9	200	165	130	M10	8	27.3
	73	5	28		250	215	180	M12	8	31.3
030/050	72.5	5	28	2	250	215	180	M12	8	31.3
	87.5		38		300	265	230		10	41.3
100	95	5.5	38	5	300	265	230	13.5	10	41.3
	125	6	42	25	350	300	250	M16	12	45.3

**ECE - Dimensioni / Dimensions / Encombremets /  
Abmessungen / Dimensiones / 尺寸**

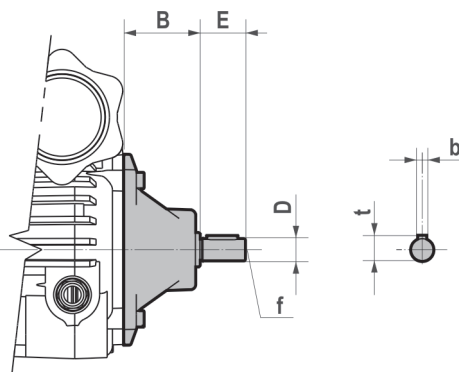

S	B	D	E	f	b	t
003	50	11	23	M4	4	12.5
005	50	14	30	M6	5	16
010	65	19	40	M6	6	21.5
020	70	24	50	M8	8	27
030/050	94.5	28	60	M8	8	31
100	110	38	80	M10	10	41

**SD - Dimensioni / Dimensions / Encombremets /  
Abmessungen / Dimensiones / 尺寸**

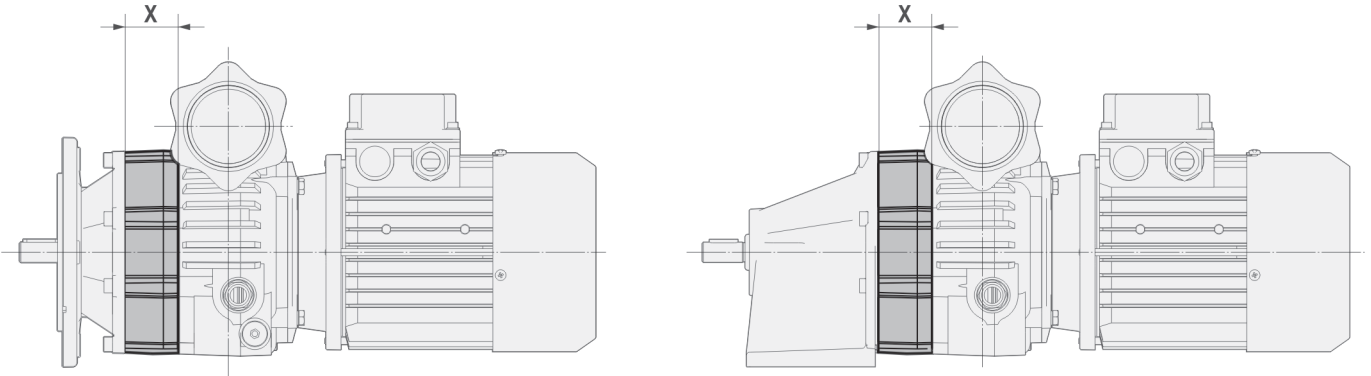

S	005	010	020	030/050	100
X	37.5	33.5	37	54	54

X - Quota di maggiorazione valida per tutte le versioni  
 X - Allowance value valid for all versions  
 X - Majoration de cote valide pour toutes les versions  
 X - Abmessungen sind für alle Versionen gültig  
 X - Cuota de incremeto valida para todas las versiones  
 X - 公差值对所有版本都有效。

**PAM C - Dimensioni / Dimensions / Encombremets /  
Abmessungen / Dimensiones / 尺寸**

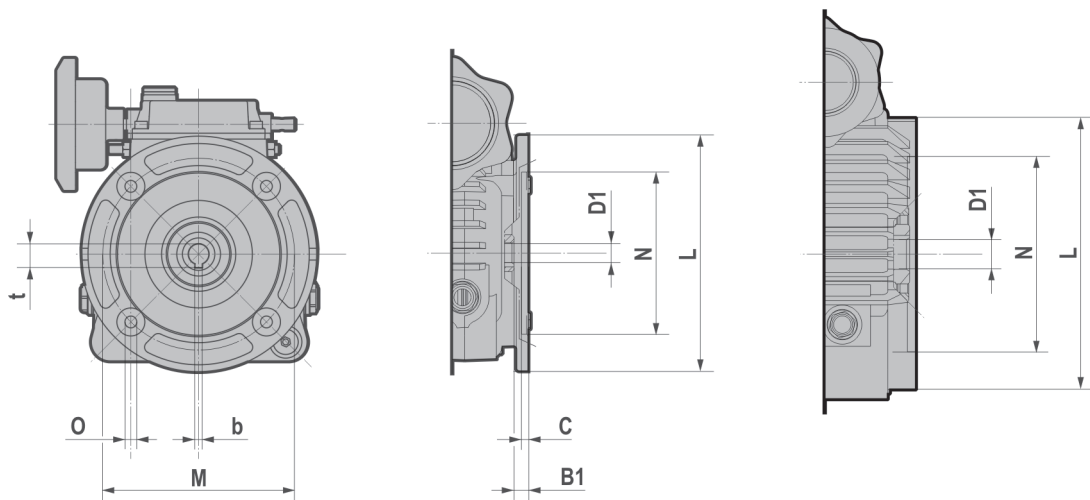

S	B1	C	D1	L	M	N	O	b	t
003	17.5	4	11	140	115	95	M8	4	12.8
005	10	4	14	160	130	110	M8	5	16.3
010	11	5	19	200	165	130	M10	6	21.8
020	/	/	24	200	165	130	M10	8	27.3
030/050	/	/	28	250	215	180	M12	8	31.3
100	/	/	38	300	265	230	M12	10	41.3

**Motori elettrici / Electric motors / Moteurs électriques /  
Elektromotoren / Motores electricos / 电机**

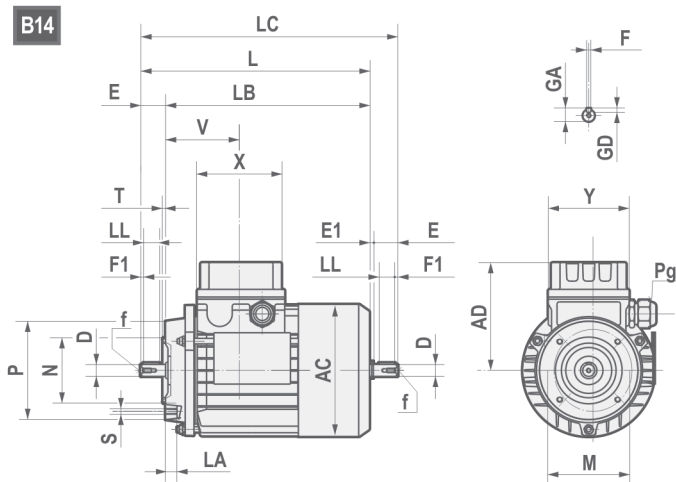
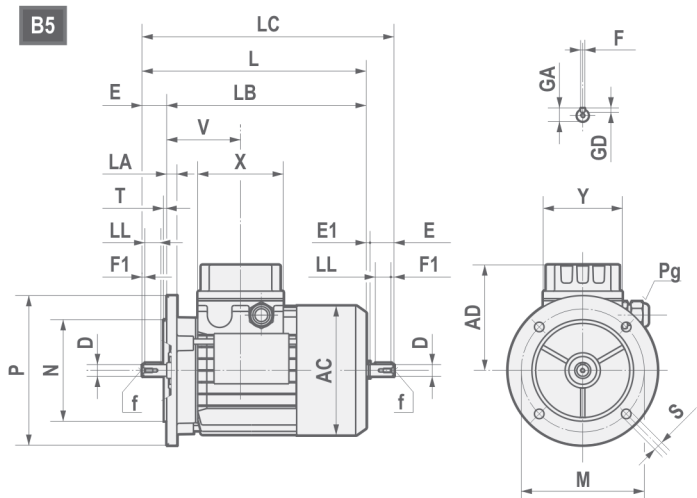

	AC	AD	L	LB	LC	X	Y	V	D	E	E1	f	F1	GA	F	GD	LL	Pg		
																		ø min	ø max	
<b>63</b>	121	103,5	211	188	235,5	80	74	69	11 j6	23	1,5	M4x10	2,5	12,5	4	4	15	M16x1,5	5	10
<b>71</b>	139	112,5	238,5	208,5	271	80	74	74,5	14 j6	30	2,5	M5x12,5	3	16	5	5	20	M20x1,5	6	12
<b>80</b>	158	121,5	272,5	232,5	314	80	74	78	19 j6	40	1,5	M6x16	5	21,5	6	6	30	M20x1,5	6	12
<b>90S</b>	173	129,5	298	248	349,5	98	98	89,5	24 j6	50	1,5	M8x19	5	27	8	7	35	M25x1,5	9	17
<b>90L</b>	173	129,5	323	273	374,5	98	98	89,5	24 j6	50	1,5	M8x19	5	27	8	7	35	M25x1,5	9	17
<b>100</b>	191	138,5	368	308	431,5	98	98	97,5	28 j6	60	2,5	M10x22	7,5	31	8	7	45	M25x1,5	9	17
<b>112</b>	210,5	153,5	382,5	323,5	447	98	98	100	28 j6	60	1,5	M10x22	7,5	31	8	7	45	M25x1,5	9	17
<b>132S</b>	248,4	177,5	452	372	536,5	118	118	115,5	38 k6	80	4	M12x28	10	41	10	8	60	M32x1,5	11	21
<b>132M/L</b>	248,4	177,5	490	410	574,5	118	118	115,5	38 k6	80	4	M12x28	10	41	10	8	60	M32x1,5	11	21

B5	M	N	P	LA	S	T
<b>63</b>	115	95 j6	140	9,5	9	3
<b>71</b>	130	110 j6	160	10	9,5	3,5
<b>80</b>	165	130 j6	200	12	11	3,5
<b>90</b>	165	130 j6	200	12	11	3,5
<b>100</b>	215	180 j6	250	15	14	4
<b>112</b>	215	180 j6	250	14,5	14	4
<b>132</b>	265	230 j6	300	20	14	3,5

B14	M	N	P	LA	S	T
<b>63</b>	75	60 j6	90	10,5	M5	2,5
<b>71</b>	85	70 j6	105	10,5	M6	2,5
<b>80</b>	100	80 j6	120	10,5	M6	3
<b>90</b>	115	95 j6	140	11,5	M8	3
<b>100</b>	130	110 j6	160	15	M8	3,5
<b>112</b>	130	110 j6	160	11,5	M8	3,5
<b>132</b>	165	130 j6	200	20,5	M10	3,5

**Potenza nominale (kW) / Nominal power (kW) / Puissance nominale (kW) /  
Nennleistung (kW) / Potencial nominal (kW) / 标称功率 (kW)**

	63A	63B	63C	71A	71B	71C	80A	80B	80C	90S
<b>2(*)</b>	0,18	0,25	0,37	0,37	0,55	0,75	0,75	1,1	1,5	1,5
<b>4(*)</b>	0,12	0,18	0,22	0,25	0,37	0,55	0,55	0,75	0,92	1,1
<b>6(*)</b>	0,09	0,12	0,15	0,18	0,25	0,37	0,37	0,55	0,75	0,75
<b>8(*)</b>			0,07	0,09	0,12	0,18	0,18	0,25	0,37	0,37
	90L	90LL	100LA	100LB	112M	112MS	132SA	132SB	132L	132M
<b>2(*)</b>	2,2		3	4	4	5,5	5,5	7,5	9,2	11
<b>4(*)</b>	1,5	1,84	2,2	3	4	4,8	5,5		7,5	9,2
<b>6(*)</b>	1,1		1,5	1,85	2,2	3	3		4	5,5
<b>8(*)</b>	0,55		0,75	1,1	1,5		2,2		3	

(\*) Poli / Poles / Pôles / Pole / Polos / 极性

**Servocomando elettrico / Electrical servocontrol / Servocommande électrique / Elektrische Servosteuerung / Servocomando electrico / 电气狼心肠控制**

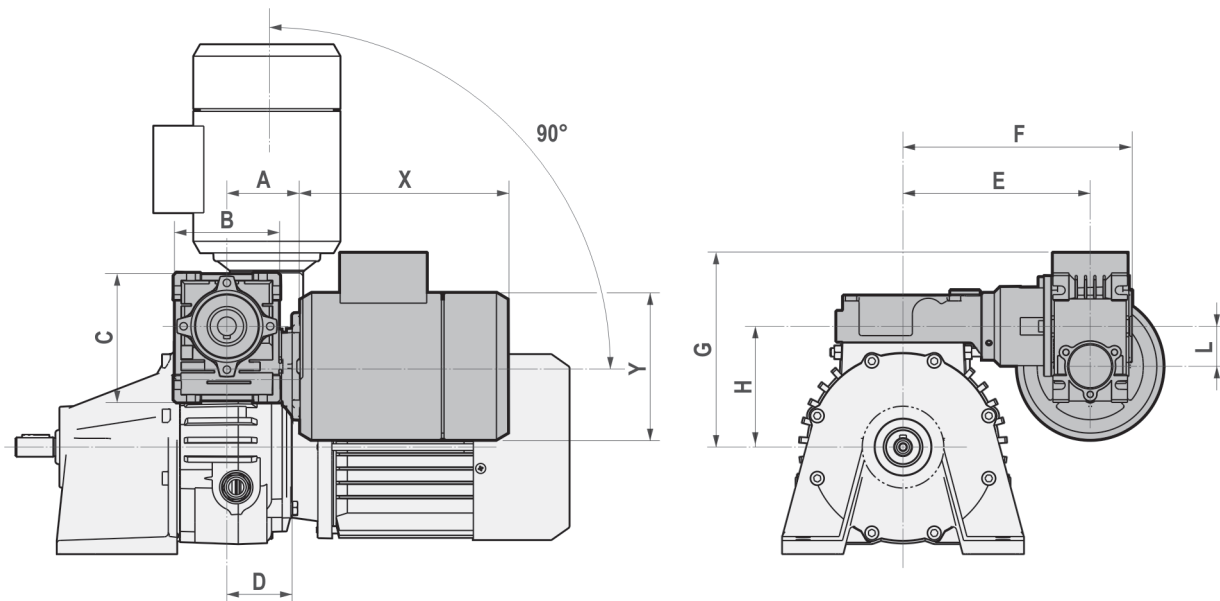

S	A	B	C	D	E	F	G	H	L	X	Y
005	55	80	97	49	140.5	172	130.5	90.5	30	169	110
010	55	80	97	56.5	150.5	182	148.5	108.5	30	169	110
020	55	80	97	67.5	160.5	192	167.5	127.5	30	169	110
030/050	55	80	97	84.5	164	195.5	198.5	158.5	30	169	110
100	55	80	97	102	204	235.5	245.5	205.5	30	188	121

TXF002-005-010  
 S005-010-020-030/050  
 P1 = 0.09 kW/4 - i=30

S100  
 P1 = 0.18 kW/4 - i=30

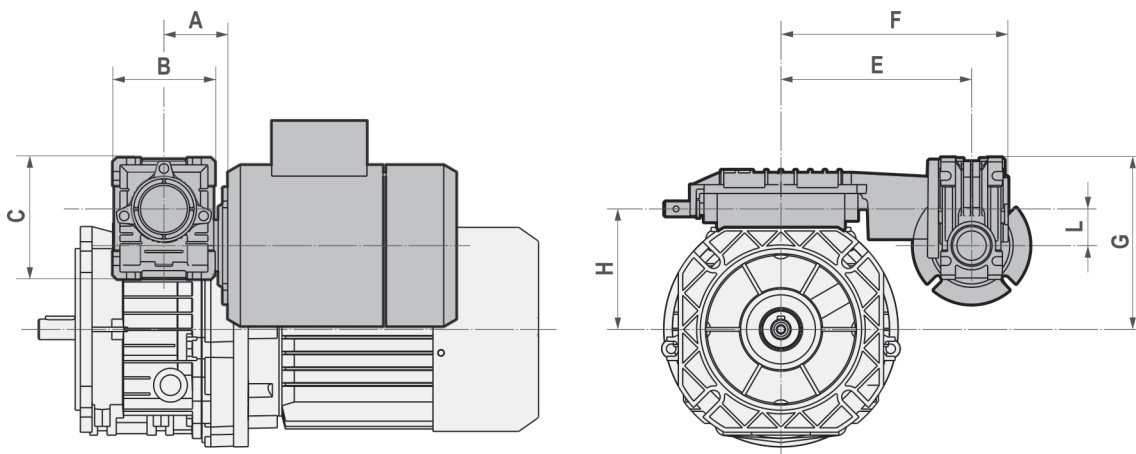

TXF	A	B	C	E	F	G	H	L
002	45	70	83	130	155	104	69	25
005	45	70	83	130	155	117	82	25
010	45	70	83	140	165	138	103	25

- Il motore pilota deve essere alimentato dal motore principale in quanto la regolazione dei giri deve avvenire a motore principale in moto.
- The servomotor must be linked to the main variator drive motor since the speed setting must only be varied while the motovariator is running.
- Le moteur pilote doit être alimenté à partir du moteur principal car la variation des tours doit se faire moteur principal en marche.
- Aufgrund der nur bei laufendem Motor freigegebenen Drehzahlverstellung ist der Steuermotor durch den Hauptmotor zu versorgen.
- El motor del servocomando debe ser alimentado por el motor principal dado que la regulación debe ser efectuada con el motor principal en movimiento.
- 伺服电机连接至主电机，因为设定速度只能在 电机变速器运行时才可以变化。

Servocomando elettrico / Electrical servocontrol / Servocommande électrique / Elektrische Servosteuerung / Servocomando electrico / 电气狼心肠控制

POS.1

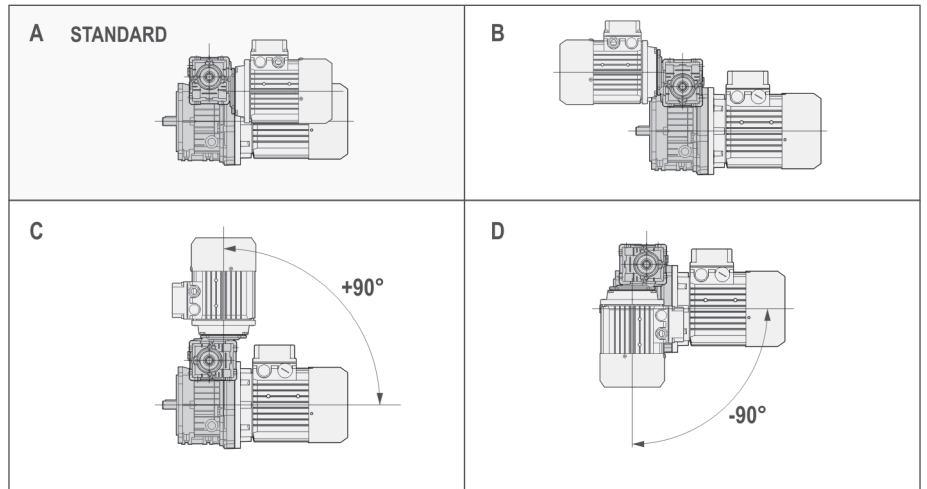
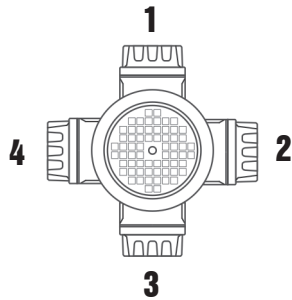

POS.2

- Posizione morsetteria, se non diversamente specificato, il gruppo viene fornito con morsetteria in pos.1.
- Position of terminal box, unless otherwise specified, the gear reducer is supplied with terminal box in position 1.
- Position du bornier, sauf indications contraires, le réducteur est fourni avec boîte à borne en position 1.
- Klemmenkastenlage. Sofern nichts Gegenteiliges angegeben, wird der Schneckengetriebemotor mit Klemmkastenlage 1 geliefert.
- Posición caja de bornes, si no está diferentemente especificado, el motorreductor se monta con la caja de bornes en posición 1.
- 接线盒位置, 除非另有规定, 齿轮变速器都配供有 1 号位接线盒。

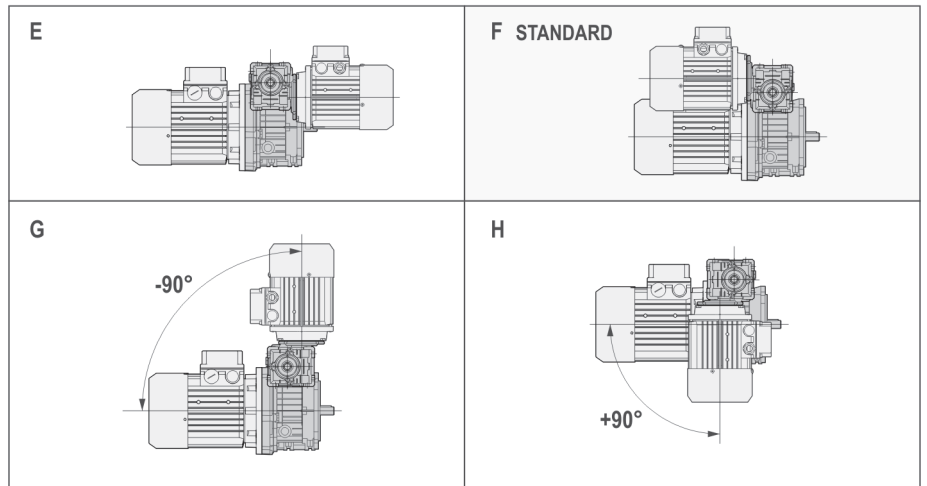

	TXF							
	A	B	C	D	E	F	G	H
TXF002-063								
TXF005-071								
TXF005-080								
TXF010-080								
TXF010-090								

	SF-ST							
	A	B	C	D	E	F	G	H
S005-071								
S005-PAM120-160								
S005-PAM200								
S010-080/090								
S010-PAM200								
S020-090								
S020-PAM200-250								
S030/050-100-112								
S030/050-PAM250-300								
S100-132								
S100-PAM300-350								

- Piazzamento possibile  
 - Available position  
 - Position de montage disponible  
 - Mögliche Einbaulage  
 - Posición de montaje posible  
 - 不应许的安装位子

- Piazzamento non possibile  
 - Not available position  
 - Position de montage pas disponible  
 - Einbaulage nicht möglich  
 - Posición de montaje no posible  
 - 应许的安装位子