

VRT SERIES

The VRT series sets the new standard in applications requiring extremely high torque density and rigidity. Its compact design and robotic industry ISO flange is ideal for equipment requiring high speed, high precision indexing movement and streamlined installation. The remarkable torsional stiffness and ultra low backlash combine to provide outstanding positioning accuracy.

This product comes standard with <3 arc-min backlash, but is also available with reduced options down to <1 arc-min. The VRT is the most robust planetary solution in the marketplace and is used across a numerous range of applications including 7th axis robot shuttles, dial tables, end of arm tooling and any other axis where installation space, reduced assembly time and torque density play an important role.

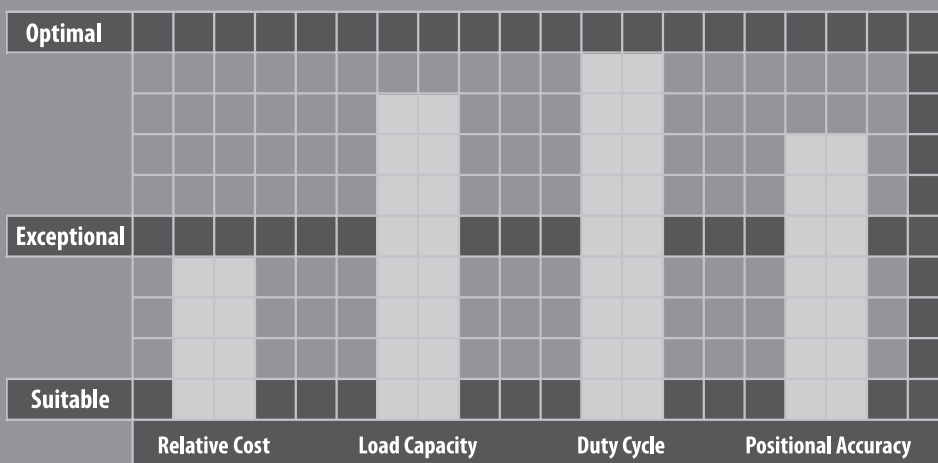

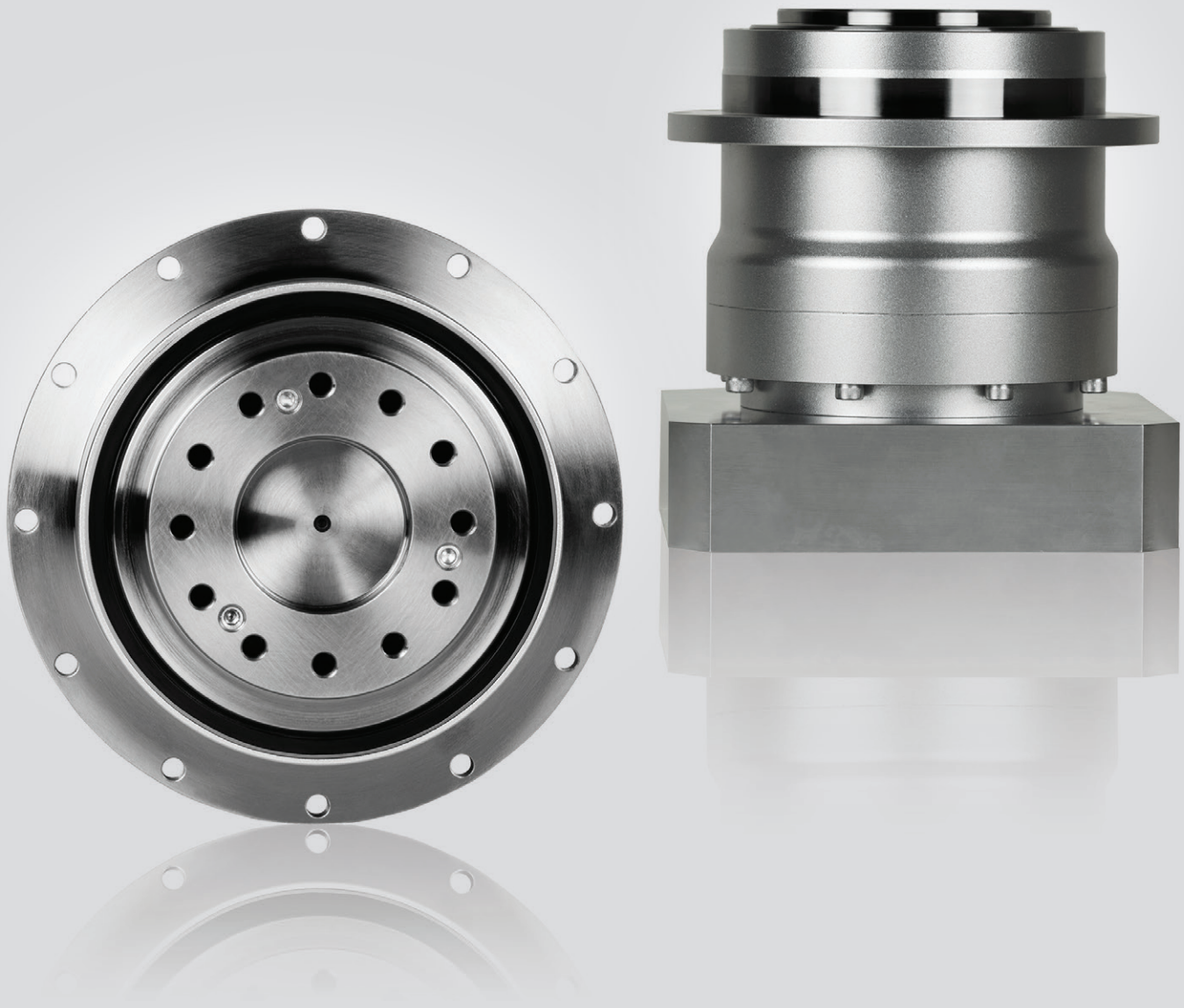

VRT SERIES

- The most compact and robust option for machine builders. Tapered roller bearings allow for high radial and axial loading
- ISO robotic mounting interface for superior flexibility and direct mounting of pinions, pulleys and turntables
- Exceptional torsional rigidity for high positional accuracy needs
- Best-In-class standard backlash (≤ 3 arc-min) with reduced backlash options available
- Broad range of mounting adapters offer a simple, precise attachment to any motor
- Maintenance-free solution that is lubricated for life. High performance grease allows flexible mounting in any orientation

VRT SERIES Inline Planetary

VRT Series Features

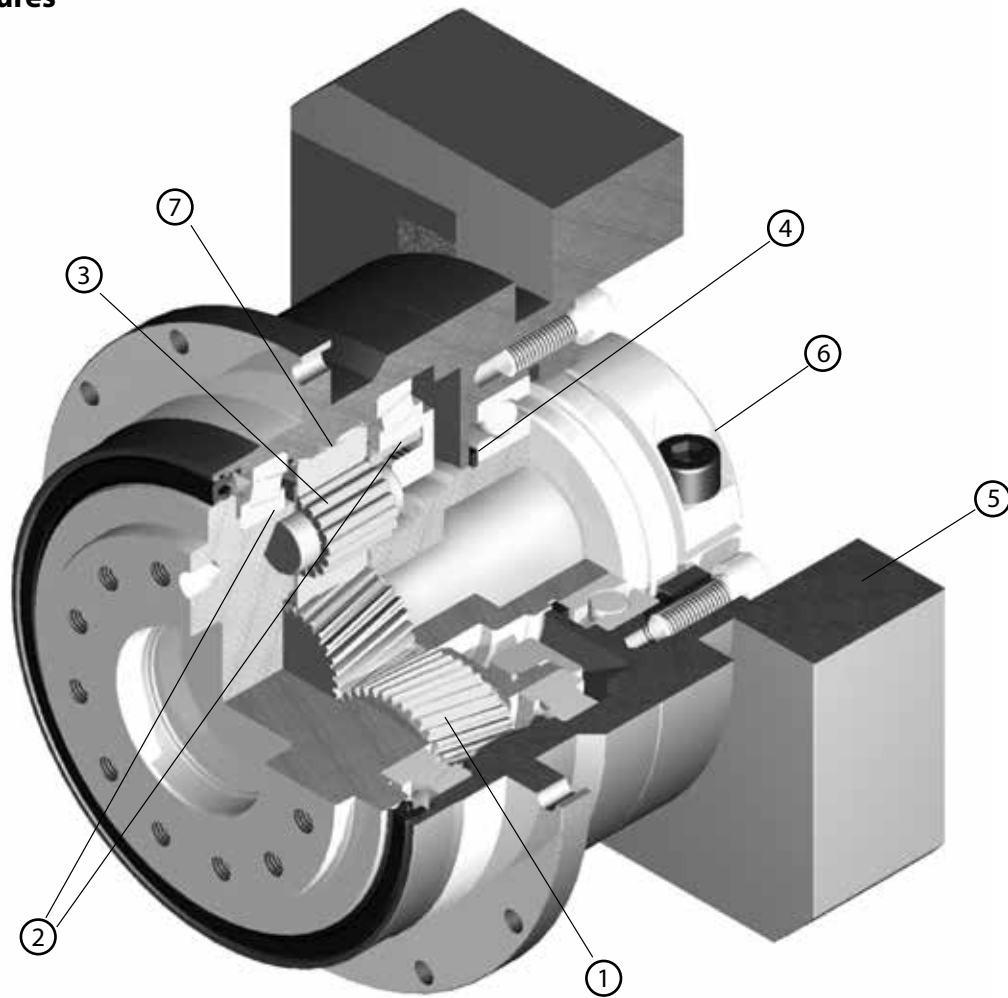

- ① Carburized, case hardened helical gears with proprietary secondary finishing process for higher accuracy and smooth, quiet operation
- ② One piece output shaft and planet carrier with two robust tapered bearings straddling the planet gears. Higher radial/axial load capacity, stiffness, torque density and safety factor, with guaranteed alignment of gearing
- ③ Uncaged needle roller bearings provide excellent torque density and torsional rigidity
- ④ Unique labyrinth input seal design greatly reduces heat and increases system efficiency. IP65 protection is available for wash down applications
- ⑤ Optimized mounting system with active centering on motor pilot diameter guarantees alignment of motor. Motor can be installed in any orientation
- ⑥ True concentric motor shaft clamping connection, optimized for your specific motor. Reduced inertia for dynamic performance and balanced for high speed operation
- ⑦ Ring gear machined directly into the housing, not welded or pressed in. Provides greater concentricity and elimination of speed fluctuation

VRT Series Model Code

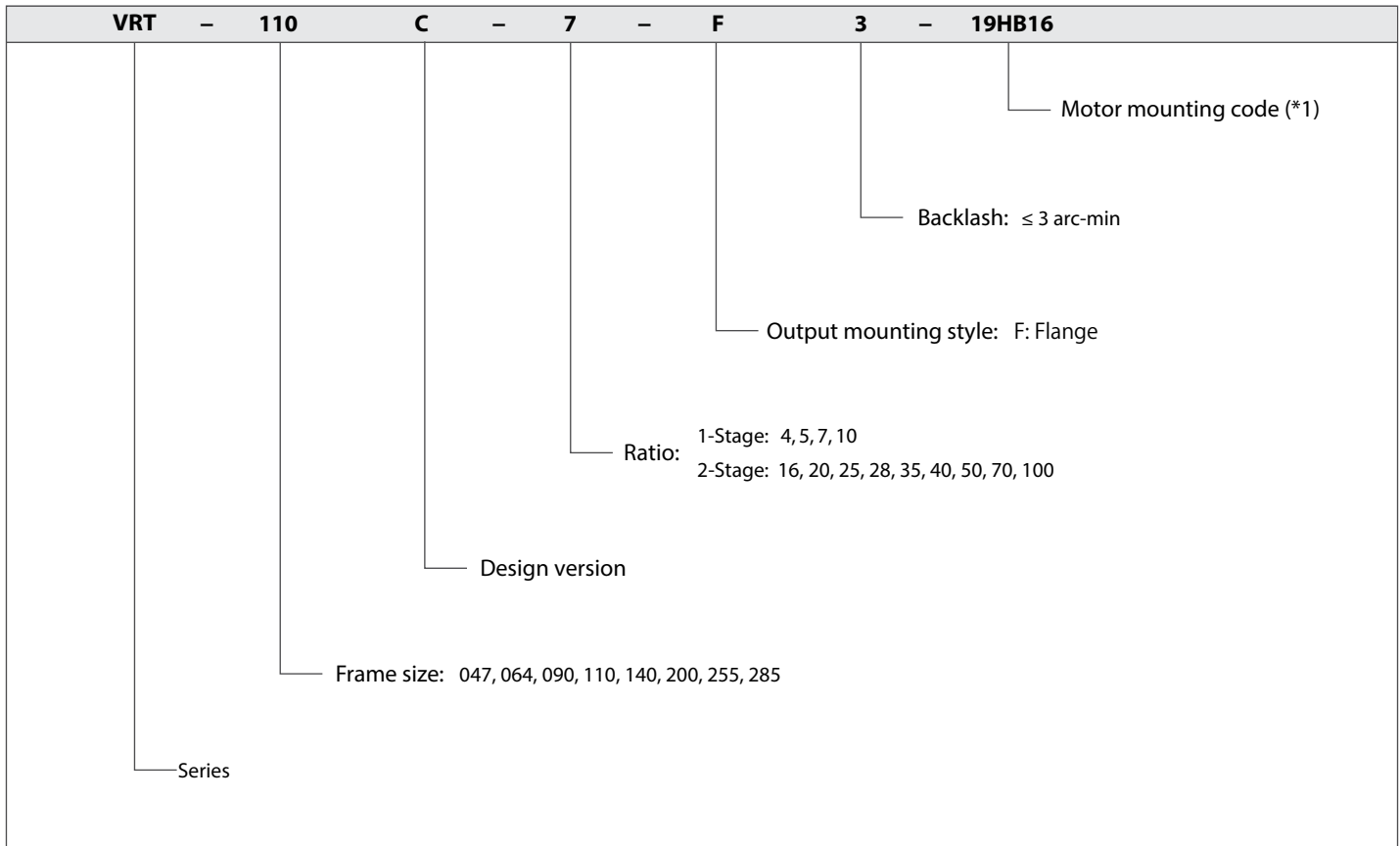

VRT

*1) Motor mounting code varies depending on the motor. Use the selection tool link below to configure the code.

Contact us for additional information or refer to our online gearbox selection tool.
 Selection tool www.nidec-shimpo.co.jp/selection/eng

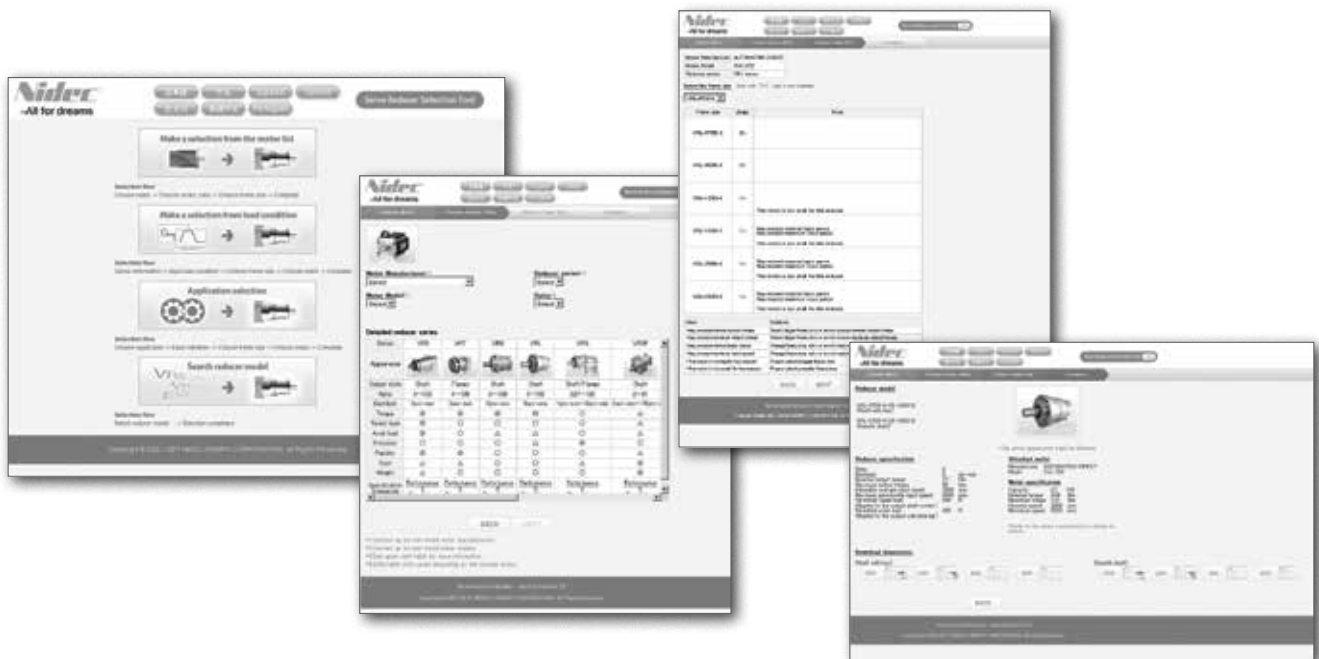

VRT SERIES Inline Planetary

VRT 047 1-Stage Specifications

Frame Size	047										
Ratio	Unit	Notes	4	5	6	7	8	9	10		
Nominal Output Torque	[Nm]	*1	9	9	9	9	9	6	6		
Maximum Acceleration Torque	[Nm]	*2	18	18	18	18	18	12	12		
Emergency Stop Torque	[Nm]	*3	35	35	35	35	35	30	30		
Nominal Input Speed	[rpm]	*4	4000								
Maximum Input Speed	[rpm]	*5	8000								
No Load Running Torque	[Nm]	*6	0.03								
Permitted Radial Load	[N]	*7	270	300	310	330	350	360	370		
Permitted Axial Load	[N]	*8	300	330	360	390	410	430	450		
Maximum Radial Load	[N]	*9	1100								
Maximum Axial Load	[N]	*10	550								
Maximum Tilting Moment	[Nm]	*11	32								
Moment of Inertia ($\leq \varnothing 8$)	[kgcm ²]	--	0.052	0.043	0.038	0.036	0.034	0.033	0.032		
Moment of Inertia ($\leq \varnothing 14$)	[kgcm ²]	--	0.17	0.16	0.15	0.15	0.15	0.15	0.15		
Efficiency	[%]	*12	95								
Torsional Rigidity	[Nm/arc-min]	*13	2								
Maximum Torsional Backlash	[arc-min]	--	≤ 3								
Noise Level	dB [A]	*14	≤ 61								
Protection Class	--	*15	IP54 (IP65)								
Ambient Temperature	[°C]	--	0 - 40								
Permitted Housing Temperature	[°C]	--	90								
Weight	[kg]	*16	0.7								

VRT 047 2-Stage Specifications

Frame Size	047										
Ratio	Unit	Notes	16	20	25	28	35	40	45		
Nominal Output Torque	[Nm]	*1	9	9	9	9	9	9	6		
Maximum Acceleration Torque	[Nm]	*2	18	18	18	18	18	18	12		
Emergency Stop Torque	[Nm]	*3	35	35	35	35	35	35	30		
Nominal Input Speed	[rpm]	*4	4000								
Maximum Input Speed	[rpm]	*5	8000								
No Load Running Torque	[Nm]	*6	0.01								
Permitted Radial Load	[N]	*7	440	470	510	530	570	590	620		
Permitted Axial Load	[N]	*8	550	550	550	550	550	550	550		
Maximum Radial Load	[N]	*9	1100								
Maximum Axial Load	[N]	*10	550								
Maximum Tilting Moment	[Nm]	*11	32								
Moment of Inertia ($\leq \varnothing 8$)	[kgcm ²]	--	0.039	0.035	0.034	0.038	0.034	0.030	0.034		
Efficiency	[%]	*12	90								
Torsional Rigidity	[Nm/arc-min]	*13	2								
Maximum Torsional Backlash	[arc-min]	--	≤ 5								
Noise Level	dB [A]	*14	≤ 61								
Protection Class	--	*15	IP54 (IP65)								
Ambient Temperature	[°C]	--	0 - 40								
Permitted Housing Temperature	[°C]	--	90								
Weight	[kg]	*16	0.8								

VRT 047 2-Stage Specifications

Frame Size	047							
Ratio	Unit	Notes	50	60	70	80	90	100
Nominal Output Torque	[Nm]	*1	9	9	9	9	6	6
Maximum Acceleration Torque	[Nm]	*2	18	18	18	18	12	12
Emergency Stop Torque	[Nm]	*3	35	35	35	35	30	30
Nominal Input Speed	[rpm]	*4	4000					
Maximum Input Speed	[rpm]	*5	8000					
No Load Running Torque	[Nm]	*6	0.01					
Permitted Radial Load	[N]	*7	640	680	710	750	780	800
Permitted Axial Load	[N]	*8	550	550	550	550	550	550
Maximum Radial Load	[N]	*9	1100					
Maximum Axial Load	[N]	*10	550					
Maximum Tilting Moment	[Nm]	*11	32					
Moment of Inertia ($\leq \varnothing 8$)	[kgcm ²]	--	0.030	0.030	0.030	0.030	0.030	0.030
Efficiency	[%]	*12	90					
Torsional Rigidity	[Nm/arc-min]	*13	2					
Maximum Torsional Backlash	[arc-min]	--	≤ 5					
Noise Level	dB [A]	*14	≤ 61					
Protection Class	--	*15	IP54 (IP65)					
Ambient Temperature	[°C]	--	0 - 40					
Permitted Housing Temperature	[°C]	--	90					
Weight	[kg]	*16	0.8					

- *1) At nominal input speed, service life is 20,000 hours
- *2) The maximum torque when starting or stopping operation
- *3) The maximum torque allowed under a stress situation (Permitted 1,000 times during service life)
- *4) The average input speed
- *5) The maximum intermittent input speed
- *6) Torque at no load applied to the input shaft at nominal input speed
- *7) At this load and nominal input speed, service life will be 20,000 hours. (The radial load applied to the output side shaft center)
- *8) At this load and nominal input speed, service life will be 20,000 hours. (The axial load applied to the output side bearing)
- *9) The maximum radial load that the gearbox can accept
- *10) The maximum axial load that the gearbox can accept
- *11) The moment is the maximum load at output flange surface
- *12) The efficiency at the nominal output torque rating
- *13) This does not include lost motion
- *14) Contact NIDEC-SHIMPO for the testing conditions and environment
- *15) IP65 (wash-down) is available as an option. Contact NIDEC-SHIMPO for more details
- *16) The weight may vary slightly between models

VRT SERIES Inline Planetary

VRT 047 1-Stage Dimensions

Input bore size $\leq \varnothing 8$ mm

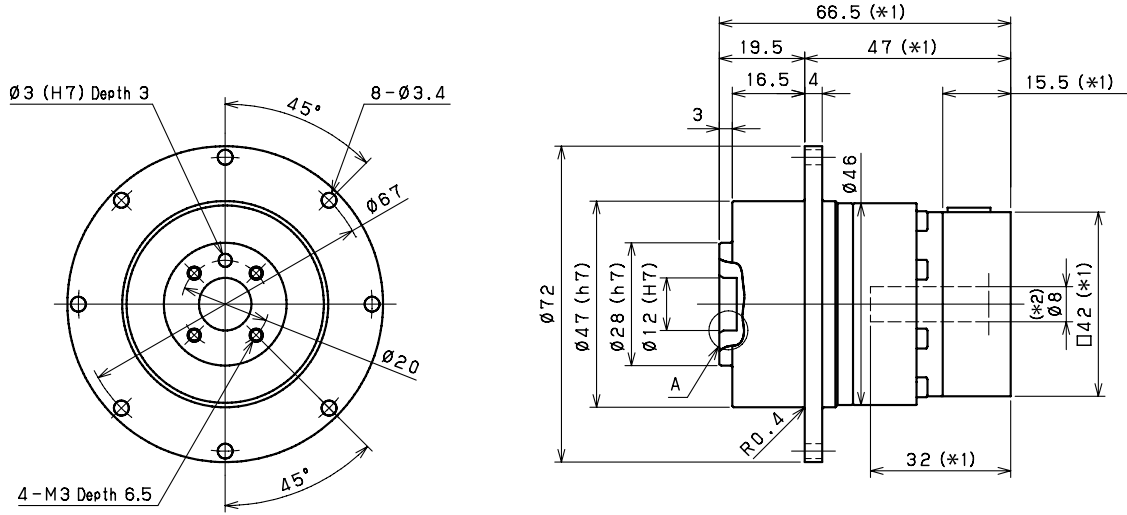

Input bore size $\leq \varnothing 14$ mm

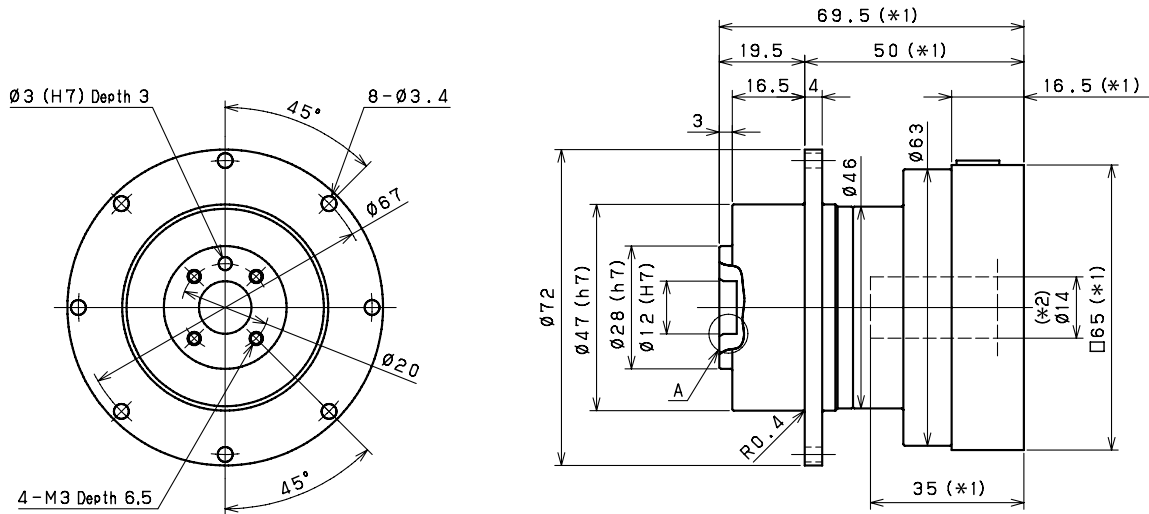

*1) Length will vary depending on motor

*2) Bushing will be inserted to adapt to motor shaft

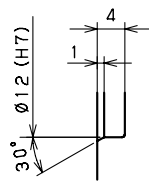

Enlarged detail A

VRT 047 2-Stage Dimensions

Input bore size $\leq \varnothing 8$ mm

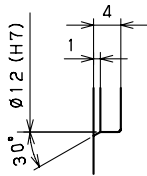
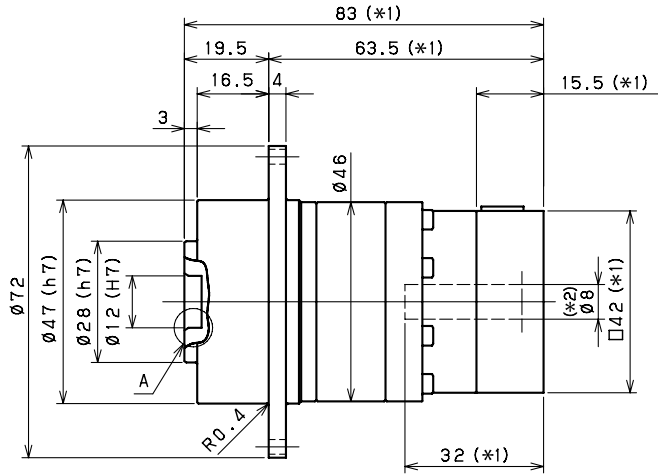
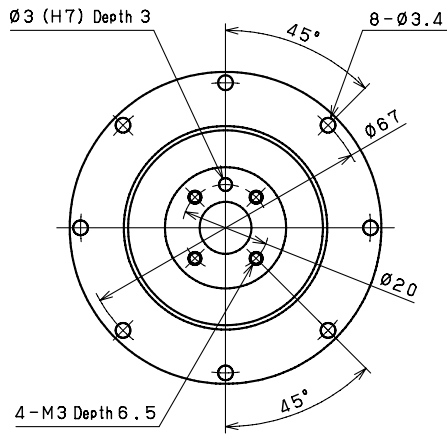

Enlarged detail A

*1) Length will vary depending on motor

*2) Bushing will be inserted to adapt to motor shaft

VRT SERIES Inline Planetary

VRT o64 1-Stage Specifications

Frame Size	064										
Ratio	Unit	Note	4	5	6	7	8	9	10		
Nominal Output Torque	[Nm]	*1	27	27	27	27	27	18	18		
Maximum Acceleration Torque	[Nm]	*2	50	50	50	50	50	35	35		
Emergency Stop Torque	[Nm]	*3	100	100	100	100	100	80	80		
Nominal Input Speed	[rpm]	*4	3000								
Maximum Input Speed	[rpm]	*5	6000								
No Load Running Torque	[Nm]	*6	0.08								
Permitted Radial Load	[N]	*7	370	400	420	440	460	480	500		
Permitted Axial Load	[N]	*8	360	390	430	460	480	510	530		
Maximum Radial Load	[N]	*9	1500								
Maximum Axial Load	[N]	*10	750								
Maximum Tilting Moment	[Nm]	*11	58								
Moment of Inertia ($\leq \emptyset 8$)	[kgcm ²]	--	0.13	0.10	0.085	0.075	0.068	0.064	0.062		
Moment of Inertia ($\leq \emptyset 14$)	[kgcm ²]	--	0.24	0.21	0.20	0.19	0.18	0.18	0.17		
Moment of Inertia ($\leq \emptyset 19$)	[kgcm ²]	--	0.52	0.49	0.47	0.46	0.46	0.45	0.45		
Efficiency	[%]	*12	95								
Torsional Rigidity	[Nm/arc-min]	*13	7.5								
Maximum Torsional Backlash	[arc-min]	--	≤ 3								
Noise Level	dB [A]	*14	≤ 66								
Protection Class	--	*15	IP54 (IP65)								
Ambient Temperature	[°C]	--	0 - 40								
Permitted Housing Temperature	[°C]	--	90								
Weight	[kg]	*16	1.4								

VRT o64 2-Stage Specifications

Frame Size	064										
Ratio	Unit	Note	16	20	25	28	35	40	45		
Nominal Output Torque	[Nm]	*1	27	27	27	27	27	27	18		
Maximum Acceleration Torque	[Nm]	*2	50	50	50	50	50	50	35		
Emergency Stop Torque	[Nm]	*3	100	100	100	100	100	100	80		
Nominal Input Speed	[rpm]	*4	3000								
Maximum Input Speed	[rpm]	*5	6000								
No Load Running Torque	[Nm]	*6	0.04								
Permitted Radial Load	[N]	*7	580	630	680	700	760	790	820		
Permitted Axial Load	[N]	*8	650	720	750	750	750	750	750		
Maximum Radial Load	[N]	*9	1500								
Maximum Axial Load	[N]	*10	750								
Maximum Tilting Moment	[Nm]	*11	58								
Moment of Inertia ($\leq \emptyset 8$)	[kgcm ²]	--	0.072	0.064	0.062	0.069	0.061	0.051	0.061		
Moment of Inertia ($\leq \emptyset 14$)	[kgcm ²]	--	0.18	0.18	0.17	0.18	0.17	0.16	0.17		
Moment of Inertia ($\leq \emptyset 19$)	[kgcm ²]	--	0.46	0.45	0.45	0.46	0.45	0.44	0.45		
Efficiency	[%]	*12	90								
Torsional Rigidity	[Nm/arc-min]	*13	7.5								
Maximum Torsional Backlash	[arc-min]	--	≤ 3								
Noise Level	dB [A]	*14	≤ 66								
Protection Class	--	*15	IP54 (IP65)								
Ambient Temperature	[°C]	--	0 - 40								
Permitted Housing Temperature	[°C]	--	90								
Weight	[kg]	*16	1.6								

VRT 064 2-Stage Specifications

Frame Size	064								
Ratio	Unit	Note	50	60	70	80	90	100	
Nominal Output Torque	[Nm]	*1	27	27	27	27	18	18	
Maximum Acceleration Torque	[Nm]	*2	50	50	50	50	35	35	
Emergency Stop Torque	[Nm]	*3	100	100	100	100	80	80	
Nominal Input Speed	[rpm]	*4	3000						
Maximum Input Speed	[rpm]	*5	6000						
No Load Running Torque	[Nm]	*6	0.04						
Permitted Radial Load	[N]	*7	850	910	950	1000	1000	1100	
Permitted Axial Load	[N]	*8	750	750	750	750	750	750	
Maximum Radial Load	[N]	*9	1500						
Maximum Axial Load	[N]	*10	750						
Maximum Tilting Moment	[Nm]	*11	58						
Moment of Inertia ($\leq \varnothing 8$)	[kgcm ²]	--	0.051	0.051	0.051	0.051	0.051	0.051	
Moment of Inertia ($\leq \varnothing 14$)	[kgcm ²]	--	0.16	0.16	0.16	0.16	0.16	0.16	
Moment of Inertia ($\leq \varnothing 19$)	[kgcm ²]	--	0.44	0.44	0.44	0.44	0.44	0.44	
Efficiency	[%]	*12	90						
Torsional Rigidity	[Nm/arc-min]	*13	7.5						
Maximum Torsional Backlash	[arc-min]	--	≤ 3						
Noise Level	dB [A]	*14	≤ 66						
Protection Class	--	*15	IP54 (IP65)						
Ambient Temperature	[°C]	--	0 - 40						
Permitted Housing Temperature	[°C]	--	90						
Weight	[kg]	*16	1.6						

*1) At nominal input speed, service life is 20,000 hours

*2) The maximum torque when starting or stopping operation

*3) The maximum torque allowed under a stress situation (Permitted 1,000 times during service life)

*4) The average input speed

*5) The maximum intermittent input speed

*6) Torque at no load applied to the input shaft at nominal input speed

*7) At this load and nominal input speed, service life will be 20,000 hours. (The radial load applied to the output side shaft center)

*8) At this load and nominal input speed, service life will be 20,000 hours. (The axial load applied to the output side bearing)

*9) The maximum radial load that the gearbox can accept

*10) The maximum axial load that the gearbox can accept

*11) The moment is the maximum load at output flange surface

*12) The efficiency at the nominal output torque rating

*13) This does not include lost motion

*14) Contact NIDEC-SHIMPO for the testing conditions and environment

*15) IP65 (wash-down) is available as an option. Contact NIDEC-SHIMPO for more details

*16) The weight may vary slightly between models

VRT SERIES Inline Planetary

VRT 090 1-Stage Specifications

Frame Size	090										
Ratio	Unit	Note	4	5	6	7	8	9	10		
Nominal Output Torque	[Nm]	*1	75	75	75	75	75	50	50		
Maximum Acceleration Torque	[Nm]	*2	125	125	125	125	125	80	80		
Emergency Stop Torque	[Nm]	*3	250	250	250	250	250	200	200		
Nominal Input Speed	[rpm]	*4	3000								
Maximum Input Speed	[rpm]	*5	6000								
No Load Running Torque	[Nm]	*6	0.17								
Permitted Radial Load	[N]	*7	720	780	830	870	910	950	980		
Permitted Axial Load	[N]	*8	620	680	740	790	830	880	920		
Maximum Radial Load	[N]	*9	3300								
Maximum Axial Load	[N]	*10	1700								
Maximum Tilting Moment	[Nm]	*11	170								
Moment of Inertia ($\leq \varnothing 14$)	[kgcm ²]	--	0.78	0.58	0.48	0.42	0.38	0.36	0.34		
Moment of Inertia ($\leq \varnothing 19$)	[kgcm ²]	--	1.2	0.98	0.87	0.82	0.78	0.75	0.74		
Moment of Inertia ($\leq \varnothing 28$)	[kgcm ²]	--	2.9	2.7	2.6	2.6	2.5	2.5	2.5		
Efficiency	[%]	*12	95								
Torsional Rigidity	[Nm/arc-min]	*13	22								
Maximum Torsional Backlash	[arc-min]	--	≤ 3								
Noise Level	dB [A]	*14	≤ 67								
Protection Class	--	*15	IP54 (IP65)								
Ambient Temperature	[°C]	--	0 - 40								
Permitted Housing Temperature	[°C]	--	90								
Weight	[kg]	*16	3.6								

VRT 090 2-Stage Specifications

Frame Size	090								
Ratio	Unit	Note	16	20	25	28	35	40	
Nominal Output Torque	[Nm]	*1	75	75	75	75	75	75	
Maximum Acceleration Torque	[Nm]	*2	125	125	125	125	125	125	
Emergency Stop Torque	[Nm]	*3	250	250	250	250	250	250	
Nominal Input Speed	[rpm]	*4	3000						
Maximum Input Speed	[rpm]	*5	6000						
No Load Running Torque	[Nm]	*6	0.05						
Permitted Radial Load	[N]	*7	1200	1200	1300	1400	1500	1600	
Permitted Axial Load	[N]	*8	1100	1200	1400	1400	1600	1700	
Maximum Radial Load	[N]	*9	3300						
Maximum Axial Load	[N]	*10	1700						
Maximum Tilting Moment	[Nm]	*11	170						
Moment of Inertia ($\leq \varnothing 8$)	[kgcm ²]	--	0.26	0.20	0.19	0.24	0.19	0.12	
Moment of Inertia ($\leq \varnothing 14$)	[kgcm ²]	--	0.43	0.36	0.36	0.40	0.35	0.28	
Moment of Inertia ($\leq \varnothing 19$)	[kgcm ²]	--	0.81	0.75	0.74	0.79	0.74	0.67	
Moment of Inertia ($\leq \varnothing 28$)	[kgcm ²]	--	2.5	2.5	2.5	2.5	2.5	2.4	
Efficiency	[%]	*12	90						
Torsional Rigidity	[Nm/arc-min]	*13	22						
Maximum Torsional Backlash	[arc-min]	--	≤ 3						
Noise Level	dB [A]	*14	≤ 67						
Protection Class	--	*15	IP54 (IP65)						
Ambient Temperature	[°C]	--	0 - 40						
Permitted Housing Temperature	[°C]	--	90						
Weight	[kg]	*16	4						

VRT 090 2-Stage Specifications

Frame Size	090										
Ratio	Unit	Note	45	50	60	70	80	90	100		
Nominal Output Torque	[Nm]	*1	50	75	75	75	75	50	50		
Maximum Acceleration Torque	[Nm]	*2	80	125	125	125	125	80	80		
Emergency Stop Torque	[Nm]	*3	200	250	250	250	250	200	200		
Nominal Input Speed	[rpm]	*4	3000								
Maximum Input Speed	[rpm]	*5	6000								
No Load Running Torque	[Nm]	*6	0.05								
Permitted Radial Load	[N]	*7	1600	1700	1800	1900	2000	2000	2100		
Permitted Axial Load	[N]	*8	1700	1700	1700	1700	1700	1700	1700		
Maximum Radial Load	[N]	*9	3300								
Maximum Axial Load	[N]	*10	1700								
Maximum Tilting Moment	[Nm]	*11	170								
Moment of Inertia (≤ Ø 8)	[kgcm ²]	--	0.19	0.12	0.11	0.11	0.11	0.11	0.11		
Moment of Inertia (≤ Ø 14)	[kgcm ²]	--	0.35	0.28	0.27	0.27	0.27	0.27	0.27		
Moment of Inertia (≤ Ø 19)	[kgcm ²]	--	0.73	0.67	0.67	0.67	0.67	0.67	0.67		
Moment of Inertia (≤ Ø 28)	[kgcm ²]	--	2.5	2.4	2.4	2.4	2.4	2.4	2.4		
Efficiency	[%]	*12	90								
Torsional Rigidity	[Nm/arc-min]	*13	22								
Maximum Torsional Backlash	[arc-min]	--	≤3								
Noise Level	dB [A]	*14	≤ 67								
Protection Class	--	*15	IP54 (IP65)								
Ambient Temperature	[°C]	--	0 - 40								
Permitted Housing Temperature	[°C]	--	90								
Weight	[kg]	*16	4								

*1) At nominal input speed, service life is 20,000 hours

*2) The maximum torque when starting or stopping operation

*3) The maximum torque allowed under a stress situation (Permitted 1,000 times during service life)

*4) The average input speed

*5) The maximum intermittent input speed

*6) Torque at no load applied to the input shaft at nominal input speed

*7) At this load and nominal input speed, service life will be 20,000 hours. (The radial load applied to the output side shaft center)

*8) At this load and nominal input speed, service life will be 20,000 hours. (The axial load applied to the output side bearing)

*9) The maximum radial load that the gearbox can accept

*10) The maximum axial load that the gearbox can accept

*11) The moment is the maximum load at output flange surface

*12) The efficiency at the nominal output torque rating

*13) This does not include lost motion

*14) Contact NIDEC-SHIMPO for the testing conditions and environment

*15) IP65 (wash-down) is available as an option. Contact NIDEC-SHIMPO for more details

*16) The weight may vary slightly between models

VRT SERIES Inline Planetary

VRT 090 1-Stage Dimensions

Input bore size $\cong \varnothing 14$ mm

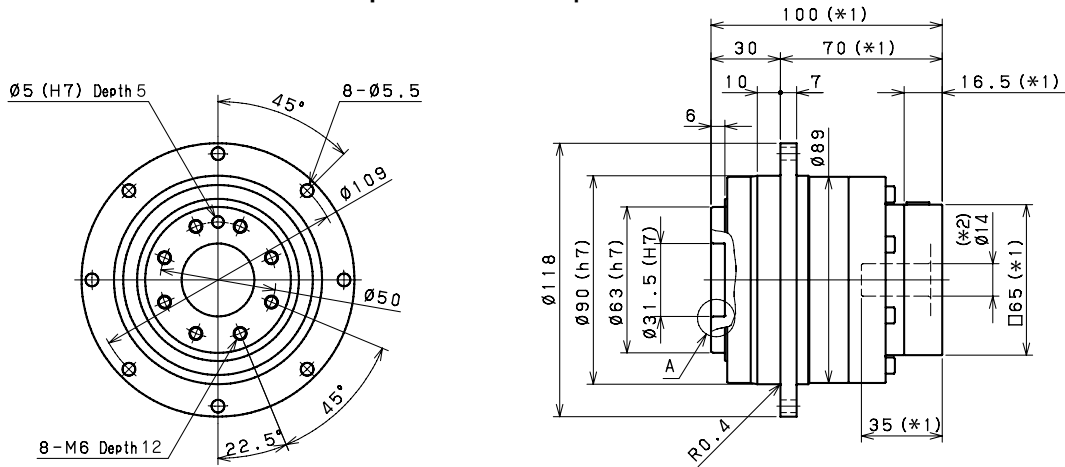

Input bore size $\cong \varnothing 19$ mm

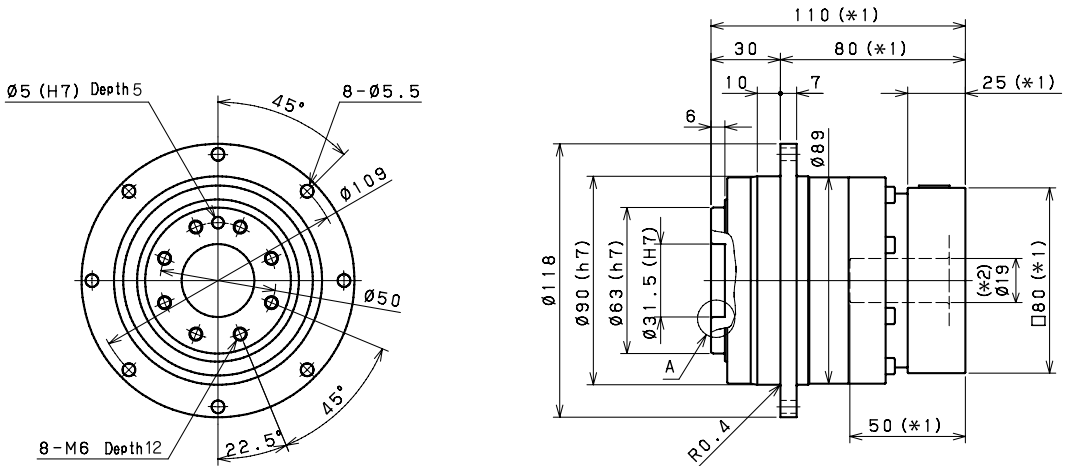

Input bore size $\cong \varnothing 28$ mm

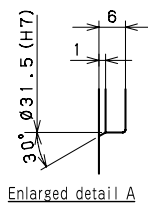
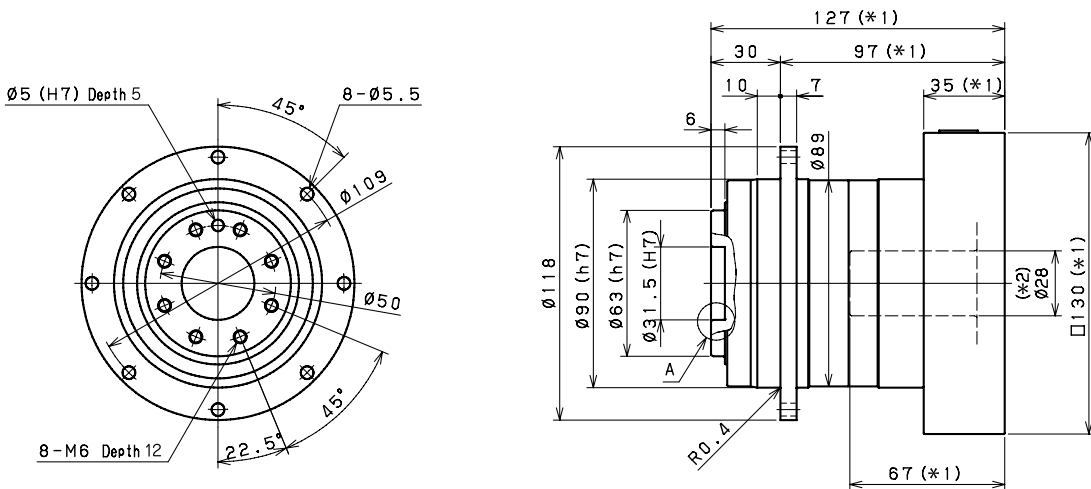

*1) Length will vary depending on motor

*2) Bushing will be inserted to adapt to motor shaft

VRT 090 2-Stage Dimensions

Input bore size $\leq \varnothing 8 \text{ mm}$

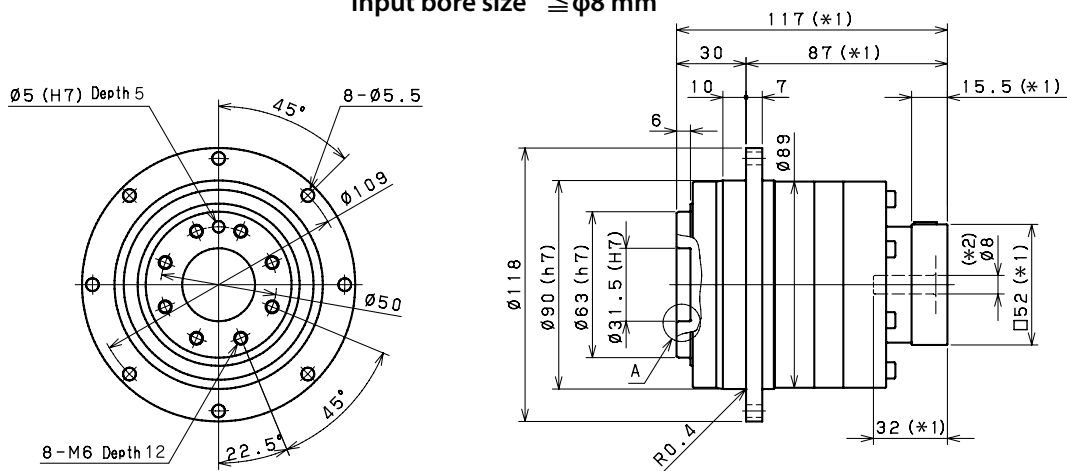

Input bore size $\leq \varnothing 14 \text{ mm}$

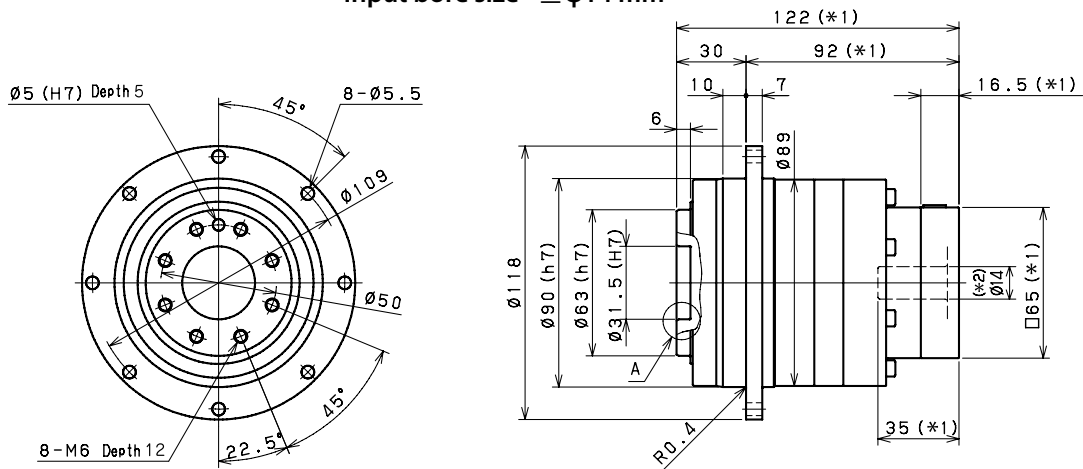

Input bore size $\leq \varnothing 19 \text{ mm}$ (*3)

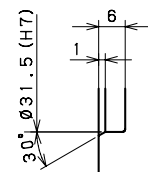
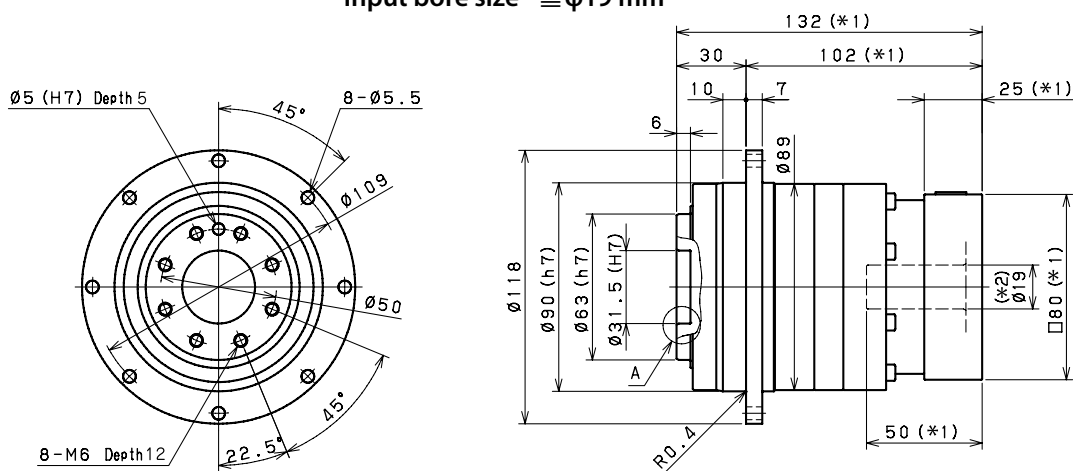

Enlarged detail A

*1) Length will vary depending on motor

*2) Bushing will be inserted to adapt to motor shaft

*3) 28mm input bore is available for this frame size. Use our online configurator to make your selection or contact us for assistance

VRT 110 1-Stage Specifications

Frame Size	110					
Ratio	Unit	Note	4	5	7	10
Nominal Output Torque	[Nm]	*1	120	180	180	120
Maximum Output Torque	[Nm]	*2	330	330	330	225
Emergency Stop Torque	[Nm]	*3	625	625	625	500
Nominal Input Speed	[rpm]	*4	3000			
Maximum Input Speed	[rpm]	*5	6000			
No Load Running Torque	[Nm]	*6	0.77			
Permitted Radial Load	[N]	*7	4700	5000	5600	6200
Permitted Axial Load	[N]	*8	3200	3400	3800	4200
Maximum Radial Load	[N]	*9	12000			
Maximum Axial Load	[N]	*10	8800			
Maximum Tilting Moment	[Nm]	*11	990			
Moment of Inertia ($\leq \varnothing 19$)	[kgcm ²]	--	3.1	2.1	1.3	0.99
Moment of Inertia ($\leq \varnothing 28$)	[kgcm ²]	--	4.8	3.8	3.1	2.7
Moment of Inertia ($\leq \varnothing 38$)	[kgcm ²]	--	11	10	9.5	9.0
Efficiency	[%]	*12	95			
Torsional Rigidity	[Nm/arcmin]	*13	60			
Maximum Torsional Backlash	[Arc-min]	--	≤ 3			
Noise Level	dB [A]	*14	≤ 71			
Protection Class	--	*15	IP54 (IP65)			
Ambient Temperature	[°C]	--	0 - 40			
Permitted Housing Temperature	[°C]	--	90			
Weight	[kg]	*16	7.8			

VRT 110 2-Stage Specifications

Frame Size	110					
Ratio	Unit	Note	16	20	25	28
Nominal Output Torque	[Nm]	*1	180	180	180	180
Maximum Output Torque	[Nm]	*2	330	330	330	330
Emergency Stop Torque	[Nm]	*3	625	625	625	625
Nominal Input Speed	[rpm]	*4	3000			
Maximum Input Speed	[rpm]	*5	6000			
No Load Running Torque	[Nm]	*6	0.17			
Permitted Radial Load	[N]	*7	7100	7600	8200	8500
Permitted Axial Load	[N]	*8	4800	5200	5500	5700
Maximum Radial Load	[N]	*9	12000			
Maximum Axial Load	[N]	*10	8800			
Maximum Tilting Moment	[Nm]	*11	990			
Moment of Inertia ($\leq \varnothing 8$)	[kgcm ²]	--	-	-	-	-
Moment of Inertia ($\leq \varnothing 14$)	[kgcm ²]	--	1.0	0.76	0.73	0.94
Moment of Inertia ($\leq \varnothing 19$)	[kgcm ²]	--	1.4	1.1	1.1	1.3
Moment of Inertia ($\leq \varnothing 28$)	[kgcm ²]	--	3.2	2.9	2.9	3.1
Moment of Inertia ($\leq \varnothing 38$)	[kgcm ²]	--	9.5	9.2	9.1	9.4
Efficiency	[%]	*12	90			
Torsional Rigidity	[Nm/arcmin]	*13	60			
Maximum Torsional Backlash	[Arc-min]	--	≤ 3			
Noise Level	dB [A]	*14	≤ 71			
Protection Class	--	*15	IP54 (IP65)			
Ambient Temperature	[°C]	--	0 - 40			
Permitted Housing Temperature	[°C]	--	90			
Weight	[kg]	*16	8.6			

VRT 110 2-Stage Specifications

Frame Size	110							
Ratio	Unit	Note	35	40	50	70	100	
Nominal Output Torque	[Nm]	*1	180	180	180	180	120	
Maximum Output Torque	[Nm]	*2	330	330	330	330	225	
Emergency Stop Torque	[Nm]	*3	625	625	625	625	500	
Nominal Input Speed	[rpm]	*4	3000					
Maximum Input Speed	[rpm]	*5	6000					
No Load Running Torque	[Nm]	*6	0.17					
Permitted Radial Load	[N]	*7	9000	9400	10000	11000	12000	
Permitted Axial Load	[N]	*8	6100	6400	6800	7500	8400	
Maximum Radial Load	[N]	*9	12000					
Maximum Axial Load	[N]	*10	8800					
Maximum Tilting Moment	[Nm]	*11	990					
Moment of Inertia (≤ Ø 8)	[kgcm ²]	--	-	-	0.20	0.19	0.19	
Moment of Inertia (≤ Ø 14)	[kgcm ²]	--	0.70	0.38	0.37	0.36	0.36	
Moment of Inertia (≤ Ø 19)	[kgcm ²]	--	1.1	0.78	0.77	0.76	0.76	
Moment of Inertia (≤ Ø 28)	[kgcm ²]	--	2.8	2.5	2.5	2.5	2.5	
Moment of Inertia (≤ Ø 38)	[kgcm ²]	--	9.1	8.8	8.8	8.8	8.8	
Efficiency	[%]	*12	90					
Torsional Rigidity	[Nm/arcmin]	*13	60					
Maximum Torsional Backlash	[Arc-min]	--	≤ 3					
Noise Level	dB [A]	*14	≤ 71					
Protection Class	--	*15	IP54 (IP65)					
Ambient Temperature	[°C]	--	0 - 40					
Permitted Housing Temperature	[°C]	--	90					
Weight	[kg]	*16	8.6					

*1) At nominal input speed, service life is 20,000 hours

*2) The maximum torque when starting or stopping operation

*3) The maximum torque allowed under a stress situation (Permitted 1,000 times during service life)

*4) The average input speed

*5) The maximum intermittent input speed

*6) Torque at no load applied to the input shaft at nominal input speed

*7) At this load and nominal input speed, service life will be 20,000 hours. (The radial load applied to the output side shaft center)

*8) At this load and nominal input speed, service life will be 20,000 hours. (The axial load applied to the output side bearing)

*9) The maximum radial load that the gearbox can accept

*10) The maximum axial load that the gearbox can accept

*11) The moment is the maximum load at output flange surface

*12) The efficiency at the nominal output torque rating

*13) This does not include lost motion

*14) Contact NIDEC-SHIMPO for the testing conditions and environment

*15) IP65 (wash-down) is available as an option. Contact NIDEC-SHIMPO for more details

*16) The weight may vary slightly between models

VRT 110 2-Stage Dimensions

Input bore size $\geq \phi 14$ mm

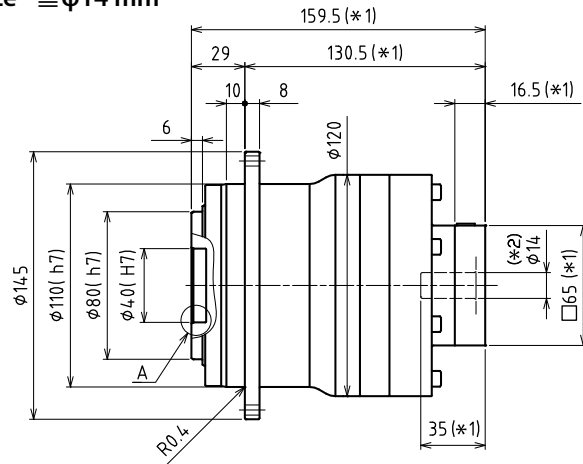
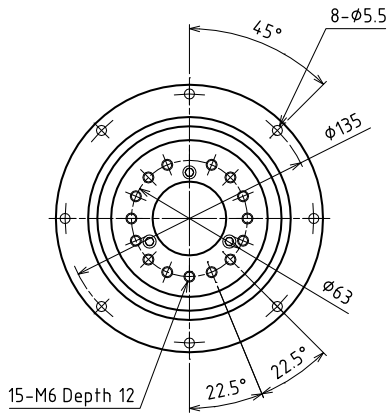

Input bore size $\geq \phi 19$ mm

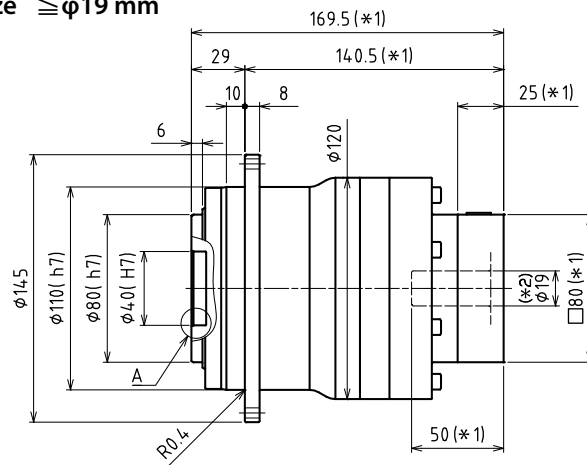
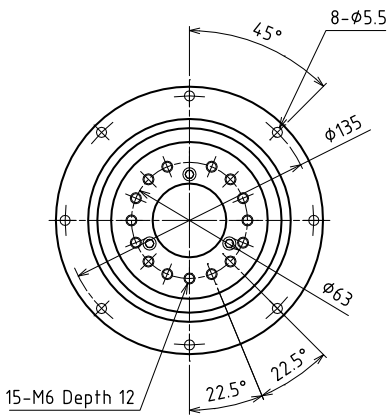

Input bore size $\geq \phi 28$ mm^(*3)

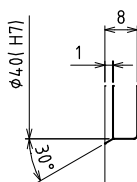
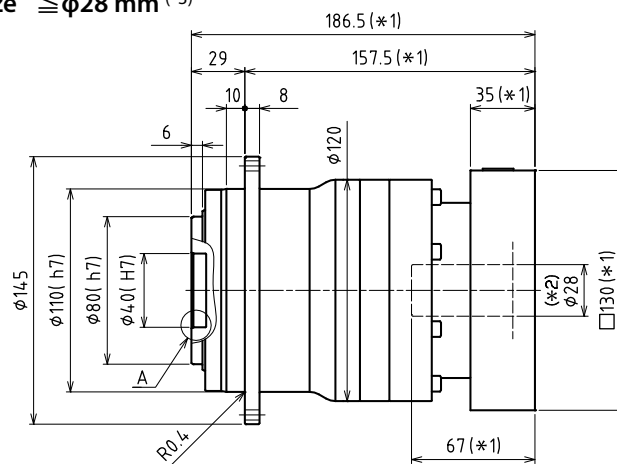
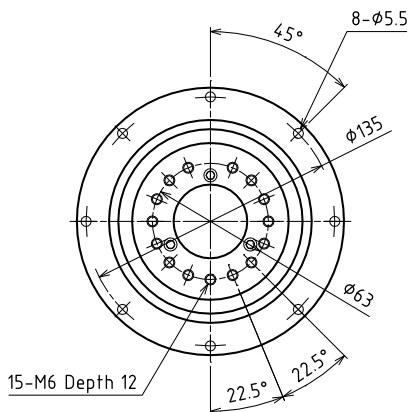

Enlarged detail A

*1) Length will vary depending on motor

*2) Bushing will be inserted to adapt to motor shaft

*3) 38mm input bore is available for this frame size. Use our online configurator to make your selection or contact us for assistance

VRT SERIES Inline Planetary

VRT 140 1-Stage Specifications

Frame Size	140					
Ratio	Unit	Note	4	5	7	10
Nominal Output Torque	[Nm]	*1	240	360	360	240
Maximum Output Torque	[Nm]	*2	700	700	700	470
Emergency Stop Torque	[Nm]	*3	1250	1250	1250	1000
Nominal Input Speed	[rpm]	*4	2000			
Maximum Input Speed	[rpm]	*5	4000			
No Load Running Torque	[Nm]	*6	1.00			
Permitted Radial Load	[N]	*7	8000	8500	9400	10000
Permitted Axial Load	[N]	*8	5600	6000	6700	7400
Maximum Radial Load	[N]	*9	19000			
Maximum Axial Load	[N]	*10	14000			
Maximum Tilting Moment	[Nm]	*11	2000			
Moment of Inertia ($\leq \varnothing 28$)	[kgcm ²]	--	11	7.7	5.1	3.8
Moment of Inertia ($\leq \varnothing 38$)	[kgcm ²]	--	18	14	12	10
Moment of Inertia ($\leq \varnothing 48$)	[kgcm ²]	--	33	29	27	25
Efficiency	[%]	*12	95			
Torsional Rigidity	[Nm/arcmin]	*13	140			
Maximum Torsional Backlash	[Arc-min]	*14	≤ 3			
Noise Level	dB [A]	--	≤ 67			
Protection Class	--	*15	IP54 (IP65)			
Ambient Temperature	[°C]	--	0 - 40			
Permitted Housing Temperature	[°C]	--	90			
Weight	[kg]	*16	15			

VRT 140 2-Stage Specifications

Frame Size	140					
Ratio	Unit	Note	16	20	25	28
Nominal Output Torque	[Nm]	*1	360	360	360	360
Maximum Output Torque	[Nm]	*2	700	700	700	700
Emergency Stop Torque	[Nm]	*3	1250	1250	1250	1250
Nominal Input Speed	[rpm]	*4	2000			
Maximum Input Speed	[rpm]	*5	4000			
No Load Running Torque	[Nm]	*6	0.54			
Permitted Radial Load	[N]	*7	12000	13000	14000	14000
Permitted Axial Load	[N]	*8	8500	9100	9800	10000
Maximum Radial Load	[N]	*9	19000			
Maximum Axial Load	[N]	*10	14000			
Maximum Tilting Moment	[Nm]	*11	2000			
Moment of Inertia ($\leq \varnothing 14$)	[kgcm ²]	--	-	-	-	-
Moment of Inertia ($\leq \varnothing 19$)	[kgcm ²]	--	3.8	2.6	2.5	3.4
Moment of Inertia ($\leq \varnothing 28$)	[kgcm ²]	--	5.5	4.3	4.2	5.1
Moment of Inertia ($\leq \varnothing 38$)	[kgcm ²]	--	12	11	11	11
Moment of Inertia ($\leq \varnothing 48$)	[kgcm ²]	--	27	26	25	26
Efficiency	[%]	*12	90			
Torsional Rigidity	[Nm/arcmin]	*13	140			
Maximum Torsional Backlash	[Arc-min]	*14	≤ 3			
Noise Level	dB [A]	--	≤ 67			
Protection Class	--	*15	IP54 (IP65)			
Ambient Temperature	[°C]	--	0 - 40			
Permitted Housing Temperature	[°C]	--	90			
Weight	[kg]	*16	17			

VRT 140 2-Stage Specifications

Frame Size	140							
Ratio	Unit	Note	35	40	50	70	100	
Nominal Output Torque	[Nm]	*1	360	360	360	360	240	
Maximum Output Torque	[Nm]	*2	700	700	700	700	470	
Emergency Stop Torque	[Nm]	*3	1250	1250	1250	1250	1000	
Nominal Input Speed	[rpm]	*4	2000					
Maximum Input Speed	[rpm]	*5	4000					
No Load Running Torque	[Nm]	*6	0.54					
Permitted Radial Load	[N]	*7	15000	16000	17000	19000	19000	
Permitted Axial Load	[N]	*8	11000	11000	12000	13000	14000	
Maximum Radial Load	[N]	*9	19000					
Maximum Axial Load	[N]	*10	14000					
Maximum Tilting Moment	[Nm]	*11	2000					
Moment of Inertia (≤ Ø 14)	[kgcm ²]	--	-	-	0.68	0.65	0.64	
Moment of Inertia (≤ Ø 19)	[kgcm ²]	--	2.4	1.1	1.1	1.1	1.1	
Moment of Inertia (≤ Ø 28)	[kgcm ²]	--	4.1	2.9	2.9	2.8	2.8	
Moment of Inertia (≤ Ø 38)	[kgcm ²]	--	10	9.2	9.1	9.1	9.1	
Moment of Inertia (≤ Ø 48)	[kgcm ²]	--	25	24	24	24	24	
Efficiency	[%]	*12	90					
Torsional Rigidity	[Nm/arcmin]	*13	140					
Maximum Torsional Backlash	[Arc-min]	*14	≤ 3					
Noise Level	dB [A]	--	≤ 67					
Protection Class	--	*15	IP54 (IP65)					
Ambient Temperature	[°C]	--	0 - 40					
Permitted Housing Temperature	[°C]	--	90					
Weight	[kg]	*16	17					

*1) At nominal input speed, service life is 20,000 hours

*2) The maximum torque when starting or stopping operation

*3) The maximum torque allowed under a stress situation (Permitted 1,000 times during service life)

*4) The average input speed

*5) The maximum intermittent input speed

*6) Torque at no load applied to the input shaft at nominal input speed

*7) At this load and nominal input speed, service life will be 20,000 hours. (The radial load applied to the output side shaft center)

*8) At this load and nominal input speed, service life will be 20,000 hours. (The axial load applied to the output side bearing)

*9) The maximum radial load that the gearbox can accept

*10) The maximum axial load that the gearbox can accept

*11) The moment is the maximum load at output flange surface

*12) The efficiency at the nominal output torque rating

*13) This does not include lost motion

*14) Contact NIDEC-SHIMPO for the testing conditions and environment

*15) IP65 (wash-down) is available as an option. Contact NIDEC-SHIMPO for more details

*16) The weight may vary slightly between models

VRT SERIES Inline Planetary

VRT 140 1-Stage Dimensions

Input bore size $\leq \varnothing 28$ mm

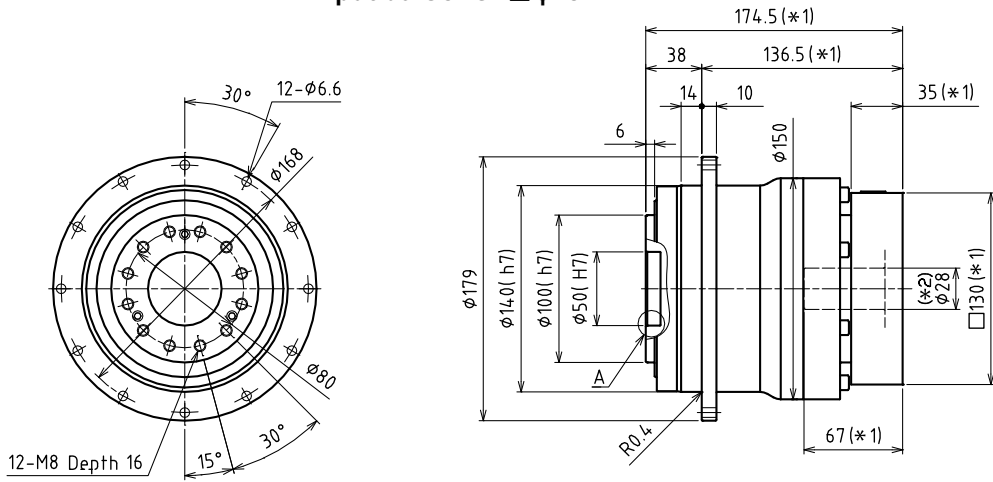

Input bore size $\leq \varnothing 38$ mm

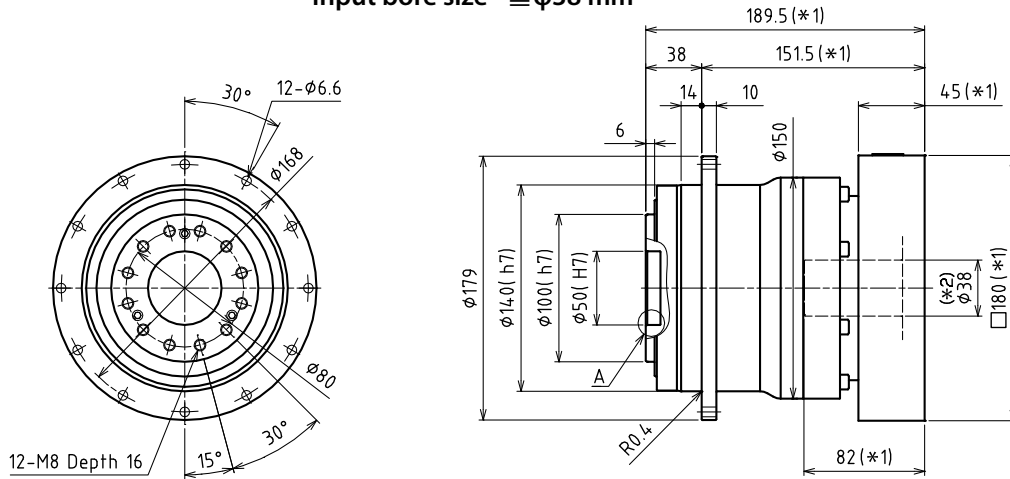

Input bore size $\leq \varnothing 48$ mm

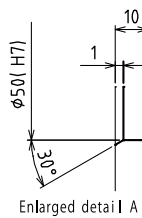
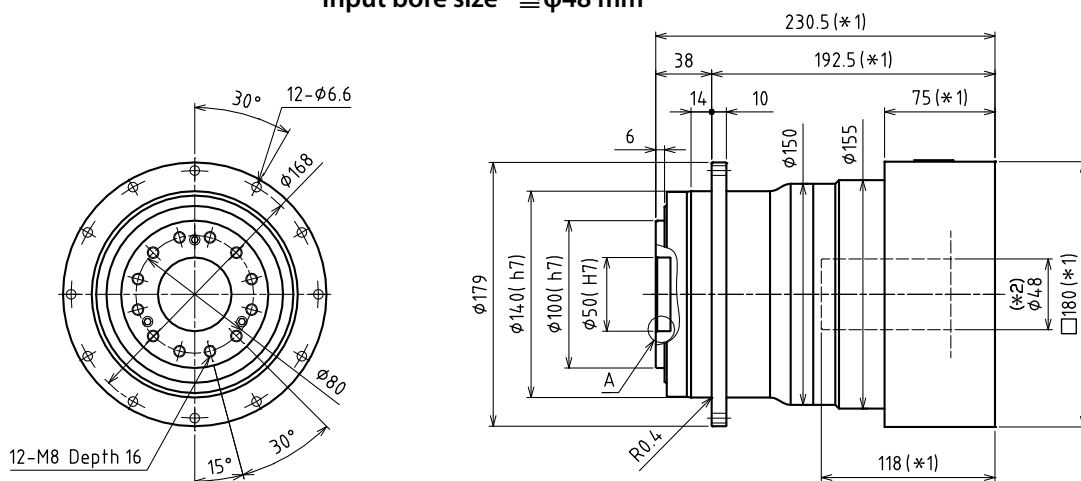

*1) Length will vary depending on motor.

*2) Bushing will be inserted to adapt to motor shaft

VRT 140 2-Stage Dimensions

Input bore size $\leq \phi 19$ mm

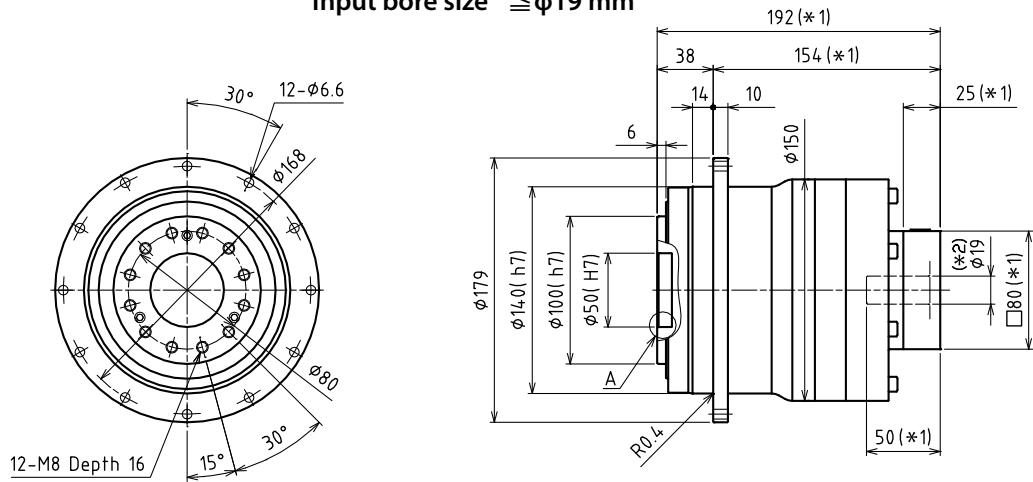

Input bore size $\leq \phi 28$ mm

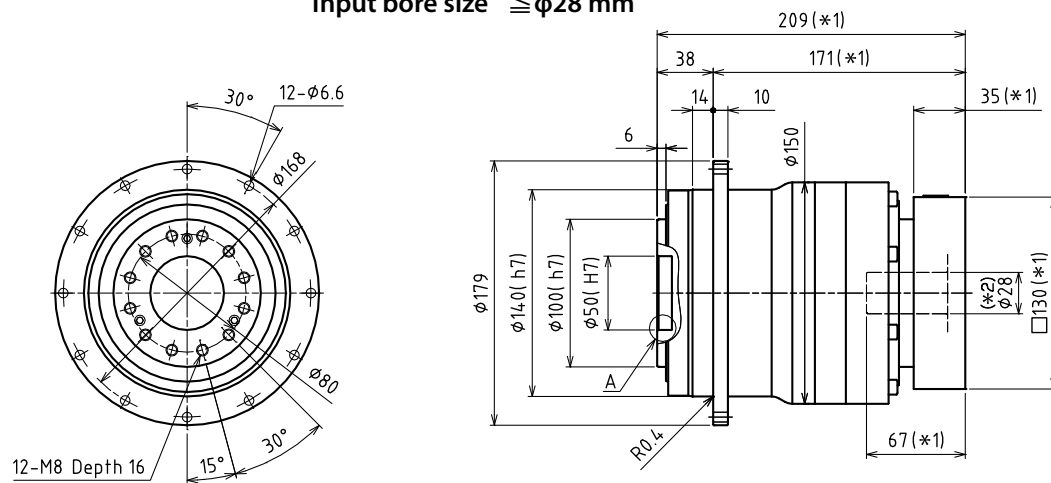

Input bore size $\leq \phi 38$ mm^(*3)

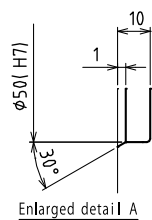
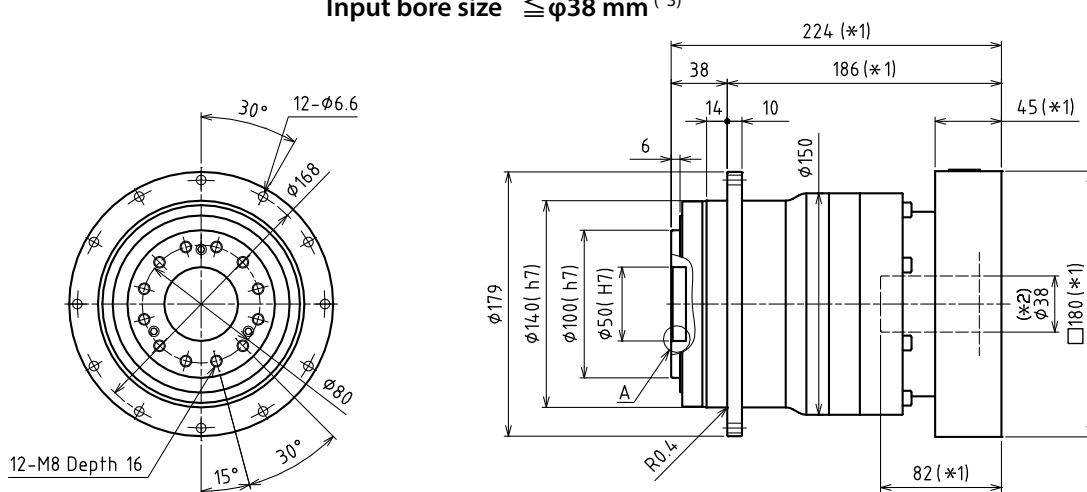

*1) Length will vary depending on motor

*2) Bushing will be inserted to adapt to motor shaft

*3) 48mm input bore is available for this frame size. Use our online configurator to make your selection or contact us for assistance

VRT SERIES Inline Planetary

VRT 200 1-Stage Specifications

Frame Size	200					
Ratio	Unit	Note	4	5	7	10
Nominal Output Torque	[Nm]	*1	750	750	750	500
Maximum Output Torque	[Nm]	*2	1400	1400	1400	970
Emergency Stop Torque	[Nm]	*3	2750	2750	2750	2200
Nominal Input Speed	[rpm]	*4	1500			
Maximum Input Speed	[rpm]	*5	3000			
No Load Running Torque	[Nm]	*6	1.9			
Permitted Radial Load	[N]	*7	18000	19000	21000	23000
Permitted Axial Load	[N]	*8	12000	13000	14000	16000
Maximum Radial Load	[N]	*9	40000			
Maximum Axial Load	[N]	*10	30000			
Maximum Tilting Moment	[Nm]	*11	5300			
Moment of Inertia ($\leq \varnothing 38$)	[kgcm ²]	--	53	36	23	16
Moment of Inertia ($\leq \varnothing 48$)	[kgcm ²]	--	68	51	37	31
Moment of Inertia ($\leq \varnothing 65$)	[kgcm ²]	--	110	95	81	75
Efficiency	[%]	*12	95			
Torsional Rigidity	[Nm/arcmin]	*13	320			
Maximum Torsional Backlash	[Arc-min]	*14	≤ 3			
Noise Level	dB [A]	--	≤ 67			
Protection Class	--	*15	IP54 (IP65)			
Ambient Temperature	[°C]	--	0 - 40			
Permitted Housing Temperature	[°C]	--	90			
Weight	[kg]	*16	42			

VRT 200 2-Stage Specifications

Frame Size	200					
Ratio	Unit	Note	16	20	25	28
Nominal Output Torque	[Nm]	*1	750	750	750	750
Maximum Output Torque	[Nm]	*2	1400	1400	1400	1400
Emergency Stop Torque	[Nm]	*3	2750	2750	2750	2750
Nominal Input Speed	[rpm]	*4	1500			
Maximum Input Speed	[rpm]	*5	3000			
No Load Running Torque	[Nm]	*6	1.3			
Permitted Radial Load	[N]	*7	27000	28000	30000	31000
Permitted Axial Load	[N]	*8	18000	19000	21000	21000
Maximum Radial Load	[N]	*9	40000			
Maximum Axial Load	[N]	*10	30000			
Maximum Tilting Moment	[Nm]	*11	5300			
Moment of Inertia ($\leq \varnothing 19$)	[kgcm ²]	--	-	-	-	-
Moment of Inertia ($\leq \varnothing 28$)	[kgcm ²]	--	13	9.2	8.6	11
Moment of Inertia ($\leq \varnothing 38$)	[kgcm ²]	--	19	15	15	18
Moment of Inertia ($\leq \varnothing 48$)	[kgcm ²]	--	34	30	30	32
Efficiency	[%]	*12	90			
Torsional Rigidity	[Nm/arcmin]	*13	320			
Maximum Torsional Backlash	[Arc-min]	*14	≤ 3			
Noise Level	dB [A]	--	≤ 67			
Protection Class	--	*15	IP54 (IP65)			
Ambient Temperature	[°C]	--	0 - 40			
Permitted Housing Temperature	[°C]	--	90			
Weight	[kg]	*16	43			

VRT 200 2-Stage Specifications

Frame Size	200							
Ratio	Unit	Note	35	40	50	70	100	
Nominal Output Torque	[Nm]	*1	750	750	750	750	500	
Maximum Output Torque	[Nm]	*2	1400	1400	1400	1400	970	
Emergency Stop Torque	[Nm]	*3	2750	2750	2750	2750	2200	
Nominal Input Speed	[rpm]	*4	1500					
Maximum Input Speed	[rpm]	*5	3000					
No Load Running Torque	[Nm]	*6	1.3					
Permitted Radial Load	[N]	*7	34000	35000	37000	40000	40000	
Permitted Axial Load	[N]	*8	23000	24000	25000	28000	30000	
Maximum Radial Load	[N]	*9	40000					
Maximum Axial Load	[N]	*10	30000					
Maximum Tilting Moment	[Nm]	*11	5300					
Moment of Inertia (≤ Ø 19)	[kgcm ²]	--	-	-	2.1	1.9	1.9	
Moment of Inertia (≤ Ø 28)	[kgcm ²]	--	8.0	4.1	4.0	3.8	3.8	
Moment of Inertia (≤ Ø 38)	[kgcm ²]	--	14	10	10	10	10	
Moment of Inertia (≤ Ø 48)	[kgcm ²]	--	29	25	25	25	25	
Efficiency	[%]	*12	90					
Torsional Rigidity	[Nm/arcmin]	*13	320					
Maximum Torsional Backlash	[Arc-min]	*14	≤ 3					
Noise Level	dB [A]	--	≤ 67					
Protection Class	--	*15	IP54 (IP65)					
Ambient Temperature	[°C]	--	0 - 40					
Permitted Housing Temperature	[°C]	--	90					
Weight	[kg]	*16	43					

- *1) At nominal input speed, service life is 20,000 hours
- *2) The maximum torque when starting or stopping operation
- *3) The maximum torque allowed under a stress situation (Permitted 1,000 times during service life)
- *4) The average input speed
- *5) The maximum intermittent input speed
- *6) Torque at no load applied to the input shaft at nominal input speed
- *7) At this load and nominal input speed, service life will be 20,000 hours. (The radial load applied to the output side shaft center)
- *8) At this load and nominal input speed, service life will be 20,000 hours. (The axial load applied to the output side bearing)
- *9) The maximum radial load that the gearbox can accept
- *10) The maximum axial load that the gearbox can accept
- *11) The moment is the maximum load at output flange surface
- *12) The efficiency at the nominal output torque rating
- *13) This does not include lost motion
- *14) Contact NIDEC-SHIMPO for the testing conditions and environment
- *15) IP65 (wash-down) is available as an option. Contact NIDEC-SHIMPO for more details
- *16) The weight may vary slightly between models

VRT SERIES Inline Planetary

VRT 200 1-Stage Dimensions

Input bore size $\cong \phi 38$ mm

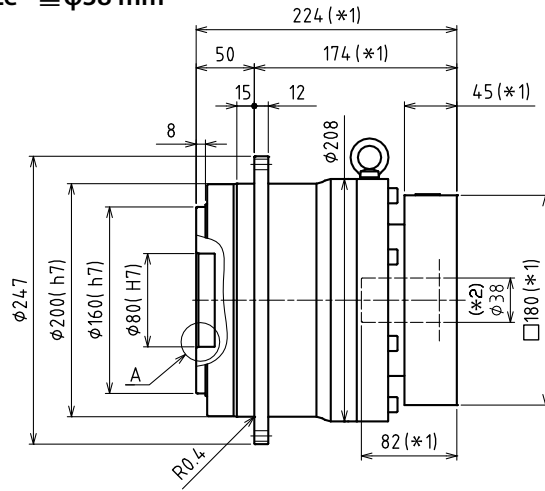
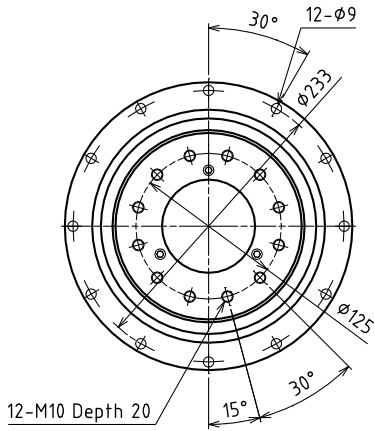

Input bore size $\cong \phi 48$ mm

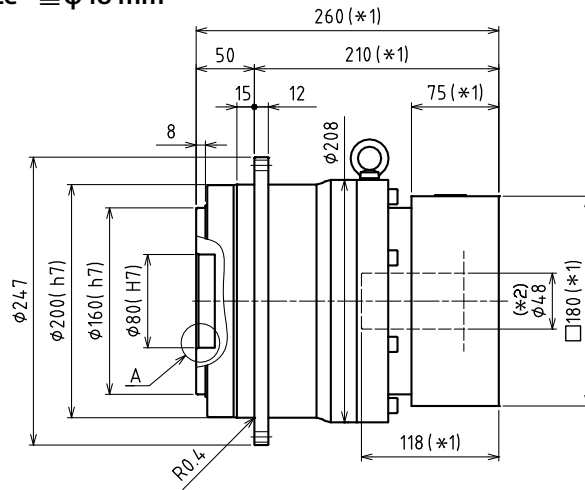
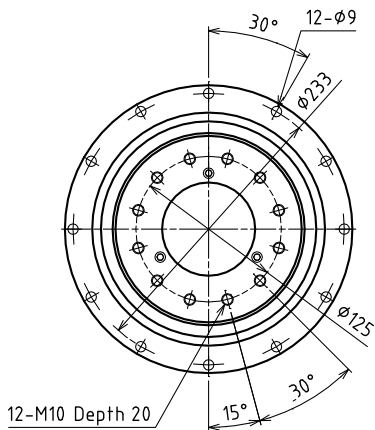

Input bore size $\cong \phi 65$ mm

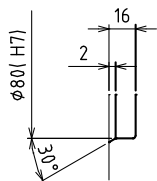
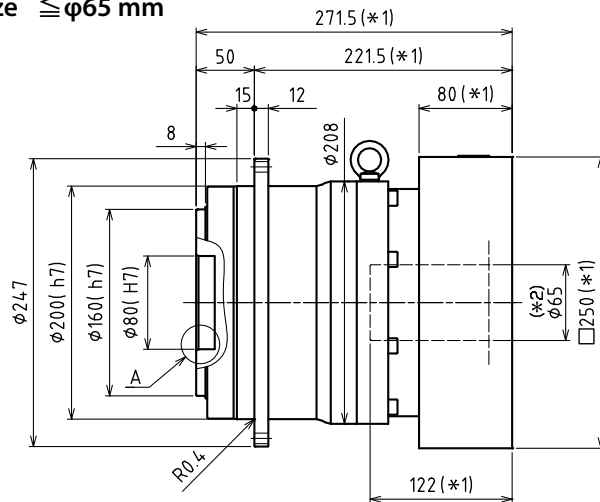
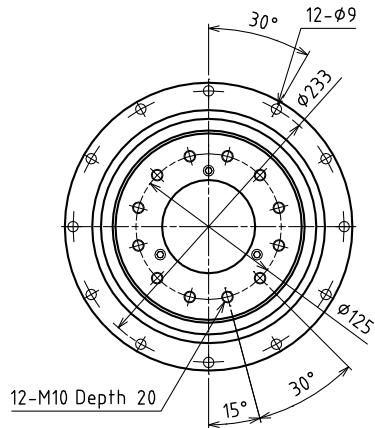

Enlarged detail A

- *1) Length will vary depending on motor
- *2) Bushing will be inserted to adapt to motor shaft

VRT 200 2-Stage Dimensions

Input bore size $\leq \phi 28$ mm

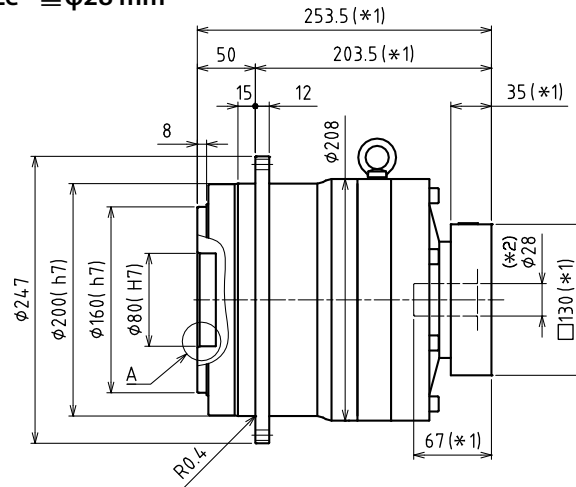
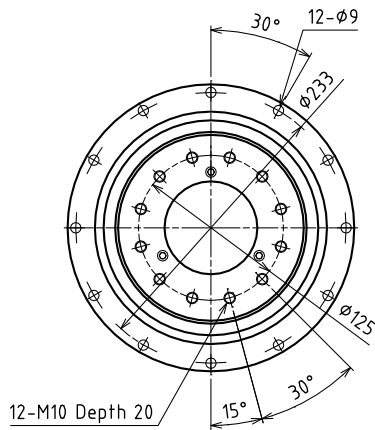

Input bore size $\leq \phi 38$ mm

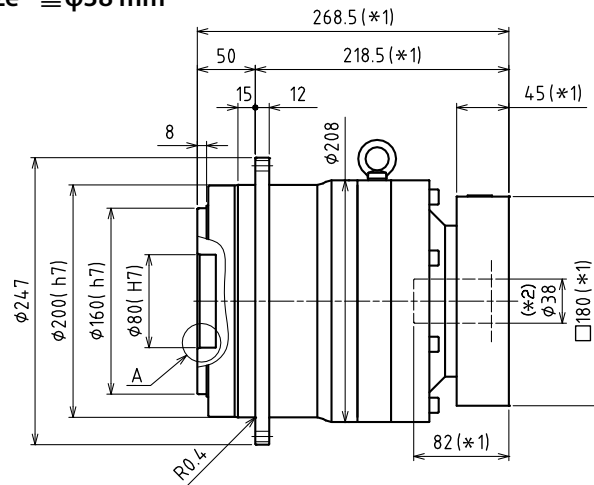
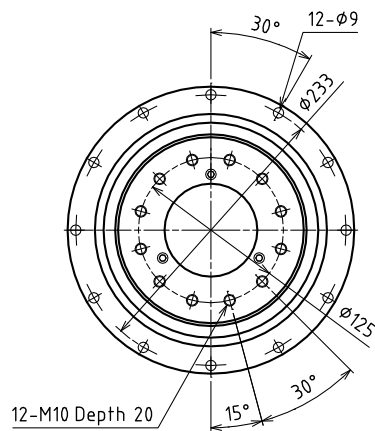

Input bore size $\leq \phi 48$ mm

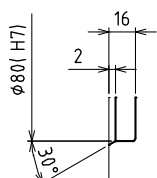
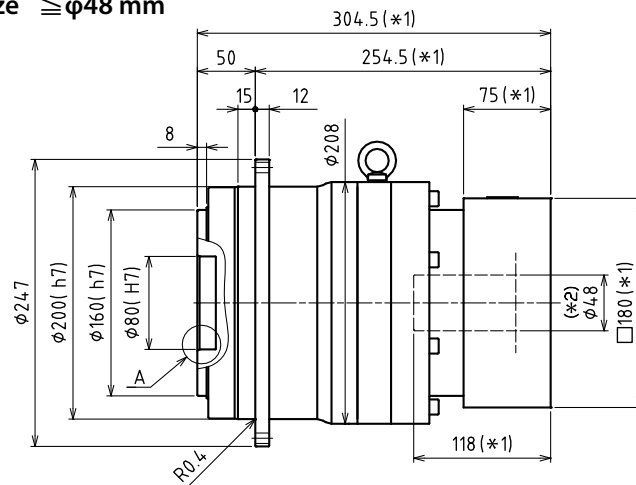
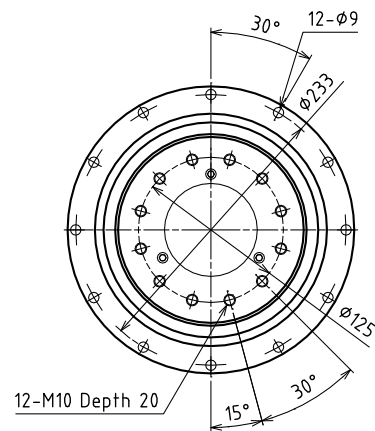

Enlarged detail A

*1) Length will vary depending on motor

*2) Bushing will be inserted to adapt to motor shaft

VRT SERIES Inline Planetary

VRT 255 1-Stage Specifications

Frame Size	255					
Ratio	Unit	Note	4	5	7	10
Nominal Output Torque	[Nm]	*1	2400	2400	2400	1600
Maximum Output Torque	[Nm]	*2	3700	3700	3700	2600
Emergency Stop Torque	[Nm]	*3	8000	8000	8000	6000
Nominal Input Speed	[rpm]	*4	1000			
Maximum Input Speed	[rpm]	*5	2000			
No Load Running Torque	[Nm]	*6	2.5			
Permitted Radial Load	[N]	*7	31000	33000	36000	40000
Permitted Axial Load	[N]	*8	22000	24000	26000	29000
Maximum Radial Load	[N]	*9	64000			
Maximum Axial Load	[N]	*10	48000			
Maximum Tilting Moment	[Nm]	*11	11000			
Moment of Inertia ($\leq \varnothing 65$)	[kgcm ²]	--	180	130	100	84
Efficiency	[%]	*12	95			
Torsional Rigidity	[Nm/arcmin]	*13	840			
Maximum Torsional Backlash	[Arc-min]	*14	≤ 3			
Noise Level	dB [A]	--	≤ 62			
Protection Class	--	*15	IP54 (IP65)			
Ambient Temperature	[°C]	--	0 - 40			
Permitted Housing Temperature	[°C]	--	90			
Weight	[kg]	*16	84			

VRT 255 2-Stage Specifications

Frame Size	255					
Ratio	Unit	Note	16	20	25	28
Nominal Output Torque	[Nm]	*1	2400	2400	2400	2400
Maximum Output Torque	[Nm]	*2	3700	3700	3700	3700
Emergency Stop Torque	[Nm]	*3	8000	8000	8000	8000
Nominal Input Speed	[rpm]	*4	1000			
Maximum Input Speed	[rpm]	*5	2000			
No Load Running Torque	[Nm]	*6	1.0			
Permitted Radial Load	[N]	*7	46000	49000	53000	55000
Permitted Axial Load	[N]	*8	34000	36000	38000	40000
Maximum Radial Load	[N]	*9	64000			
Maximum Axial Load	[N]	*10	48000			
Maximum Tilting Moment	[Nm]	*11	11000			
Moment of Inertia ($\leq \varnothing 38$)	[kgcm ²]	--	-	-	-	-
Moment of Inertia ($\leq \varnothing 48$)	[kgcm ²]	--	58	47	45	53
Efficiency	[%]	*12	90			
Torsional Rigidity	[Nm/arcmin]	*13	840			
Maximum Torsional Backlash	[Arc-min]	*14	≤ 3			
Noise Level	dB [A]	--	≤ 62			
Protection Class	--	*15	IP54 (IP65)			
Ambient Temperature	[°C]	--	0 - 40			
Permitted Housing Temperature	[°C]	--	90			
Weight	[kg]	*16	89			

VRT 255 2-Stage Specifications

Frame Size	255						
Ratio	Unit	Note	35	40	50	70	100
Nominal Output Torque	[Nm]	*1	2400	2400	2400	2400	1600
Maximum Output Torque	[Nm]	*2	3700	3700	3700	3700	1800
Emergency Stop Torque	[Nm]	*3	8000	8000	8000	8000	6000
Nominal Input Speed	[rpm]	*4	1000				
Maximum Input Speed	[rpm]	*5	2000				
No Load Running Torque	[Nm]	*6	1.0				
Permitted Radial Load	[N]	*7	59000	61000	64000	64000	64000
Permitted Axial Load	[N]	*8	42000	44000	47000	48000	48000
Maximum Radial Load	[N]	*9	64000				
Maximum Axial Load	[N]	*10	48000				
Maximum Tilting Moment	[Nm]	*11	11000				
Moment of Inertia ($\leq \varnothing 38$)	[kgcm ²]	--	-	-	14	13	13
Moment of Inertia ($\leq \varnothing 48$)	[kgcm ²]	--	44	32	32	31	31
Efficiency	[%]	*12	90				
Torsional Rigidity	[Nm/arcmin]	*13	840				
Maximum Torsional Backlash	[Arc-min]	*14	≤ 3				
Noise Level	dB [A]	--	≤ 62				
Protection Class	--	*15	IP54 (IP65)				
Ambient Temperature	[°C]	--	0 - 40				
Permitted Housing Temperature	[°C]	--	90				
Weight	[kg]	*16	89				

*1) At nominal input speed, service life is 20,000 hours

*2) The maximum torque when starting or stopping operation

*3) The maximum torque allowed under a stress situation (Permitted 1,000 times during service life)

*4) The average input speed

*5) The maximum intermittent input speed

*6) Torque at no load applied to the input shaft at nominal input speed

*7) At this load and nominal input speed, service life will be 20,000 hours. (The radial load applied to the output side shaft center)

*8) At this load and nominal input speed, service life will be 20,000 hours. (The axial load applied to the output side bearing)

*9) The maximum radial load that the gearbox can accept

*10) The maximum axial load that the gearbox can accept

*11) The moment is the maximum load at output flange surface

*12) The efficiency at the nominal output torque rating

*13) This does not include lost motion

*14) Contact NIDEC-SHIMPO for the testing conditions and environment

*15) IP65 (wash-down) is available as an option. Contact NIDEC-SHIMPO for more details

*16) The weight may vary slightly between models

VRT 255 2-Stage Dimensions

Input bore size $\leq \phi 48$ mm

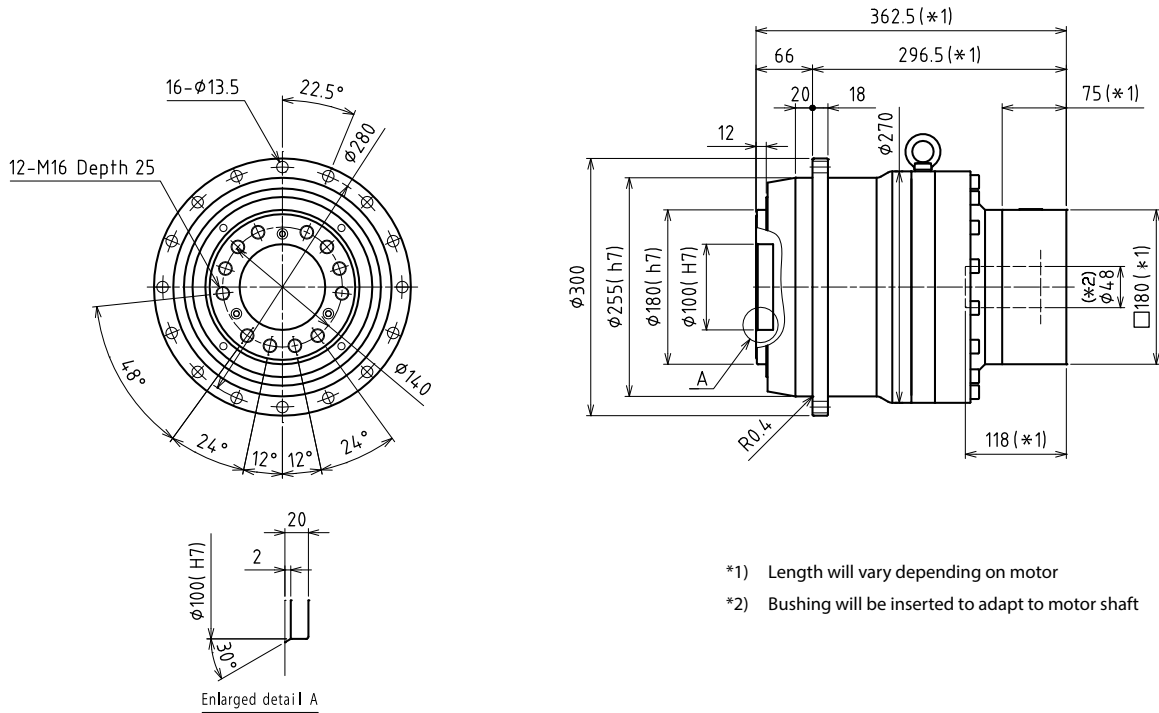

- *1) Length will vary depending on motor
- *2) Bushing will be inserted to adapt to motor shaft

VRT 285 1-Stage Specifications

Frame Size	285					
Ratio	Unit	Note	4	5	7	10
Nominal Output Torque	[Nm]	*1	3300	3300	3300	2200
Maximum Output Torque	[Nm]	*2	5300	5300	5300	3700
Emergency Stop Torque	[Nm]	*3	12000	12000	12000	10000
Nominal Input Speed	[rpm]	*4	1000			
Maximum Input Speed	[rpm]	*5	2000			
No Load Running Torque	[Nm]	*6	2.7			
Permitted Radial Load	[N]	*7	40000	42000	47000	52000
Permitted Axial Load	[N]	*8	34000	36000	40000	45000
Maximum Radial Load	[N]	*9	86000			
Maximum Axial Load	[N]	*10	64000			
Maximum Tilting Moment	[Nm]	*11	18000			
Moment of Inertia ($\leq \varnothing 65$)	[kgcm ²]	--	270	190	130	96
Efficiency	[%]	*12	95			
Torsional Rigidity	[Nm/arcmin]	*13	1200			
Maximum Torsional Backlash	[Arc-min]	*14	≤ 3			
Noise Level	dB [A]	--	≤ 63			
Protection Class	--	*15	IP54 (IP65)			
Ambient Temperature	[°C]	--	0 - 40			
Permitted Housing Temperature	[°C]	--	90			
Weight	[kg]	*16	110			

VRT 285 2-Stage Specifications

Frame Size	285					
Ratio	Unit	Note	16	20	25	28
Nominal Output Torque	[Nm]	*1	2750	3300	3300	3300
Maximum Output Torque	[Nm]	*2	5300	5300	5300	5300
Emergency Stop Torque	[Nm]	*3	12000	12000	12000	12000
Nominal Input Speed	[rpm]	*4	1000			
Maximum Input Speed	[rpm]	*5	2000			
No Load Running Torque	[Nm]	*6	0.6			
Permitted Radial Load	[N]	*7	60000	64000	69000	71000
Permitted Axial Load	[N]	*8	51000	55000	59000	61000
Maximum Radial Load	[N]	*9	86000			
Maximum Axial Load	[N]	*10	64000			
Maximum Tilting Moment	[Nm]	*11	18000			
Moment of Inertia ($\leq \varnothing 38$)	[kgcm ²]	--	-	-	-	-
Moment of Inertia ($\leq \varnothing 48$)	[kgcm ²]	--	63	50	47	55
Efficiency	[%]	*12	90			
Torsional Rigidity	[Nm/arcmin]	*13	1200			
Maximum Torsional Backlash	[Arc-min]	*14	≤ 3			
Noise Level	dB [A]	--	≤ 63			
Protection Class	--	*15	IP54 (IP65)			
Ambient Temperature	[°C]	--	0 - 40			
Permitted Housing Temperature	[°C]	--	90			
Weight	[kg]	*16	120			

VRT 285 2-Stage Specifications

Frame Size	285							
Ratio	Unit	Note	35	40	50	70	100	
Nominal Output Torque	[Nm]	*1	3300	3300	3300	3300	2200	
Maximum Output Torque	[Nm]	*2	5300	5300	5300	5300	2500	
Emergency Stop Torque	[Nm]	*3	12000	12000	12000	12000	10000	
Nominal Input Speed	[rpm]	*4	1000					
Maximum Input Speed	[rpm]	*5	2000					
No Load Running Torque	[Nm]	*6	0.6					
Permitted Radial Load	[N]	*7	76000	79000	85000	86000	86000	
Permitted Axial Load	[N]	*8	64000	64000	64000	64000	64000	
Maximum Radial Load	[N]	*9	86000					
Maximum Axial Load	[N]	*10	64000					
Maximum Tilting Moment	[Nm]	*11	18000					
Moment of Inertia ($\leq \varnothing 38$)	[kgcm ²]	--	-	-	14	14	13	
Moment of Inertia ($\leq \varnothing 48$)	[kgcm ²]	--	45	33	32	31	31	
Efficiency	[%]	*12	90					
Torsional Rigidity	[Nm/arcmin]	*13	1200					
Maximum Torsional Backlash	[Arc-min]	*14	≤ 3					
Noise Level	dB [A]	--	≤ 63					
Protection Class	--	*15	IP54 (IP65)					
Ambient Temperature	[°C]	--	0 - 40					
Permitted Housing Temperature	[°C]	--	90					
Weight	[kg]	*16	120					

*1) At nominal input speed, service life is 20,000 hours

*2) The maximum torque when starting or stopping operation

*3) The maximum torque allowed under a stress situation (Permitted 1,000 times during service life)

*4) The average input speed

*5) The maximum intermittent input speed

*6) Torque at no load applied to the input shaft at nominal input speed

*7) At this load and nominal input speed, service life will be 20,000 hours. (The radial load applied to the output side shaft center)

*8) At this load and nominal input speed, service life will be 20,000 hours. (The axial load applied to the output side bearing)

*9) The maximum radial load that the gearbox can accept

*10) The maximum axial load that the gearbox can accept

*11) The moment is the maximum load at output flange surface

*12) The efficiency at the nominal output torque rating

*13) This does not include lost motion

*14) Contact NIDEC-SHIMPO for the testing conditions and environment

*15) IP65 (wash-down) is available as an option. Contact NIDEC-SHIMPO for more details

*16) The weight may vary slightly between models

VRT SERIES Inline Planetary

VRT 285 1-Stage Dimensions

Input bore size $\cong \phi 65$ mm

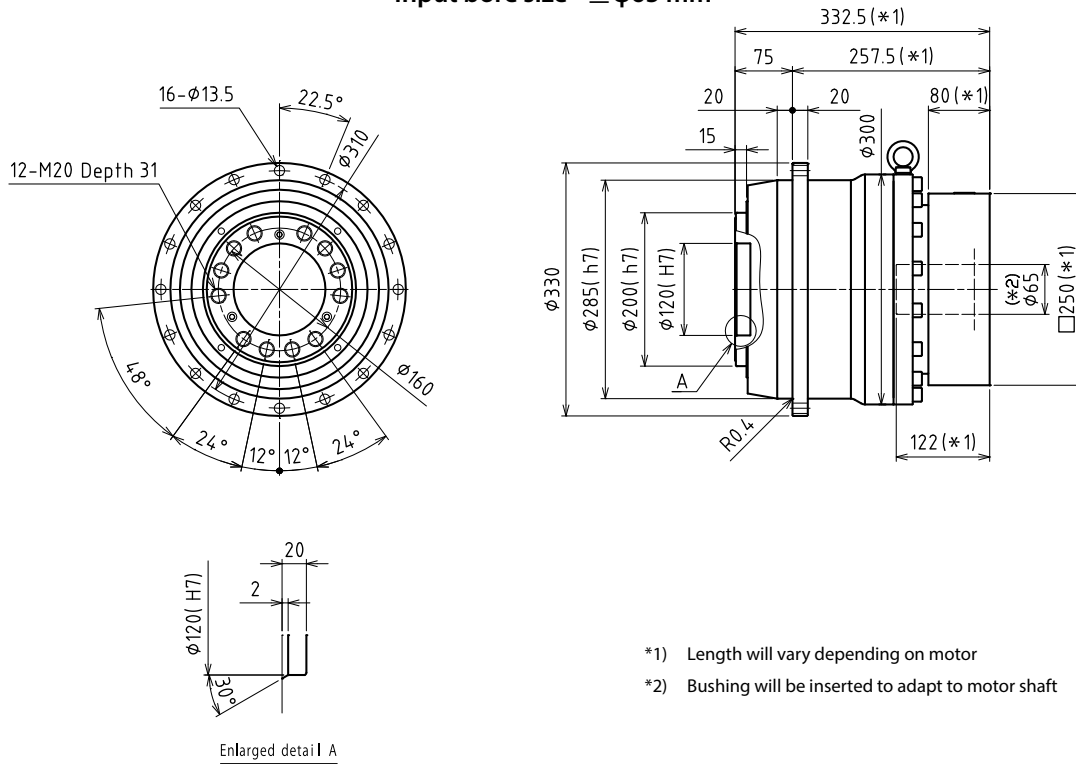

- *1) Length will vary depending on motor
- *2) Bushing will be inserted to adapt to motor shaft

