

QUICK SELECTION / Selezione veloce

input speed (n_1) = 1400 min⁻¹

Output Speed n_2 [min ⁻¹]	Ratio i	Motor power P_{1M} [kW]	Output torque M_{2M} [Nm]	Service factor f.s.	Nominal power P_{1R} [kW]	Nominal torque M_{2R} [Nm]	Available B5 motor flanges		Available B14 motor flanges			Dynamic efficiency RD	Tooth Module [mm]	Ratios code
							B	C	O	P	Q			
							63	71	56	63	71			
5.6	252	0.25	198	1.3	0.33	265	B		B-C	B-C		46	2.7	01
3.9	360	0.18	186	1.4	0.26	265	B		B-C	B-C		42	2.7	02
2.8	504	0.18	241	1.1	0.20	265	B		B-C	B-C		39	2.7	03
1.9	756	0.12	204	1.3	0.16	265	B		B-C	B-C		33	2.7	04
1.4	1008	0.12	256	1.0	0.12	265	B		B-C	B-C		31	2.7	05
1.1	1332	0.12*	265	<0.8	0.10	265	B		B-C	B-C		30	2.7	06
0.8	1656	0.12*	265	<0.8	0.08	265	B		B-C	B-C		28	2.7	07
0.6	2160	0.12*	265	<0.8	0.07	265	B		B-C	B-C		26	2.7	08
0.6	2520	0.12*	265	<0.8	0.06	265	B		B-C	B-C		25	2.7	09

Motor Flanges Available
Flange Motore Disponibili

B) Supplied with Reduction Bushing
Fornito con Bussola di Riduzione

B) Available on Request without reduction bushing
Disponibile a Richiesta senza Bussola di Riduzione

C) Motor Flange Holes Position
Posizione Fori Flangia Motore

* Power higher than the maximum one which can be supported by the gearbox. Select according to the torque M_{2R}
Potenza superiore a quella massima sopportabile dal riduttore. Selezionare in base al momento torcente M_{2R}

EN Unit **64Q** is supplied with synthetic oil, providing "long life" lubrication. For mounting position V5-V6 please contact us. See table 1 for lubrication and recommended quantity. In table 2 please see possible radial loads and axial loads on the gearbox.

I Il riduttore tipo **64Q** viene fornito lubrificato a vita con olio sintetico. Per posizioni V5-V6 contattare il ns. servizio tecnico. Vedi tab.1 per oli e quantità consigliati. In tab.2 sono presenti i carichi radiali e assiali applicabili al riduttore.

D Für die Lebensdauerschmierung ist das Getriebe der Größe **64Q** mit synthetischem Öl befüllt. Bei Einbaulage V5 oder V6 bitten wir um Rücksprache. In Tabelle 1 ist die Schmiermenge und das empfohlene Schmiermittel angegeben. In Tabelle 2 sind die zulässigen Radial- und Axialbelastungen des Getriebes aufgeführt.

F Le réducteur de type **64Q** est fourni lubrifié à vie avec de l'huile synthétique. Concernant les positions V5.V6, contactez notre service d'assistance technique. Voir tableau 1 concernant les huiles et les quantités conseillées. Les charges radiales et axiales applicables au réducteur sont précisées dans le tableau 2.

E El reductor tamaño **64Q** se suministra, lubricado de por vida con aceite sintético. Para las posiciones V5 y V6 contactar con nuestro servicio técnico. Ver tabla 1, para cantidades y aceites recomendados. En la tabla 2, se encuentran las cargas radiales y axiales admitidas por el reductor.

0.30 Lt. **0.09 Lt.**

■ LUBRICATION 64Q Oil
Quantity 0.30/0.09 Lt.

AGIP Telium VSF 320	SHELL Omala S4 WE 320
----------------------------	------------------------------

For all details on lubrication and plugs check our website tab. 1
Per maggiori dettagli su lubrificazione e tappi olio vedi il nostro sito web

■ RADIAL AND AXIAL LOADS

Output shaft
Albero di uscita

n_2 [min ⁻¹]	FA [N]	FR [N]
25	700	3800
15	800	4000

Input shaft
albero in entrata

n_1 [min ⁻¹]	FA [N]	FR [N]
1400	42	210

***Strong axial loads in the DX direction are not allowed.**
Non sono consentiti forti carichi assiali con direzione DX

tab. 2

P64QFB... Basic wormbox
Riduttore base

Gearbox weight
peso riduttore **7.25 kg**

M. flanges	Kit code	øF	A
63B5	K050.4.041	138	74
71B5	K050.4.042	160	71.5
56B14	KC40.4.049	80	71.5
63B14	K050.4.047	90	74
71B14	K050.4.045	105	71.5

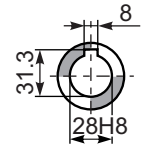
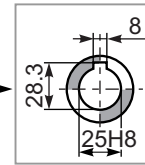
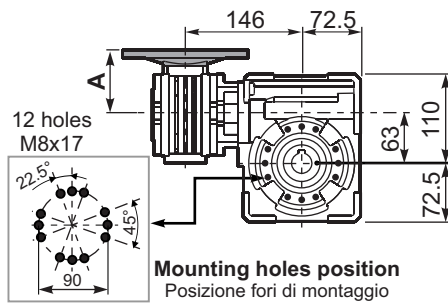
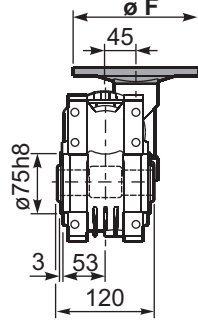

Mounting holes position
Posizione fori di montaggio

Standard
Hollow shaft

On Request
A richiesta

P64QFC... Square flange
Flangia quadrata

P64QF1... Round flange
Flangia rotonda

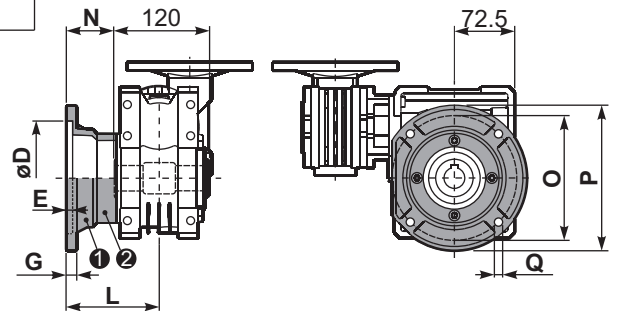
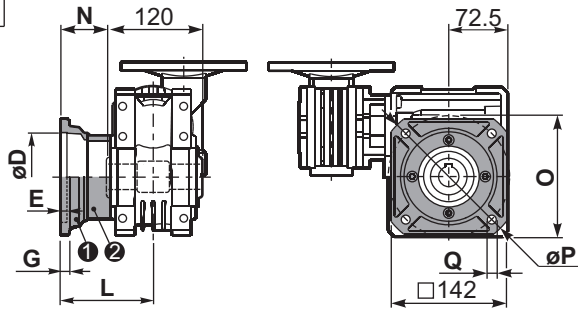

type B	øD	E	G	L	N	O	P	Q	kit code
FC	115 ^{+0.20} / _{+0.15}	6	12	86	26	150	180	11	① KQ63.9.010 ② -
FL	115 ^{+0.20} / _{+0.15}	6	12	116	56	150	180	11	① KQ63.9.010 ② K063.0.200

type S	øD	E	G	L	N	O	P	Q	kit code
F1	130 ^{+0.20} / _{+0.15}	7	13	110	50	165	200	13	① KS070.9.013 ② -
F2	115 ^{+0.20} / _{+0.15}	7	13	124	64	150	175	11	① KS063.9.013 ② -
F3	110 ^{+0.035} / ₀	5	11	90	30	130	160	10	① KS063.9.011 ② -

P64QFB... Feet
Piedi

P64QBR... Reaction arm
Braccio di reazione

kit cod. K063.9.027

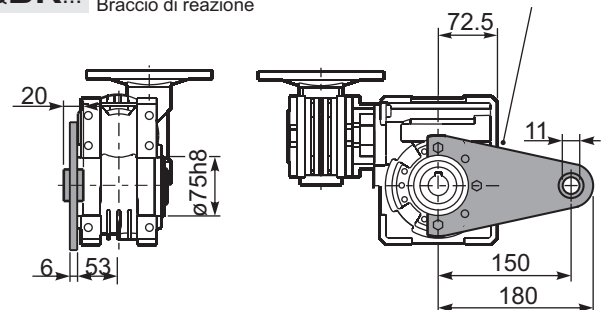
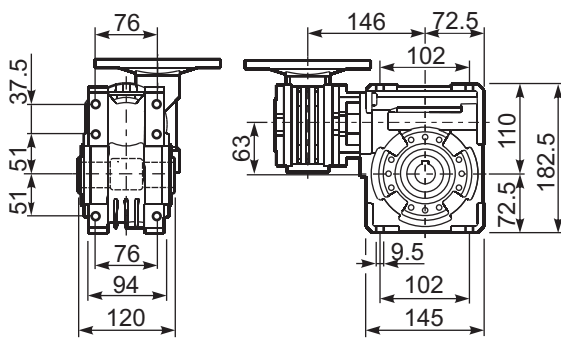

R64QFB... Input shaft
Albero in entrata

P64Q.....S... Single Shaft
Albero lento semplice

P64Q.....D... Double Shaft
Albero lento bisp.

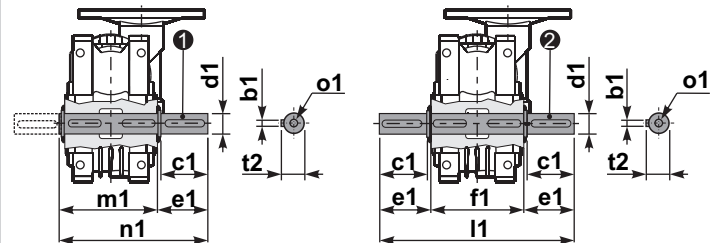
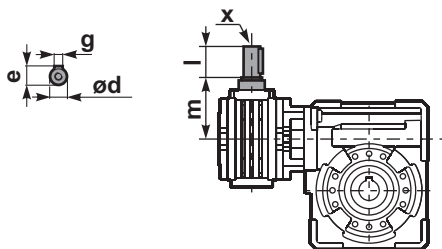

① kit cod. K063.5.028 type B

② kit cod. K063.5.029 type B

	ød	e	g	l	m	x	kit code
type B	11 h6	12.5	4	30	68	-	① K045.5.006 PAM71 ② -
type S	-	-	-	-	-	-	① - ② -

	b1	c1	d1	e1	f1	l1	m1	n1	t2	o1
type B	8	60	25 ^{-0.005} / _{-0.020}	63.2	120	246.4	126.8	190	28	M8x20
type S	-	-	-	-	-	-	-	-	-	-