

QUICK SELECTION / Selezione veloce The dynamic efficiency is **0.94** for all ratios **input speed (n₁) = 1400 min⁻¹**

Output Speed n ₂ [min ⁻¹]	Ratio i	Motor power P _{1M} [kW]	Output torque M _{2M} [Nm]	Service factor f.s.	Nominal power P _{1R} [kW]	Nominal torque M _{2R} [Nm]	Available B5 motor flanges		Available B14 motor flanges			Output Shaft 	Ratios code
							-B	-C	-O	-P	-Q		
							63	71	56	63	71		
27.8	50.35	0.37	119	1.3	0.46	150			C	C		171311	01
25.4	55.22	0.37	131	1.1	0.42	150			C	C		17178	02
23.4	59.92	0.37	142	1.1	0.39	150			C	C		151311	03
21.3	65.72	0.37	156	1.0	0.36	150			C	C		15178	04
19.5	71.78	0.25	115	1.3	0.33	150			C	C		101711	05
17.6	79.44	0.25	127	1.2	0.29	150			C	C		13178	06
15.2	92.08	0.25	147	1.0	0.25	150			C	C		15138	07
14.7	95.03	0.25	152	1.0	0.25	150			C	C		91711	08
11.1	126.55	0.18	155	1.0	0.20	160			C	C		71711	09
10.5	133.15	0.18	163	1.0	0.19	160			C	C		91311	10
9.3	150.18	0.12	119	1.3	0.17	160			C	C		61711	11
7.9	177.30	0.12	140	1.1	0.14	160			C	C		71311	12
6.7	210.42	0.09	133	1.2	0.12	160			C	C		61311	13
6.1	230.79	0.09	146	1.1	0.11	160			C	C		6178	14
5.1	272.47	0.06	113	1.4	0.09	160			C	C		7138	15
4.3	323.37	0.06	134	1.2	0.08	160			C	C		6138	16

Motor Flanges Available Flange Motore Disponibili B) Supplied with Reduction Bushing Fornito con Bussola di Riduzione B) Available on Request without reduction bushing Disponibile a Richiesta senza Bussola di Riduzione C) Motor Flange Holes Position Posizione Fori Flangia Motore

EN Unit **X43A** is supplied with synthetic oil for lifetime lubrication, no maintenance is necessary. See table 1 for lubrication and recommended quantity. In table 2 please see possible radial loads and axial loads on the gearbox.

I Il riduttore **X43A** viene fornito completo di olio sintetico per la lubrificazione permanente e non necessita di alcuna manutenzione. Vedi tab.1 per oli e quantità consigliati. In tab.2 sono presenti i carichi radiali e assiali applicabili al riduttore.

D Das Getriebe **X43A** ist mit synthetischem Öl gefüllt und ist lebensdauergeschmiert. In Tabelle 1 ist die Schmiermenge und das empfohlene Schmiermittel angegeben. In Tabelle 2 sind die zulässigen Radial- und Axialbelastungen des Getriebes aufgeführt.

F Le réducteur **X43A** est fourni complet avec de l'huile synthétique pour la lubrification permanente et ne nécessite aucun entretien. Voir tableau 1 concernant les huiles et les quantités conseillées. Les charges radiales et axiales applicables au réducteur sont précisées dans le tableau 2.

E El reductor tamaño **X43A** se suministra, lubricado de por vida con aceite sintético y no requieren mantenimiento alguna. Ver tabla 1, para cantidades y aceites recomendados. En la tabla 2, se encuentran las cargas radiales y axiales admitidas por el reductor.

Standard supplied	For these mounting position specify in the order or add oil Per queste posizioni specificare in fase d'ordine o aggiungere olio					
B3	B6	B7	B8	V5	V6	V8
0.80 LT	0.80 LT	0.60 LT	0.80 LT	1.20 LT	0.70 LT	Ask
AGIP Telium VSF 320			SHELL Omala S4 WE 320			

For all details on lubrication and plugs check our website **tab. 1**
Per maggiori dettagli su lubrificazione e tappi olio vedi il nostro sito web

RADIAL AND AXIAL LOADS

Output shaft

Albero di uscita

$$F_{eq} = F_R \cdot \frac{54}{X+28}$$

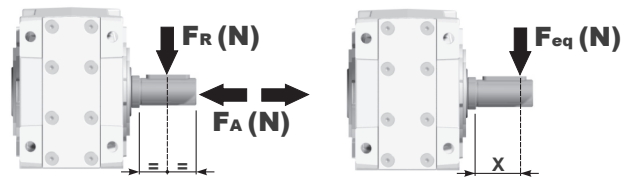

n ₂ [min ⁻¹]	FA	FR	n ₂ [min ⁻¹]	FA	FR	n ₂ [min ⁻¹]	FA	FR
250	500	2500	75	800	4000	15	960	4800
150	600	3000	50	960	4800			
100	700	3500	25	960	4800			

FR On request taper roller bearings to increase radial loads.
A richiesta cuscinetti a rulli conici per aumentare i carichi radiali.

Input shaft

albero in entrata

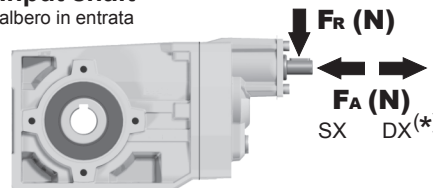

n ₁ [min ⁻¹]	FA [N]	FR [N]
1400	140	700
900	160	800
500	190	950

*Strong axial loads in the DX direction are not allowed.
Non sono consentiti forti carichi assiali con direzione DX

PX43AC... Basic Gearbox
Riduttore base

Gearbox weight
peso riduttore **7.93 kg**

M. flanges	Kit code	øF	A
63B5	K050.4.041	138	205
71B5	K050.4.042	160	202.5
56B14	KC40.4.049	80	202.5
63B14	K050.4.047	90	205
71B14	K050.4.045	105	202.5

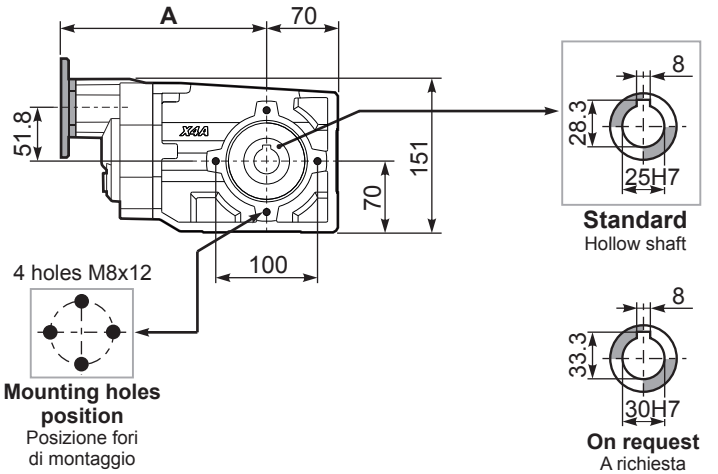
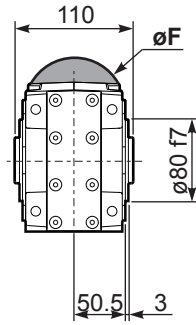

PX43A...FB.. Feet
Piedini

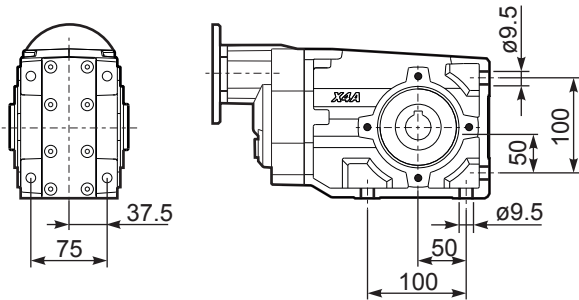

PX43A...-F2.. Output flange
Flangia uscita

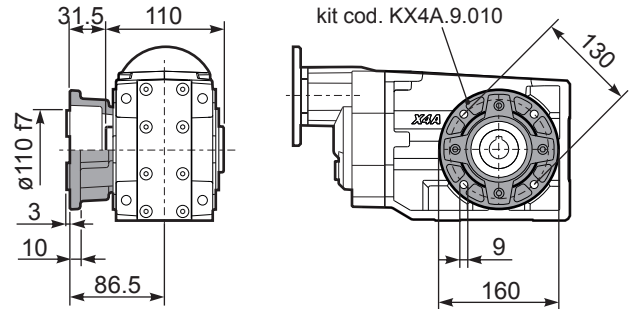

PX43A...-F3.. Output flange
Flangia uscita

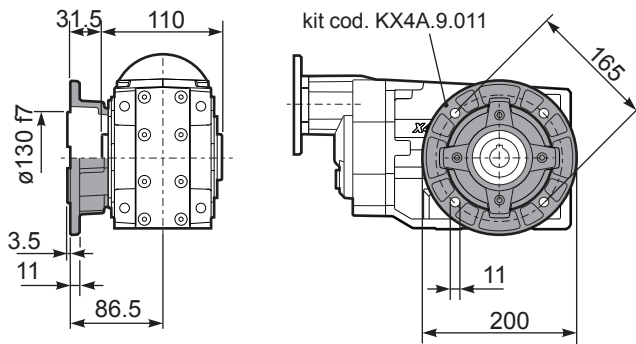

PX43A...-F4.. Output flange
Flangia uscita

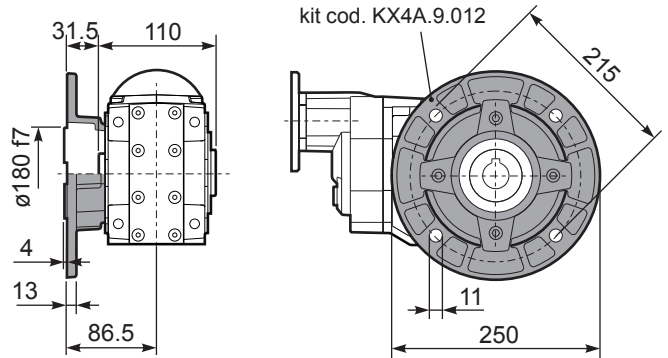

RX43A... Input shaft
Albero in entrata

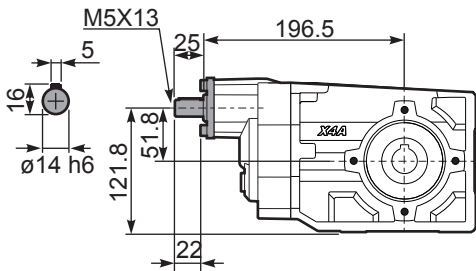

PX43A...BR.. Reaction Arm
Braccio di reazione

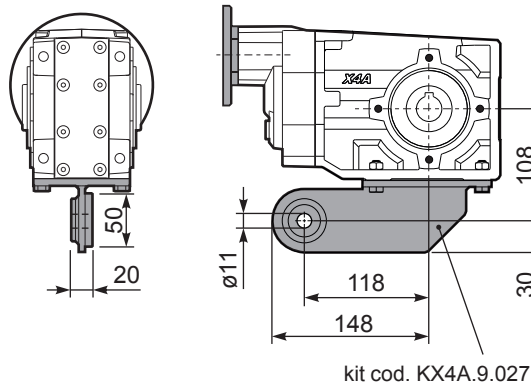

PX43AA.. Single output shaft
Albero semplice in uscita

