

QUICK SELECTION / Selezione veloce

input speed (n_1) = 1400 min⁻¹

Output Speed n_2 [min ⁻¹]	Ratio i	Motor power P_{1M} [kW]	Output torque M_{2M} [Nm]	Service factor f.s.	Nominal power P_{1R} [kW]	Nominal torque M_{2R} [Nm]	B5 motor flanges					B14 motor flanges			Output Shaft 	Ratios code
							-G	-H	-I	-L	CA	-	-	-		
							132	160	180	200	225	-	-	-		
219	6.39	45	1757	1.4	61.0	2500								392914	01	
200	7.00	45	1925	1.4	59.0	2650								392913	02	
164	8.55	45	2350	1.2	51.1	2800								392911	03	
140	10.01	45	2752	1.2	49.8	3200								302914	04	
128	10.97	45	3014	1.1	45.5	3200								302913	05	
105	13.39	37	3025	1.1	39.6	3400								302911	06	
89	15.71	37	3550	1.0	34.7	3500								222914	07	
81	17.21	37	3888	1.0	33.5	3700								222913	08	
67	21.02	30	3877	1.0	29.7	4000								222911	09	
59	23.73	30	4378	0.9	26.9	4100								162914	10	
54	25.99	22	3523	1.2	25.8	4300								162913	11	
50	27.93	22	3786	1.1	24.0	4300								142914	12	
45.8	30.59	22	4146	1.1	22.9	4500								142913	13	
44.1	31.74	22	4302	1.0	22.1	4500								162911	14	
37.5	37.36	18.5	4255	1.1	18.8	4500								142911	15	
33.8	41.37	18.5	4712	1.0	17.0	4500								102914	16	
30.9	45.31	15	4179	1.1	15.5	4500								102913	17	
25.3	55.33	11	3750	1.2	12.7	4500								102911	18	

The dynamic efficiency is **0.94** for all ratios

Motor Flanges Available
Flange Motore Disponibili

B) Supplied with Reduction Bushing
Fornito con Bussola di Riduzione

B) Available on Request without reduction bushing
Disponibile a Richiesta senza Bussola di Riduzione

C) Motor Flange Holes Position
Posizione Fori Flangia Motore

EN Unit **X113** is supplied without lubricant and equipped with a breather, level and drain plugs. User can add mineral oil keeping existing plugs. Should the user wish to fill it with synthetic oil, it is recommended to replace the existing plugs with a closed plug. See table 1 for lubrication and recommended quantity. In table 2 please see possible radial loads and axial loads on the gearbox.

I Il riduttore tipo **X113** è fornito privo di lubrificazione con tappi di sfiato, livello e scarico olio. L'utente può immettere olio minerale mantenendo i tappi esistenti. Se immetterà olio sintetico, dovrà sostituire i tappi esistenti con altri tipo chiuso. Tab.1 per oli e quantità consigliati. Tab.2 carichi radiali e assiali applicabili al riduttore.

D Das Getriebe der Baugröße **X113** wird ohne Schmiermittel geliefert. Es ist jedoch mit Einfüllschraube, Überdruckventil und Ablassschraube ausgerüstet. Das benötigte mineralische Öl kann über die Einfüllschraube eingefüllt werden. Sollte synthetisches Öl bevorzugt werden, so ist sind das eingebaute Überdruckventil durch eine geschlossenen Schraube zu ersetzen. In Tabelle 1 ist die Schmiermenge und das empfohlene Schmiermittel angegeben. In Tabelle 2 sind die zulässigen Radial - und Axialbelastungen des Getriebes aufgeführt.

F Le réducteur de type **X113** est fourni sans lubrification et avec un bouchon de remplissage, de niveau et d'évacuation de l'huile. L'utilisateur peut y verser de l'huile minérale en conservant les bouchons existants. S'il y versera de l'huile synthétique, il devra substituer les bouchons existants avec d'autres bouchons de type fermé. Voir tableau 1 concernant les huiles et les quantités conseillées. Voir tableau 2 concernant les charges radiales et axiales applicables au réducteur.

E El reductor tamaño **X113** se suministra sin lubricante, provisto de tapones de respiración, nivel y descarga de aceite. El usuario puede utilizar aceite mineral, manteniendo los tapones existentes. Si prefiere utilizar aceite sintético deberá sustituir los tapones existentes por tapones ciegos. La prerreducción se suministra con tapones ciegos, lubricado de por vida con aceite sintético. Ver tabla 1, para cantidades y aceites recomendados. En la tabla 2, se encuentran las cargas radiales y axiales admitidas por el reductor.

Standard supplied	For these mounting position specify in the order or add oil Per queste posizioni specificare in fase d'ordine o aggiungere olio					
13.50 LT	8.00 LT	15.50 LT	14.50 LT	22.00 LT	13.00 LT	Ask
AGIP Blasias 460						

For all details on lubrication and plugs check our website **tab. 1**
Per maggiori dettagli su lubrificazione e tappi olio vedi il nostro sito web

RADIAL AND AXIAL LOADS

Output shaft
Albero di uscita

$F_{eq} = FR \cdot \frac{325.5}{X+255.5}$

n_2	FA	FR	n_2	FA	FR	n_2	FA	FR
300	2100	10500	140	3100	15500	70	4200	21000
250	2600	13000	120	3240	16200	40	5600	28000
200	3000	15000	85	3600	18000	15	8000	40000

Input shaft
Albero in entrata

n_1	FA	FR
1400	1120	5600
900	1220	6100
500	1300	6500

tab. 2

PX113C... Basic Gearbox
Riduttore base

Gearbox weight **170 kg**
peso riduttore

M. flanges	Kit code	øF	A
132B5	KC1109052	300	449.5
160B5	KC1109053	350	474.5
180B5	KC1109053_B	350	474.5
200B5	KC1109054	400	474.5
225B5	KC1109055	450	501.5

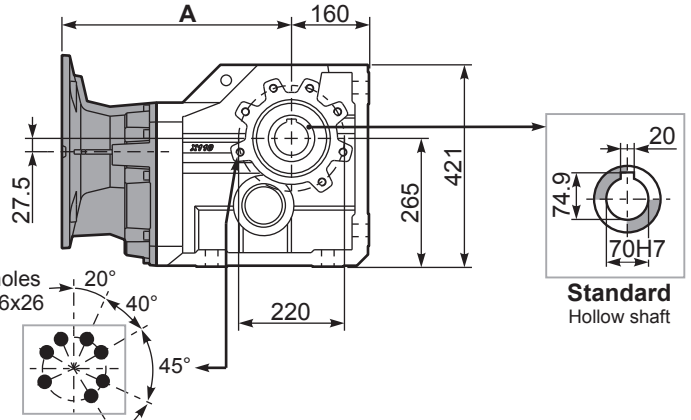
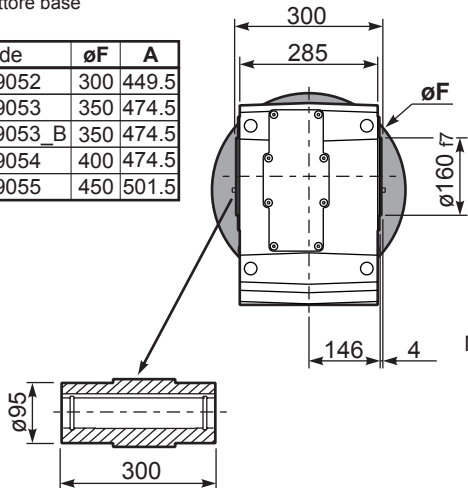
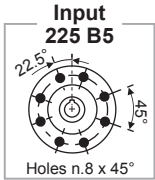

Mounting holes position
Posizione fori di montaggio

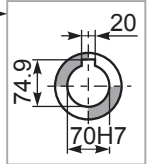
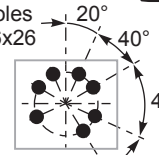

PX113...FB.. Feet
Piedini

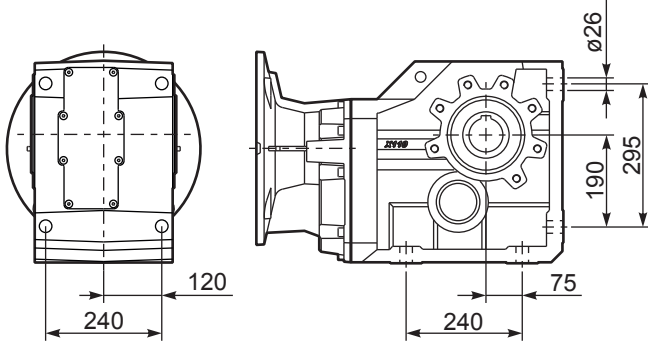

PX113...-F7.. Output flange
Flangia uscita

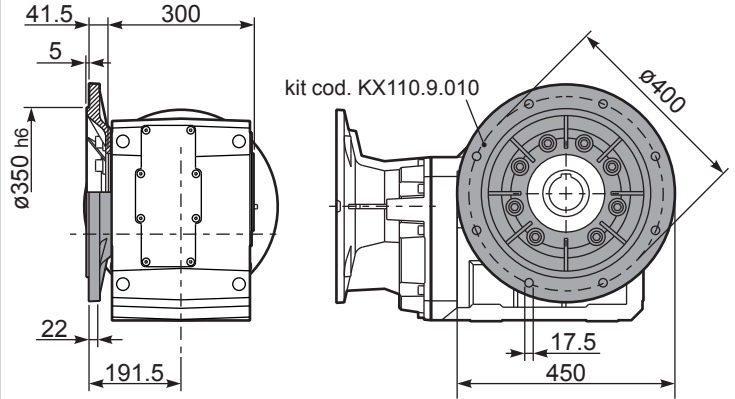

PX113...BR.. Reaction Arm
Braccio di reazione

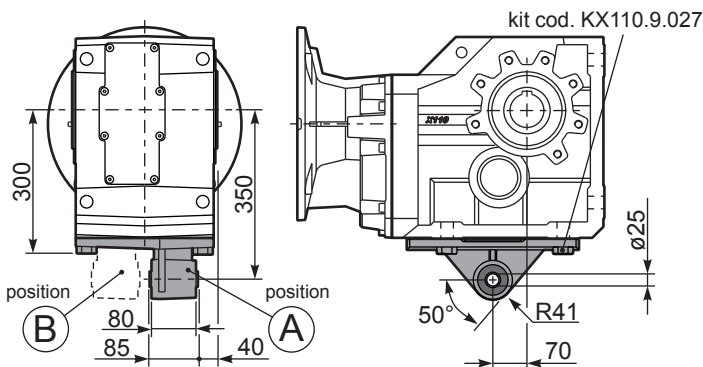

RX113... Input shaft
Albero in entrata

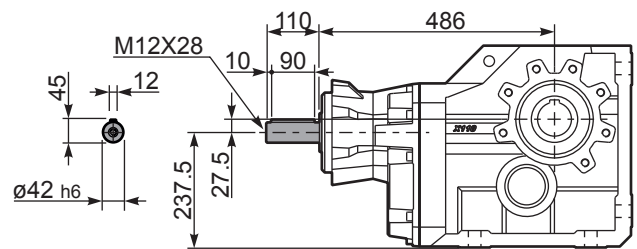

PX113A... Single shaft
Albero lento semplice

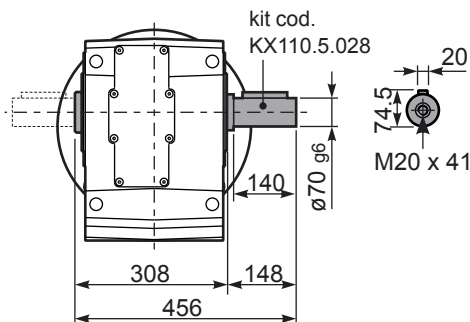

PX113B... Double shaft
Albero lento bisp.

