

Seconda entrata

A richiesta è possibile fornire il riduttore con entrata supplementare.

Second input

On request it is possible to supply the gearbox with an additional input.

Zweiter Antrieb

Auf Wunsch ist das Getriebe mit Zusatzantrieb lieferbar.

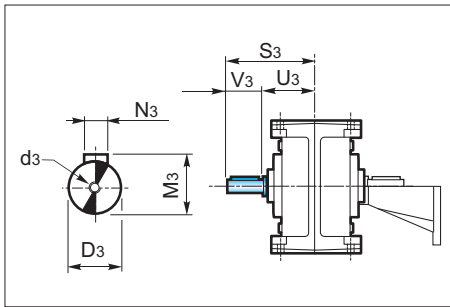

	ZA...											
	80B	100B	125B	160B	180B	200B	80C	100C	125C	160C	180C	200C
D3 _{g6}	14	19	24	28	28	38	14	14	19	24	24	28
d3	M6	M8	M8	M8	M8	M10	M6	M6	M8	M8	M8	M8
N3	5	6	8	8	8	10	5	5	6	8	8	8
M3	16.3	21.8	27.3	31.3	31.3	41.3	16.3	16.3	21.8	27.3	27.3	31.3
S3	95	117.5	140	170	190	230	95	107.5	130	160	180	210
U3	65	77.5	90	110	130	150	65	77.5	90	110	130	150
V3	30	40	50	60	60	80	30	30	40	50	50	60

3.9 Accessori

3.9 Accessories

3.9 Zubehör

Albero lento

Output shaft

Abtriebswelle

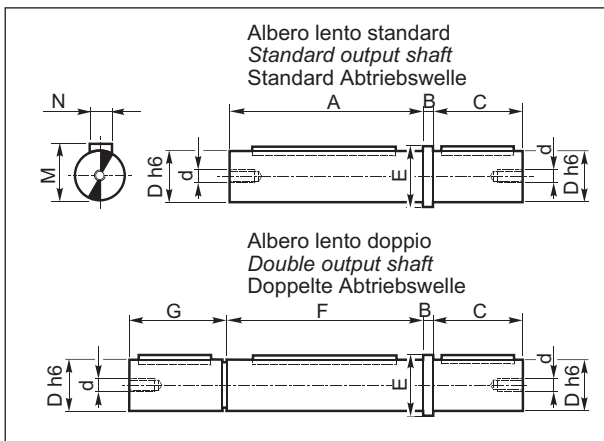

	Z...						
	71A	90A 80B 80C	112A 100B 100C	140A 125B 125C	180A 160B 160C	180B 180C	225A 200B 200C
A	114	129	129	154	154	179	219
B	5	6	6	8	8	10	12
C	50	60	60	80	80	100	125
D _{h6}	24	32	35	42	45	55	70
d	M8	M8	M8	M10	M10	M10	M12
E	30	40	43	50	53	65	80
F	115	130	—	155	—	180	220
G	49	59	—	79	—	99	124
M	27	35	38	45	48.5	59	74.5
N	8	10	10	12	14	16	20

Materiale albero lento: EN 10083 - 1 C40 bonificato
Output shaft material: EN 10083 - 1 C40 tempered
Material der Abtriebswelle: EN 10083 - 1 C40 vergütet

Albero lento cavo con calettatore

Hollow output shaft with shrink disc

Abtriebshohlwelle mit Schrumpfscheibe

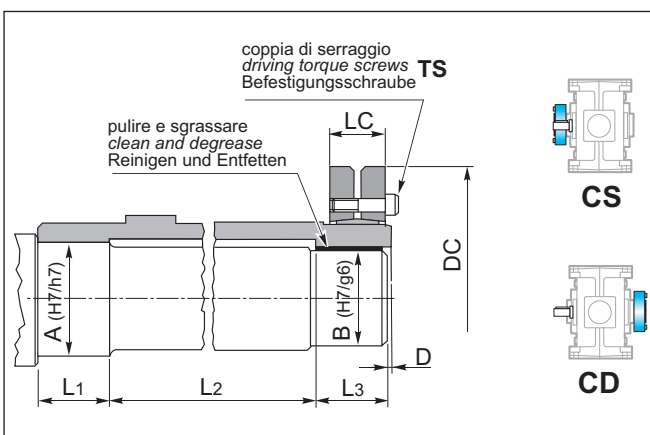

	Z						
	71A	90A 80B 80C	112A 100B 100C	140A 125B 125C	180A 160B 160C	180B 180C	225A 200B 200C
A	27	37	47	57	72	92	102
B	25	35	45	55	70	90	100
D	2	2	2	2	2	3	3
DC	60	80	100	115	155	188	215
LC	22	26	31	31	39	50	54
L ₁	36	39	45	50	60	70	80
L ₂	68	82	100	115	143	175	200
L ₃	36	39	45	50	60	70	80
TS (Nm)	8	12	12	12	36	59	72