

MNHL 50 PAM - MOTORIDUTTORE P.A.M.

MNHL 50 PAM - ARRANGED GEARED MOTORS

MNHL 50 PAM - GETRIEBE ZUM I.E.C. MOTORANBAU

NHL-MNHL

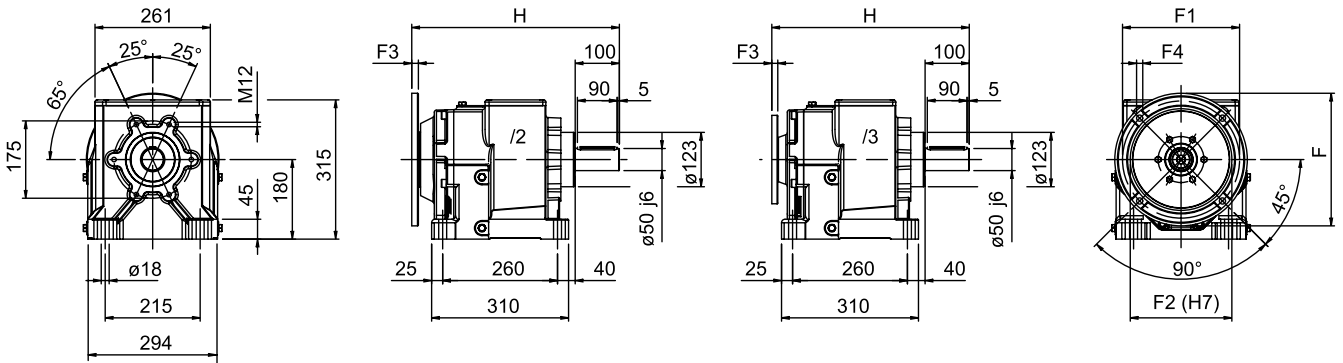

FLANGIA RIPORTATA

MODULAR FLANGE

EINGEBAUTER FLANSCH

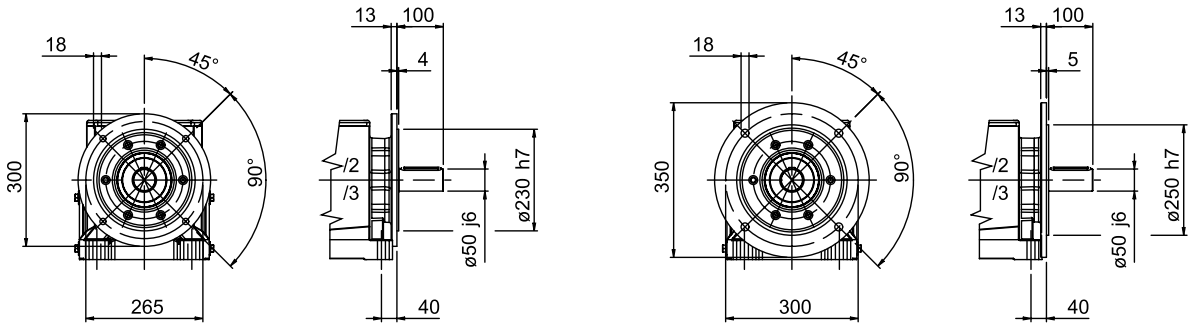

ALBERO USCITA
OUTPUT SHAFT
ABTRIEBSWELLE

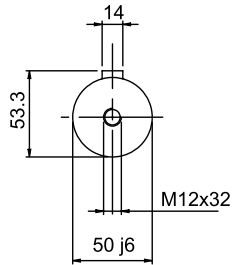

ALBERO ENTRATA
INPUT SHAFT
ANTRIEBSWELLE

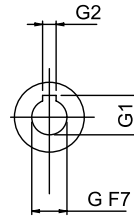

	G	G1	G2	F	F1	F2	F3	F4	H
/2 ... 90 B5	24	27,3	8	200	165	130	15	11,5	467
/2F ... 90 B5									
/2 ... 100-112 B5	28	31,3	8	250	215	180	15	14	470
/2F ... 100-112 B5									
/2 ... 132 B5	38	41,3	10	300	265	230	15	14	470
/2F ... 132 B5									
/2 ... 160 B5	42	45,3	12	350	300	250	19	18	500
/2F ... 160 B5									
/3 ... 63 B5	11	12,8	4	140	115	95	7,5	9	447
/3F ... 63 B5									
/3 ... 71 B5	14	16,3	5	160	130	110	12	9	453
/3F ... 71 B5									
/3 ... 80 B5	19	21,8	6	200	165	130	13,5	11	447
/3F ... 80 B5									
/3 ... 90 B5	24	27,3	8	200	165	130	13,5	11	447
/3F ... 90 B5									
/3 ... 100-112 B5	28	31,3	8	250	215	180	16	13	450
/3F ... 100-112 B5									