

MNHL 40 PAM - MOTORIDUTTORE P.A.M.

MNHL 40 PAM - ARRANGED GEARED MOTORS

MNHL 40 PAM - GETRIEBE ZUM I.E.C. MOTORANBAU

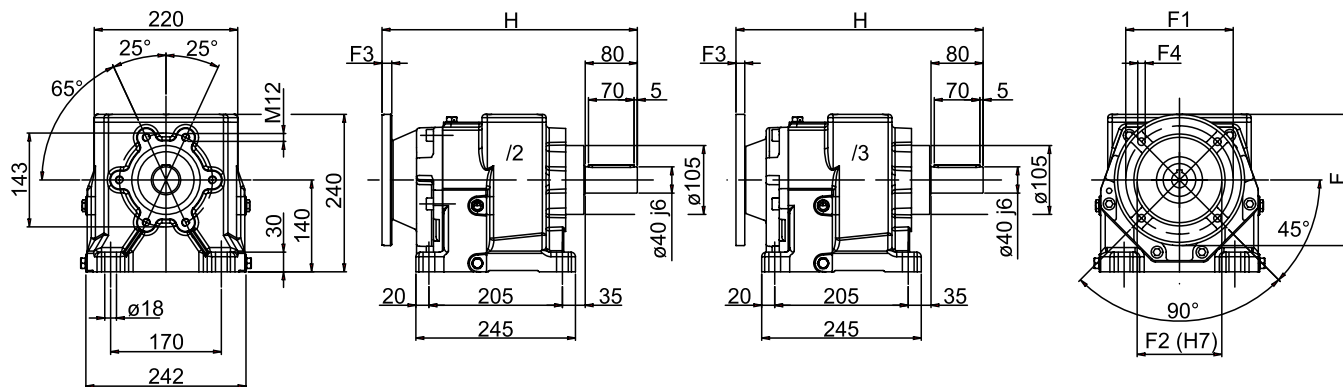

NHL-MNHL

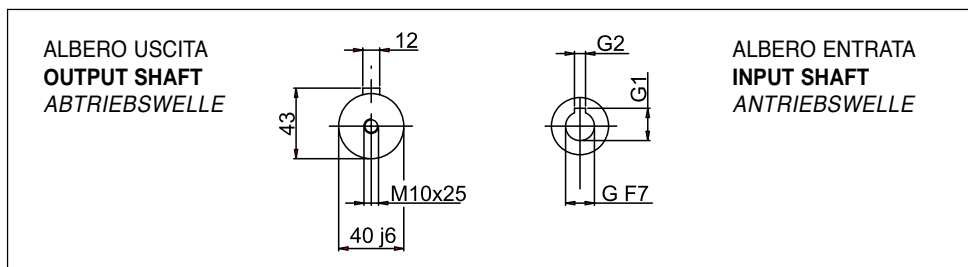
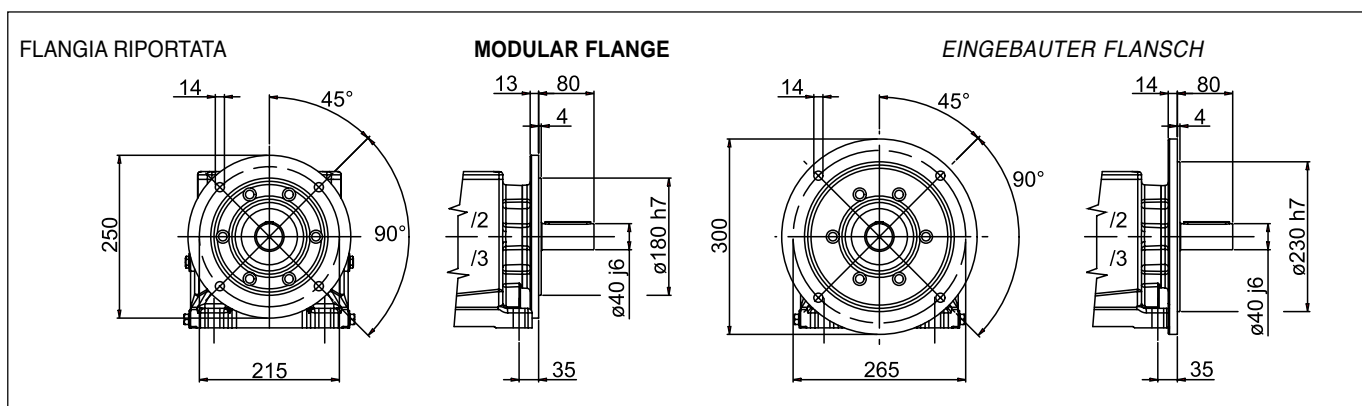

40/2 - 40/3	G	G1	G2	F	F1	F2	F3	F4	H
/2 ... 80 B5	19	21,8	6	200	165	130	15	11,5	392
/2F ... 80 B5									
/2 ... 90 B5	24	27,3	8	200	165	130	15	11,5	395
/2F ... 90 B5									
/2 ... 100-112 B5	28	31,3	8	250	215	180	15	14	395
/2F ... 100-112 B5									
/2 ... 132 B5	38	41,3	10	300	265	230	15	14	425
/2F ... 132 B5									
/3 ... 63 B5	11	12,8	4	140	115	95	12	9	379,5
/3F ... 63 B5									
/3 ... 71 B5	14	16,3	5	160	130	110	10	9	385,5
/3F ... 71 B5									
/3 ... 80 B5	19	21,8	6	200	165	130	11	11	379,5
/3F ... 80 B5									
/3 ... 90 B5	24	27,3	8	200	165	130	11	11	379,5
/3F ... 90 B5									