

MNHL 100 PAM - MOTORIDUTTORE P.A.M.

MNHL 100 PAM - ARRANGED GEARED MOTORS

MNHL 100 PAM - GETRIEBE ZUM I.E.C. MOTORANBAU

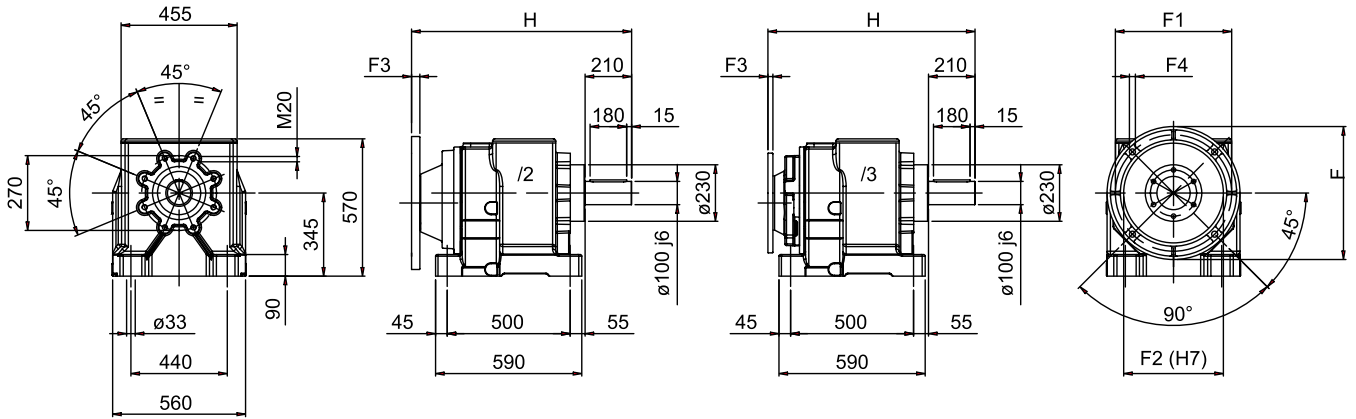

NHL-MNHL

FLANGIA RIPORTATA

MODULAR FLANGE

EINGEBAUTER FLANSCH

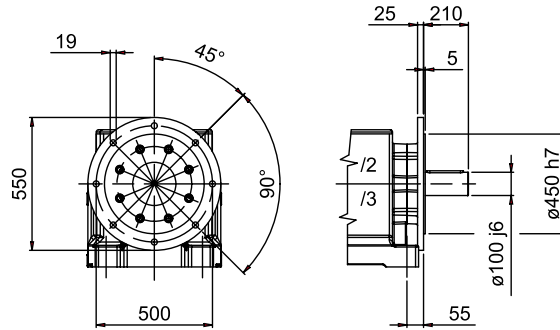

ALBERO USCITA
OUTPUT SHAFT
ABTRIEBSWELLE

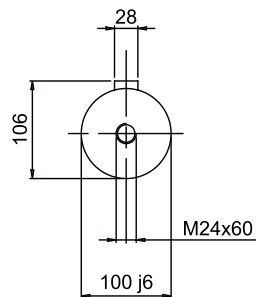

ALBERO ENTRATA
INPUT SHAFT
ANTRIEBSWELLE

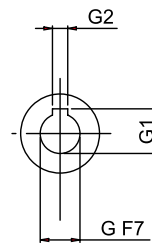

100/2 - 100/3	G	G1	G2	F	F1	F2	F3	F4	H
/2 ... 132 B5	38	41,3	10	300	265	230	25	M12	815
/2F ... 132 B5									
/2 ... 160 B5	42	45,3	12	350	300	250	25	17	865
/2F ... 160 B5									
/2 ... 180 B5	48	51,8	14	350	300	250	25	17	865
/2F ... 180 B5									
/2 ... 200 B5	55	59,3	16	400	350	300	25	18	905
/2F ... 200 B5									
/2 ... 225 B5	60	64,4	18	450	400	350	25	18	905
/2F ... 225 B5									
/2 ... 250 B5	65	69,4	18	550	500	450	25	19*	905
/2F ... 250 B5									
3 ... 132 B5	38	41,3	10	300	265	230	25	M12	779
/3F ... 132 B5									
/3 ... 160 B5	42	45,3	12	350	300	250	25	17	819
/3F ... 160 B5									
/3 ... 180 B5	48	51,8	14	350	300	250	25	17	819
/3F ... 180 B5									
/3 ... 200 B5	55	59,3	16	400	350	300	25	18	859
/3F ... 200 B5									
/3 ... 225 B5	60	64,4	18	450	400	350	25	18	859
/3F ... 225 B5									

* N°8 FORI A 45°

* 8 HOLES AT 45 DEGREES

* 8 LOECHER AUF 45 GRADEN