

Bevel Gearboxes DZA Model H

General data: Gearbox with hollow shaft on the output side. 2 sizes. Ratio either 1 : 1 or 2 : 1 or 3 : 1. Any mounting position possible. The maximum input speed (hollow shaft as input device) for gearing up is 750 min⁻¹ at 2 : 1 and 500 min⁻¹ at 3 : 1.

Housing: Thick-walled, one-piece cast aluminium housing, fully oil-tight and dust-proof.

Gearing: Spiral teeth, hardened.

Shafts/bearing system: Input and output shaft are ground and mounted on ball bearings.

Lubrication/maintenance: Lubricated for life, viscosity ISO VG 150. Gearboxes are maintenance free.

Angular backlash: 15 to 30 angular minutes.

Permiss. operating temperature: -18°C to +80°C.

Ordering details: e.g.: Product No., Type, Size, Ratio

Product No.	Size	Ratio i	Input	Output	Oil	Weight
			Power* kW	Torque* Nm		
410 132 00	2	1:1	2,49	17	0,095	2,0
410 132 02	2	2:1	0,81	11	0,095	2,0
410 132 03	2	3:1	0,39	8	0,095	2,0
410 134 00	3	1:1	5,57	38	0,23	4,8
410 134 02	3	2:1	1,83	25	0,23	4,8
410 134 03	3	3:1	0,88	18	0,23	4,8

*Permiss. max. values for input speed 1,400 min⁻¹ (at the solid shaft) at continuous operation.

Size 2



Size 3



Rotational direction depends on mounting position:

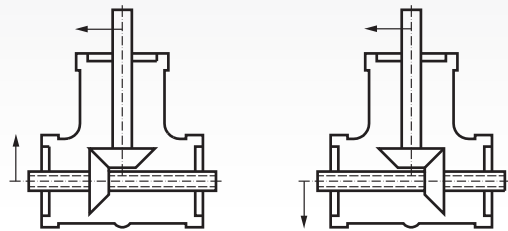

Dimensions Size 2

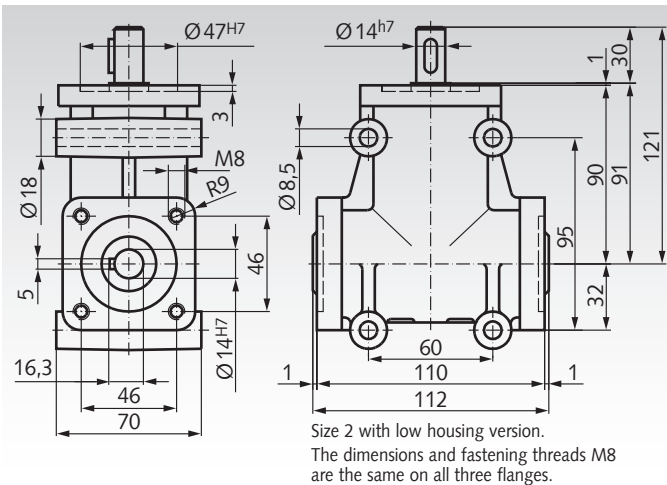

Dimensions Size 3

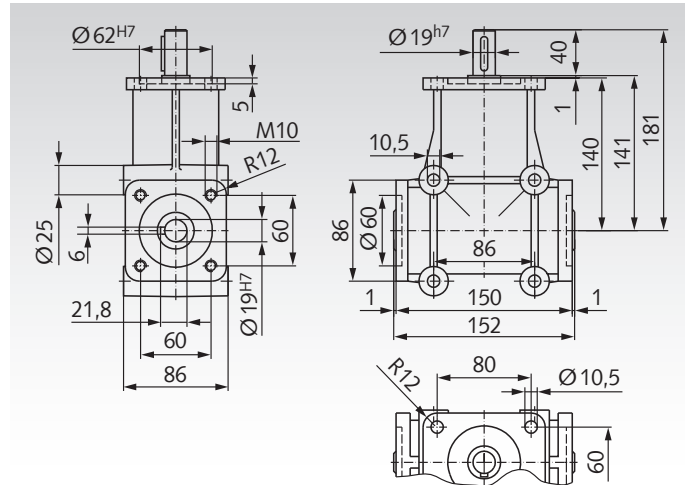

Permissible Radial and Axial Loads

Size	F _R ** N	F _A *** N
2	250	50
3	400	80

** Permiss. radial force at F_A=0.

*** Permiss. axial force at F_R=0.

Operating Factors

Operating hours per day	3	8	12	24
Uniform load	0,8	0,9	1	1,25
Light shocks	0,9	1	1,25	1,5
Strong shocks	1,0	1,5	1,6	1,8