

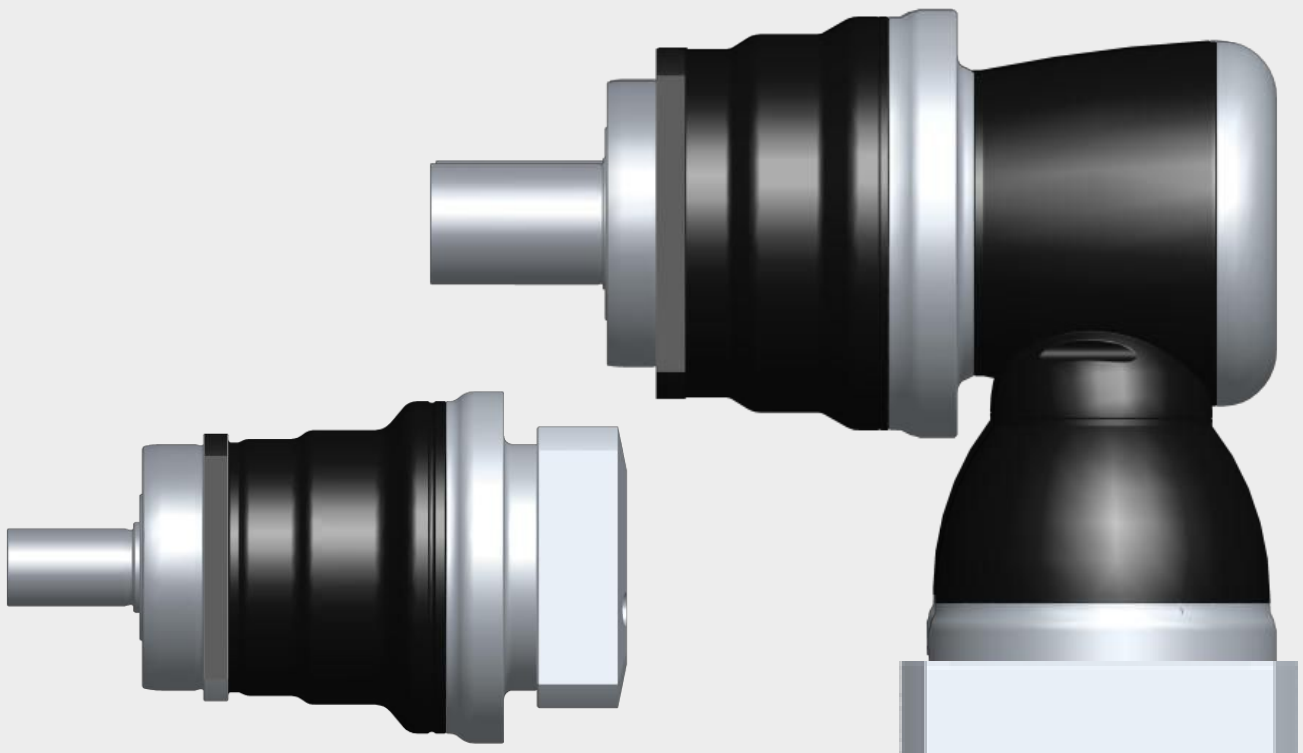

APEX DYNAMICS, INC.

**NEW GENERATION
PLANETARY GEARBOX**

AFH / AFHK Series



Gearbox Series - AFH / AFHK

► Features:

High Torque

Optimized Output Torque & Inertia Moment

High Precision / Low Backlash

Long Service Life

Low Noise

Limited Temperature Rise



Ordering Code - AFH / AFHK Series

AFH075	—	003	—	SI	/	MOTOR
						Motor Type
						Shaft Type
						Ratio
						Gearbox Size

Gearbox Size

AFH 060 / 075 / 100 / 140 / 180 / 210 / 240

AFHK 060 / 075 / 100 / 140 / 180 / 210 / 240

Ratio⁽¹⁾

AFH (1 Stg.) 3 / 4 / 5 / 7 / 10

(2 Stg.) 16 / 20 / 25 / 28 / 35 / 40 / 50 / 70 / 100

AFHK (2 Stg.) 12 / 16 / 20 / 25 / 28 / 35 / 40 / 50 / 70 / 100

AFHKA (3 Stg.) 100 / 125 / 140 / 175 / 200 / 250 / 350 / 400 / 500 / 700 / 1,000

**AFHKB (3 Stg.) 48 / 64 / 84 / 100 / 125 / 140 / 175 / 200 / 250 / 280 / 350 / 400 / 500
700 / 1,000**

AFHK (4 Stg.) 1,225 / 1,400 / 1,750 / 2,000 / 2,800 / 3,500 / 5,000 / 7,000 / 10,000

AFHKC (2 Stg.) 4 / 5 / 7 / 8 / 10

**Shaft Type : S1 = Smooth Output Shaft
S2 = Output Shaft with Key
S3 = DIN5480 Output Shaft
S4 = Hollow Output Shaft**

Motor Type : Manufacturer and Model

(1) Ratio (I = N_{in} / N_{out}).



©2019 by APEX DYNAMICS, INC.

APEX DYNAMICS, INC. reserves modification and copyrights of all technical specifications, illustrations and drawings in this catalog in allowance for continuous products development and advancement. For the newest data and information, please visit <http://www.apexdyna.com/>

Performance - AFH Gearbox

Model No.	Stage	Ratio ⁽¹⁾	AFH 060	AFH 075	AFH 100	AFH 140	AFH 180	AFH 210	AFH 240	
Nominal Output Torque T_{2N} By n_{1N}	1	3	90	155	415	635	1,560	2,465	4,360	
		4	100	205	380	765	1,415	2,190	4,035	
		5	85	185	325	660	1,225	1,905	3,505	
		7	60	135	260	515	980	1,530	2,630	
		10	24	55	160	315	700	1,070	1,810	
	2	16	100	205	400	805	1,485	2,295	4,215	
		20	100	205	400	810	1,495	2,310	4,425	
		25	90	195	345	700	1,295	2,005	3,685	
		28	60	205	405	820	1,510	2,335	4,425	
		35	75	195	350	705	1,310	2,030	3,725	
		40	40	96	220	615	1,260	2,360	4,430	
		50	50	120	275	715	1,325	2,050	3,765	
		70	60	135	300	585	1,095	1,670	2,675	
		100	24	55	160	345	660	1,005	1,700	
Emergency Stop Torque T_{2NOT}	Nm	1,2	3~100	3 times T_{2N}						
Max. Acceleration Torque T_{2B}	Nm	1,2	3~100	1.5 times T_{2N}						
No Load Running Torque ⁽²⁾	Nm	1	3~10	0.3	0.6	1.4	2.5	5	7	11
		2	16~100	0.2	0.3	0.5	1.2	1.7	3	4
Backlash ⁽³⁾	arcmin	1	3~10	≤ 2	≤ 1	≤ 1	≤ 1	≤ 1	≤ 1	≤ 1
		2	16~100	≤ 3	≤ 2	≤ 2	≤ 2	≤ 2	≤ 2	≤ 2
Torsional Rigidity	Nm/arcmin	1,2	3~100	4.6	10	30	55	175	400	550
Nominal Input Speed n_{1N}	rpm	1	3~10	5,000	3,600	3,600	3,000	2,700	2,400	2,100
		2	16~100	5,000	4,600	4,600	4,000	3,700	3,400	3,100
Max. Input Speed n_1	rpm	1	3~10	7,000	6,000	6,000	5,000	4,500	4,000	3,500
		2	16~100	7,000	7,000	7,000	6,000	5,500	5,000	4,500
Max. Radial Load F_{2r} ⁽⁴⁾	N	1,2	3~100	3,000	4,500	6,700	10,000	15,000	22,000	30,000
Max. Axial Load F_{2a} ⁽⁴⁾	N	1,2	3~100	1,500	2,250	3,350	5,000	7,500	11,000	15,000
Max. Tilting Moment M_{2K} ⁽⁴⁾	Nm	1,2	3~100	160	270	550	1,050	1,740	3,350	5,420
Operating Temp.	°C	1,2	3~100	-10° C ~ 90° C						
Degree of Gearbox Protection		1,2	3~100	IP65						
Lubrication		1,2	3~100	Synthetic lubrication grease						
Mounting Position		1,2	3~100	All directions						
Running Noise ⁽⁵⁾	dB(A)	1	3~10	≤ 58	≤ 59	≤ 64	≤ 65	≤ 66	≤ 68	≤ 70
		2	16~100	≤ 58	≤ 59	≤ 60	≤ 63	≤ 66	≤ 68	≤ 70
Efficiency η	%	1	3~10	≥ 97%						
		2	16~100	≥ 94%						

(1) Ratio ($i = N_{in} / N_{out}$).

(2) These values are measured by gearbox with ratio 10 (1-stage) or ratio 100 (2-stage) at 3,000 rpm no loading.

(3) Backlash is measured at 2% of Nominal Output Torque T_{2N} .

(4) Applied to the output shaft center at 100 rpm.

(5) The dB values are measured by gearbox with ratio 10 (1-stage) or ratio 100 (2-stage), no loading at 3,000 RPM or at the respective Nominal Input Speed by bigger model size.

By lower ratio and/or higher RPM, the noise level could be 3 to 5 dB higher.

Inertia - AFH Gearbox

Model No.		AFH 060		AFH 075		AFH 100		AFH 140	
(C3) Ø ^(A)	Stage	1	2	1	2	1	2	1	2
8	kg.cm ²	-	0.1	-	-	-	-	-	-
11		0.21	0.16	-	0.17	-	-	-	-
14		0.24	0.2	0.54	0.21	-	0.42	-	-
19		0.64	-	0.79	0.6	2.51	0.66	-	1.83
24		-	-	4.06	-	4.78	3.94	6.85	4.11
28		-	-	-	-	6.15	-	8.38	5.48
32		-	-	-	-	8.03	-	10.41	7.36
35		-	-	-	-	14.72	-	15.56	14.04
38		-	-	-	-	17.38	-	20.43	16.71
42		-	-	-	-	-	-	25.44	-
48		-	-	-	-	-	-	54.66	-
55		-	-	-	-	-	-	-	-
60		-	-	-	-	-	-	-	-

Model No.		AFH 180		AFH 210		AFH 240	
(C3) Ø ^(A)	Stage	1	2	1	2	1	2
8	kg.cm ²	-	-	-	-	-	-
11		-	-	-	-	-	-
14		-	-	-	-	-	-
19		-	-	-	-	-	-
24		-	4.61	-	-	-	-
28		-	6.14	-	-	-	-
32		19.5	8.17	-	10.55	-	-
35		26.71	15.54	39.6	17.75	86.48	20.8
38		29.11	18.19	42.43	20.17	86.48	23.66
42		34.35	23.20	47.65	25.4	92.61	28.88
48		64.13	52.42	77.41	55.18	122.26	58.64
55		97.45	-	111.26	-	156.7	92.48
60		-	-	-	-	180.17	-

(A) Ø = Input shaft diameter.

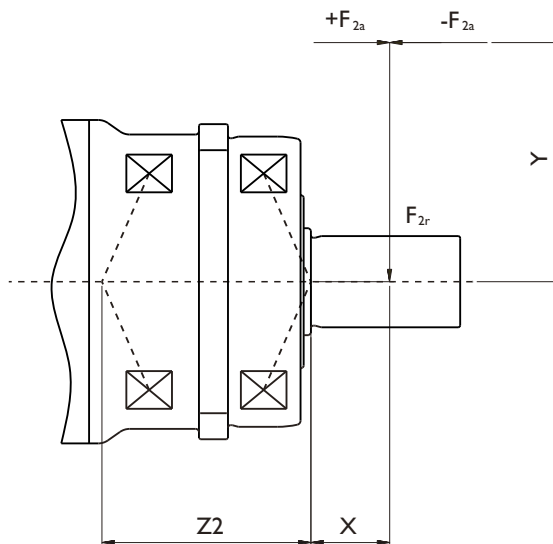

$$\text{Max. Tilting Moment } M_{2K} = \frac{F_{2a} * Y + F_{2r} * (X+Z2)}{1000}$$

M_{2K} : [Nm]
 F_{2a}, F_{2r} : [N]
 $X, Y, Z2$: [mm]

AFH / AFHK	060	075	100	140	180	210	240
Z2 [mm]	41.3	50.1	58.9	72.7	93.7	98.5	112.2

Note : Applied to the output shaft center at 100 rpm.

Dimension - AFH Gearbox

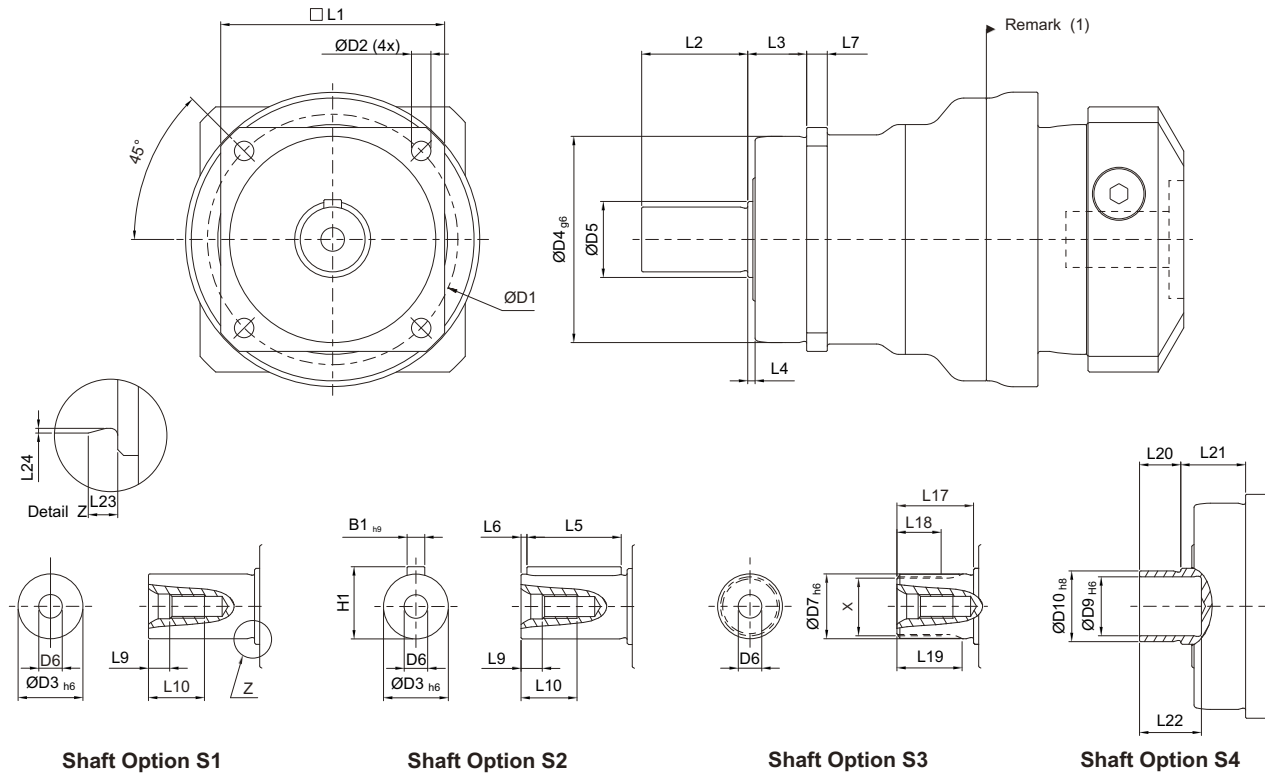

Shaft Option S1

Shaft Option S2

Shaft Option S3

Shaft Option S4

Dimension	AFH 060	AFH 075	AFH 100	AFH 140	AFH 180	AFH 210	AFH 240
D1	68	85	120	165	215	250	290
D2	5.5	7	9	11	13.5	17	17
D3 h6	16	22	32	40	55	75	85
D4 g6	60	70	90	130	160	180	200
D5	18.5	25.8	36.8	55.2	69.2	82.2	92.2
D6	M5 x 0.8P	M8 x 1.25P	M12 x 1.75P	M16 x 2P	M20 x 2.5P	M20 x 2.5P	M20 x 2.5P
D7 h6	16	22	32	40	55	75	85
D9 H6	15	20	30	40	55	-	-
D10 h8	18	24	36	50	68	-	-
L1	62	76	101	141	182	215	245
L2	28	36	58	82	82	105	130
L3	20	20	30	30	30	38	40
L4	2	2.5	3	3	3	3	3
L5	25	32	50	63	70	90	125
L6	2	2	4	5	6	7	3
L7	6	7	10	12	15	17	22
L9	4.8	7.2	10	12	15	15	15
L10	12.5	19	28	36	42	42	42
L17	26	26	26	40	41.5	52	60
L18	15	15	15	20	21.5	28	36
L19	21	22.5	23	33.5	33.5	45	53
L20	12	14	18	22	23	-	-
L21	22	22	32	33	32	-	-
L22	19	21	25	30	30	-	-
L23	2	2.5	2.5	2.5	2.5	2.5	4
L24	0.3	0.4	0.4	0.4	0.4	0.4	0.5
B1 h9	5	6	10	12	16	20	22
H1	18	24.5	35	43	59	79.5	90
X DIN5480	W16 x 0.8 x 30 x 18 x 6m	W22x 1.25 x 30 x 16 x 6m	W32 x 1.25 x 30 x 24 x 6m	W40 x 2 x 30 x 18 x 6m	W55 x 2 x 30 x 26 x 6m	W70 x 2 x 30 x 34 x 6m	W80 x 2 x 30 x 38 x 6m

(1) Dimensions are related to motor interface. Please contact APEX for details.

Shrink Disc Power Lock

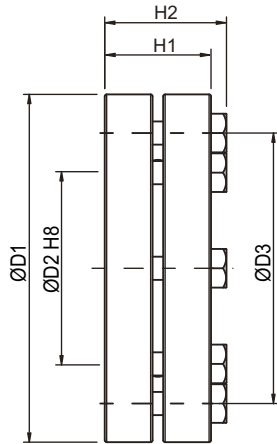

SHRINK DISC POWER LOCK

Diameter	Tolerance
≤ 30	H6 / j6
$> 30 \sim 50$	H6 / h6
$> 50 \sim 80$	H6 / g6

* For surface roughness $Ra \leq 3.2 \mu\text{m}$

Model No. AFH / AFHK	D1	D2	D3	H1	H2	Screw ⁽¹⁾ No x type	TA ⁽²⁾ [Nm]	J [Kg.cm] ²	Order code
060	44	18	30	15	18.5	5 x M5	4	0.4	SSD-18
075	50	24	36	19.5	23	6 x M5	4	0.8	SSD-24
100	72	36	52	23.5	27.5	5 x M6	12	3.9	SSD-36
140	90	50	70	27.5	31.5	8 x M6	12	11.2	SSD-50
180	115	68	86	30.5	34.5	10 x M6	12	30.9	SSD-68

(1) 10.9 Class, DIN 931 (2) Tightening Torque

AFHK Gearbox Structure

AFHK Structure

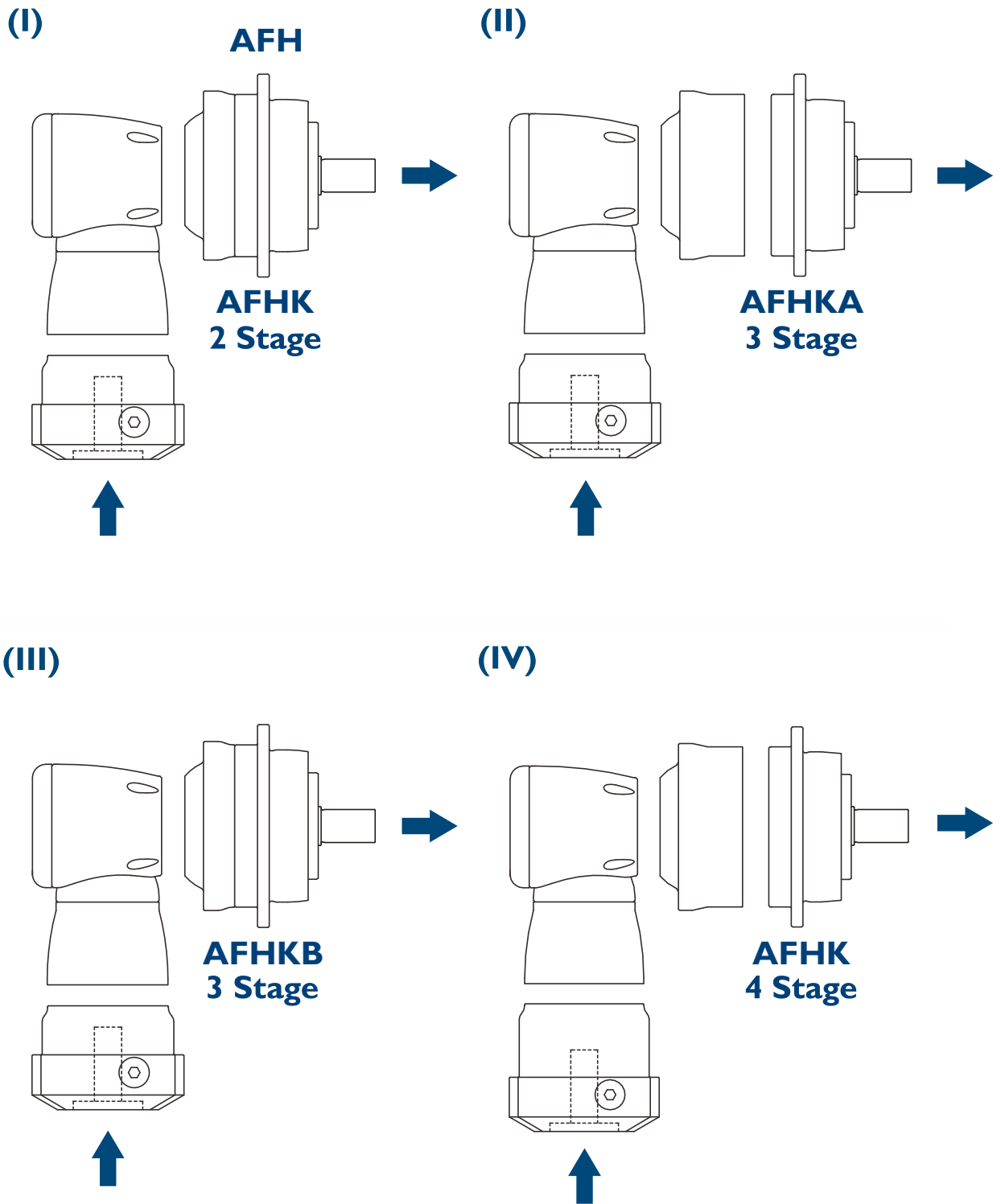

Performance - AFHK (2-Stage) Gearbox

Model No.	Stage	Ratio ⁽¹⁾	AFHK 060	AFHK 075	AFHK 100	AFHK 140	AFHK 180	AFHK 210	AFHK 240	
Nominal Output Torque T_{2N} By n_{1N}	Nm	2	12	100	200	400	805	1,495	1,680	3,280
			16	100	225	405	815	1,510	1,680	3,280
			20	100	230	405	820	1,520	1,780	3,710
			25	95	195	350	710	1,320	1,775	3,735
			28	92	200	400	800	1,535	1,560	3,000
			35	95	200	355	715	1,330	1,950	3,750
			40	72	160	340	680	1,440	1,440	2,400
			50	90	200	360	725	1,345	1,800	3,000
			70	63	135	295	600	1,130	1,710	2,730
100	24	57	160	350	655	1,005	1,685			
Emergency Stop Torque T_{2NOT}	Nm	2	12~100	2 times T_{2N}						
Max. Acceleration Torque T_{2B}	Nm	2	12~100	1.5 times T_{2N}						
No Load Running Torque ⁽²⁾	Nm	2	12~100	1	1.3	2	3.1	6	13	16
Backlash ⁽³⁾	arcmin	2	12~100	≤ 3	≤ 2	≤ 2	≤ 2	≤ 2	≤ 2	≤ 2
Torsional Rigidity	Nm/arcmin	2	12~100	4.6	10	30	55	175	300	510
Nominal Input Speed n_{1N}	rpm	2	12~100	3,000	3,000	2,800	2,700	2,200	2,100	2,000
Max. Input Speed n_{1B}	rpm	2	12~100	6,000	6,000	6,000	4,500	4,500	4,000	3,000
Max. Radial Load F_{2r} ⁽⁴⁾	N	2	12~100	3,000	4,500	6,700	10,000	15,000	22,000	30,000
Max. Axial Load F_{2a} ⁽⁴⁾	N	2	12~100	1,500	2,250	3,350	5,000	7,500	11,000	15,000
Max. Tilting Moment M_{2K} ⁽⁴⁾	Nm	2	12~100	160	270	550	1,050	1,740	3,350	5,420
Operating Temp.	°C	2	12~100	-10° C~ 90° C						
Degree of Gearbox Protection		2	12~100	IP65						
Lubrication		2	12~100	Synthetic lubrication grease						
Mounting Position		2	12~100	All directions						
Running Noise ⁽⁵⁾	dB(A)	2	12~100	≤ 64	≤ 66	≤ 68	≤ 68	≤ 70	≤ 70	≤ 72
Efficiency η	%	2	12~100	≥ 94%						

(1) Ratio ($i = N_{in} / N_{out}$).

(2) These values are measured by gearbox with ratio 100 (2-stage) at 3,000 rpm no loading.

(3) Backlash is measured at 2% of Nominal Output Torque T_{2N} .

(4) Applied to the output shaft center at 100 rpm.

(5) The dB values are measured by gearbox with 100 (2-stage), no loading at 3,000 RPM or at the respective Nominal Input Speed by bigger model size.
By lower ratio and/or higher RPM, the noise level could be 3 to 5 dB higher.

Inertia - AFHK (2-Stage) Gearbox

Model No.	AFHK 060	AFHK 075	AFHK 100	AFHK 140	AFHK 180	AFHK 210	AFHK 240
(C3) \emptyset ^(A)							
8	0.1	-	-	-	-	-	-
11	0.16	0.17	-	-	-	-	-
14	0.2	0.37	0.41	-	-	-	-
19	-	0.6	1.61	1.61	-	-	-
24	-	-	3.9	4.01	5.62	-	-
28	-	-	-	5.53	5.62	-	-
32	-	-	-	7.57	8.11	8.11	-
35	-	-	-	14.95	15.32	15.32	15.68
38	-	-	-	17.58	17.72	17.72	18.52
42	-	-	-	-	22.95	22.95	23.74
48	-	-	-	-	52.74	52.74	53.49
55	-	-	-	-	-	-	87.34

(A) \emptyset = Input shaft diameter.

Dimension - AFHK (2-Stage) Gearbox (Ratio $i = 12 \sim 100$)

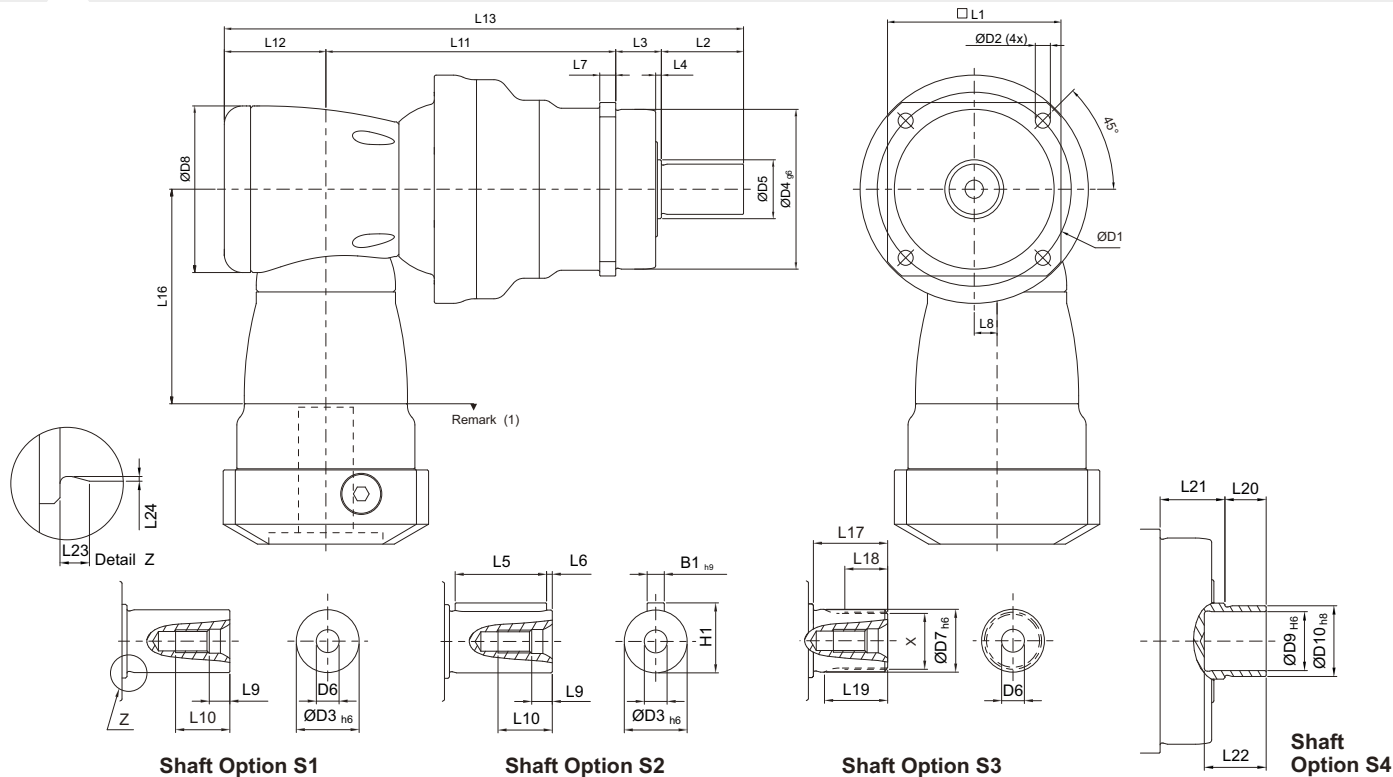

Dimension	AFHK 060	AFHK 075	AFHK 100	AFHK 140	AFHK 180	AFHK 210	AFHK 240
D1	68	85	120	165	215	250	290
D2	5.5	7	9	11	13.5	17	17
D3 h6	16	22	32	40	55	75	85
D4 g6	60	70	90	130	160	180	200
D5	18.5	25.8	36.8	55.2	69.2	82.2	92.2
D6	M5 x 0.8P	M8 x 1.25P	M12 x 1.75P	M16 x 2P	M20 x 2.5P	M20 x 2.5P	M20 x 2.5P
D7 h6	16	22	32	40	55	75	85
D8	73	94	116	163	210	210	255
D9 H6	15	20	30	40	55	-	-
D10 h8	18	24	36	50	68	-	-
L1	62	76	101	141	182	215	245
L2	28	36	58	82	82	105	130
L3	20	20	30	30	30	38	40
L4	2	2.5	3	3	3	3	3
L5	25	32	50	63	70	90	125
L6	2	2	4	5	6	7	3
L7	6	7	10	12	15	17	22
L8	10	13	17	25	31	31	36
L9	4.8	7.2	10	12	15	15	15
L10	12.5	19	28	36	42	42	42
L11	118.5	135.5	152.5	191	248	270	336
L12	44.5	53	68.3	89	115	115	131
L13	211	244.5	308.8	392	475	528	637
L16	94	114.5	129	173.5	228	228	265.5
L17	26	26	26	40	41.5	52	60
L18	15	15	15	20	21.5	28	36
L19	21	22.5	23	33.5	33.5	45	53
L20	12	14	18	22	23	-	-
L21	22	22	32	33	32	-	-
L22	19	21	25	30	30	-	-
L23	2	2.5	2.5	2.5	2.5	2.5	4
L24	0.3	0.4	0.4	0.4	0.4	0.4	0.5
B1 h9	5	6	10	12	16	20	22
H1	18	24.5	35	43	59	79.5	90
X DIN5480	W16 x 0.8 x 30 x 18 x 6m	W22 x 1.25 x 30 x 16 x 6m	W32 x 1.25 x 30 x 24 x 6m	W40 x 2 x 30 x 18 x 6m	W55 x 2 x 30 x 26 x 6m	W70 x 2 x 30 x 34 x 6m	W80 x 2 x 30 x 38 x 6m

(I) Dimensions are related to motor interface. Please contact APEX for details.

Performance - AFHKA (3-Stage) Gearbox

Model No.		Stage	Ratio ⁽¹⁾	AFHKA 240
Nominal Output Torque T_{2N} By n_{1N}	Nm	3	100	4,490
			125	3,900
			140	4,525
			175	3,930
			200	4,565
			250	3,970
			350	4,000
			500	4,035
			700	3,090
			1,000	1,770
Emergency Stop Torque T_{2NOT}	Nm	3	100~1,000	2 times T_{2N}
Max. Acceleration Torque T_{2B}	Nm	3	100~1,000	1.5 times T_{2N}
No Load Running Torque ⁽²⁾	Nm	3	100~1,000	6
Backlash ⁽³⁾	arcmin	3	100~1,000	≤ 2
Torsional Rigidity	Nm/arcmin	3	100~1,000	510
Nominal Input Speed n_{1N}	rpm	3	100~1,000	2,100
Max. Input Speed n_{1B}	rpm	3	100~1,000	4,000
Max. Radial Load F_{2r} ⁽⁴⁾	N	3	100~1,000	30,000
Max. Axial Load F_{2a} ⁽⁴⁾	N	3	100~1,000	15,000
Max. Tilting Moment M_{2K} ⁽⁴⁾	Nm	3	100~1,000	5,420
Operating Temp.	°C	3	100~1,000	-10° C ~ 90° C
Degree of Gearbox Protection		3	100~1,000	IP65
Lubrication		3	100~1,000	Synthetic lubrication grease
Mounting Position		3	100~1,000	All directions
Running Noise ⁽⁵⁾	dB(A)	3	100~1,000	≤ 72
Efficiency η	%	3	100~1,000	$\geq 92\%$

(1) Ratio ($i = N_{in} / N_{out}$).

(2) These values are measured by gearbox with ratio 1,000 (3-stage) at 3,000 rpm no loading.

(3) Backlash is measured at 2% of Nominal Output Torque T_{2N} .

(4) Applied to the output shaft center at 100 rpm.

(5) The dB values are measured by gearbox with 1,000 (3-stage), no loading at 3,000 RPM or at the respective Nominal Input Speed by bigger model size.
By lower ratio and/or higher RPM, the noise level could be 3 to 5 dB higher.

Inertia - AFHKA (3-Stage) Gearbox

Model No.		AFHKA 240
(C3) \emptyset ^(A)		
32	kg.cm ²	8.11
35		15.32
38		17.72
42		22.95
48		52.74

(A) \emptyset = Input shaft diameter.

Dimension - AFHKA (3-Stage) Gearbox (Ratio $i = 100 \sim 1,000$)

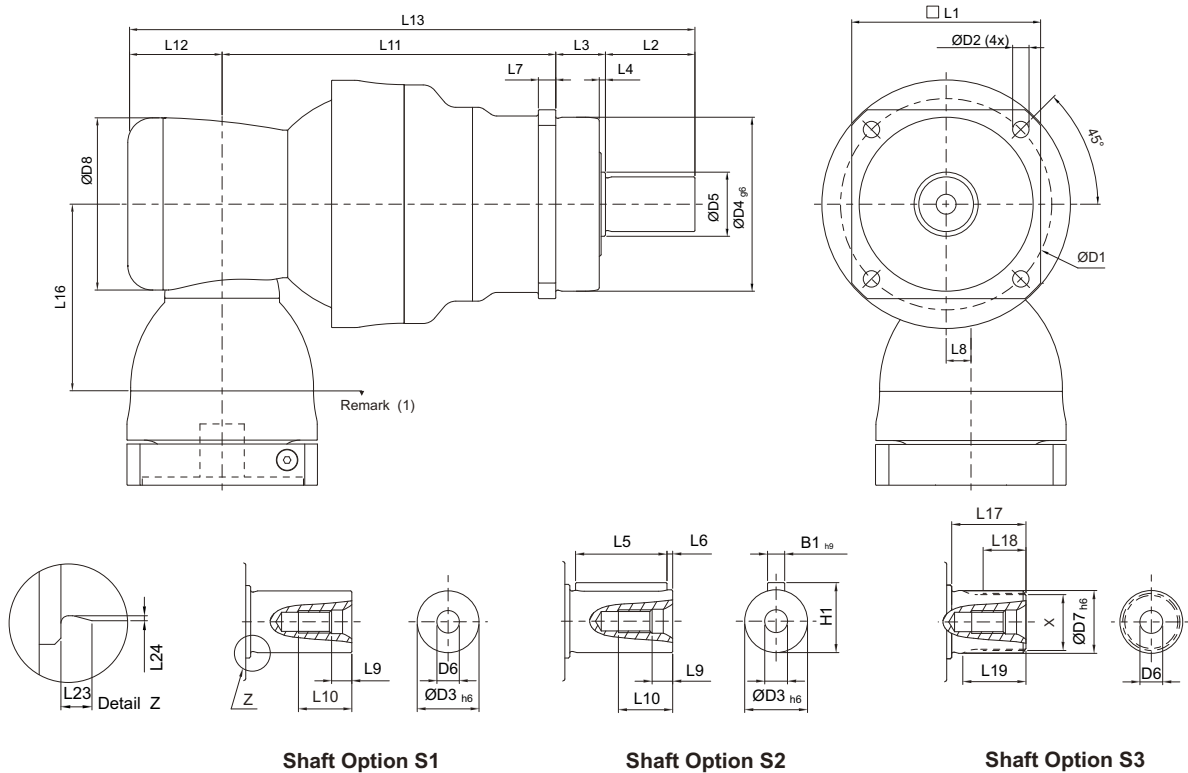

Dimension	AFHKA 240
D1	290
D2	17
D3	h6 85
D4	g6 200
D5	92.2
D6	M20 x 2.5P
D7	h6 85
D8	210
L1	245
L2	130
L3	40
L4	3
L5	125
L6	3
L7	22
L8	31
L9	15
L10	42
L11	378
L12	115
L13	663
L16	228
L17	60
L18	36
L19	53
L23	4
L24	0.5
B1	h9 22
H1	90
X DIN5480	W80 x 2 x 30 x 38 x 6m

(1) Dimensions are related to motor interface. Please contact APEX for details.

Performance - AFHKB (3-Stage) Gearbox

Model No.	Stage	Ratio ⁽¹⁾	AFHKB 075	AFHKB 100	AFHKB 140	AFHKB 180	AFHKB 210	AFHKB 240	
Nominal Output Torque T_{2N} By n_{1N}	Nm	3	48	-	-	-	-	-	3,280
			64	205	415	840	1,545	1,680	3,280
			84	200	420	845	1,555	1,680	-
			100	205	420	845	1,565	2,085	3,830
			125	200	365	730	1,355	2,095	3,850
			140	205	425	845	1,580	2,100	3,860
			175	205	365	740	1,370	2,115	3,885
			200	205	430	845	1,590	2,135	3,900
			250	205	370	745	1,380	2,135	3,920
			280	200	400	800	1,560	1,560	3,000
			350	210	375	755	1,395	1,950	3,750
			400	160	340	680	1,440	1,440	2,400
			500	200	380	760	1,405	1,800	3,000
700	135	325	670	1,240	1,875	3,005			
1,000	55	160	380	660	1,065	1,725			
Emergency Stop Torque T_{2NOT}	Nm	3	48~1,000	2 times T_{2N}					
Max. Acceleration Torque T_{2B}	Nm	3	48~1,000	1.5 times T_{2N}					
No Load Running Torque ⁽²⁾	Nm	3	48~1,000	0.2	0.2	0.3	0.4	1	1.2
Backlash ⁽³⁾	arcmin	3	48~1,000	≤ 2	≤ 2	≤ 2	≤ 2	≤ 2	≤ 2
Torsional Rigidity	Nm/arcmin	3	48~1,000	10	30	55	175	300	510
Nominal Input Speed n_{1N}	rpm	3	48~1,000	5,500	4,600	4,600	4,000	3,700	3,400
Max. Input Speed n_{1B}	rpm	3	48~1,000	7,000	7,000	7,000	6,000	5,500	5,000
Max. Radial Load F_{2r} ⁽⁴⁾	N	3	48~1,000	4,500	6,700	10,000	15,000	22,000	30,000
Max. Axial Load F_{2a} ⁽⁴⁾	N	3	48~1,000	2,250	3,350	5,000	7,500	11,000	15,000
Max. Tilting Moment M_{2K} ⁽⁴⁾	Nm	3	48~1,000	270	550	1,050	1,740	3,350	5,420
Operating Temp.	°C	3	48~1,000	-10° C ~ 90° C					
Degree of Gearbox Protection		3	48~1,000	IP65					
Lubrication		3	48~1,000	Synthetic lubrication grease					
Mounting Position		3	48~1,000	All directions					
Running Noise ⁽⁵⁾	dB(A)	3	48~1,000	≤ 66	≤ 68	≤ 68	≤ 70	≤ 70	≤ 72
Efficiency η	%	3	48~1,000	$\geq 92\%$					

(1) Ratio ($i = N_{in} / N_{out}$).

(2) These values are measured by gearbox with ratio 1,000 (3-stage) at 3,000 rpm no loading.

(3) Backlash is measured at 2% of Nominal Output Torque T_{2N} .

(4) Applied to the output shaft center at 100 rpm.

(5) The dB values are measured by gearbox with 1,000 (3-stage), no loading at 3,000 RPM or at the respective Nominal Input Speed by bigger model size.
By lower ratio and/or higher RPM, the noise level could be 3 to 5 dB higher.

Inertia - AFHKB (3-Stage) Gearbox

Model No.	AFHKB 075	AFHKB 100	AFHKB 140	AFHKB 180	AFHKB 210	AFHKB 240
(C3) $\varnothing^{(A)}$						
8	0.17	-	-	-	-	-
11	0.17	0.42	-	-	-	-
14	0.21	0.42	1.83	-	-	-
19	-	0.66	1.83	4.61	-	-
24	-	-	4.11	4.61	4.61	-
28	-	-	-	6.14	6.14	-
32	-	-	-	8.17	8.17	10.55
35	-	-	-	15.56	15.56	17.76
38	-	-	-	18.19	18.19	20.17
42	-	-	-	-	23.2	25.4
48	-	-	-	-	52.42	55.18

(A) \varnothing = Input shaft diameter.

Dimension - AFHKB (3-Stage) Gearbox (Ratio $i = 48 \sim 1,000$)

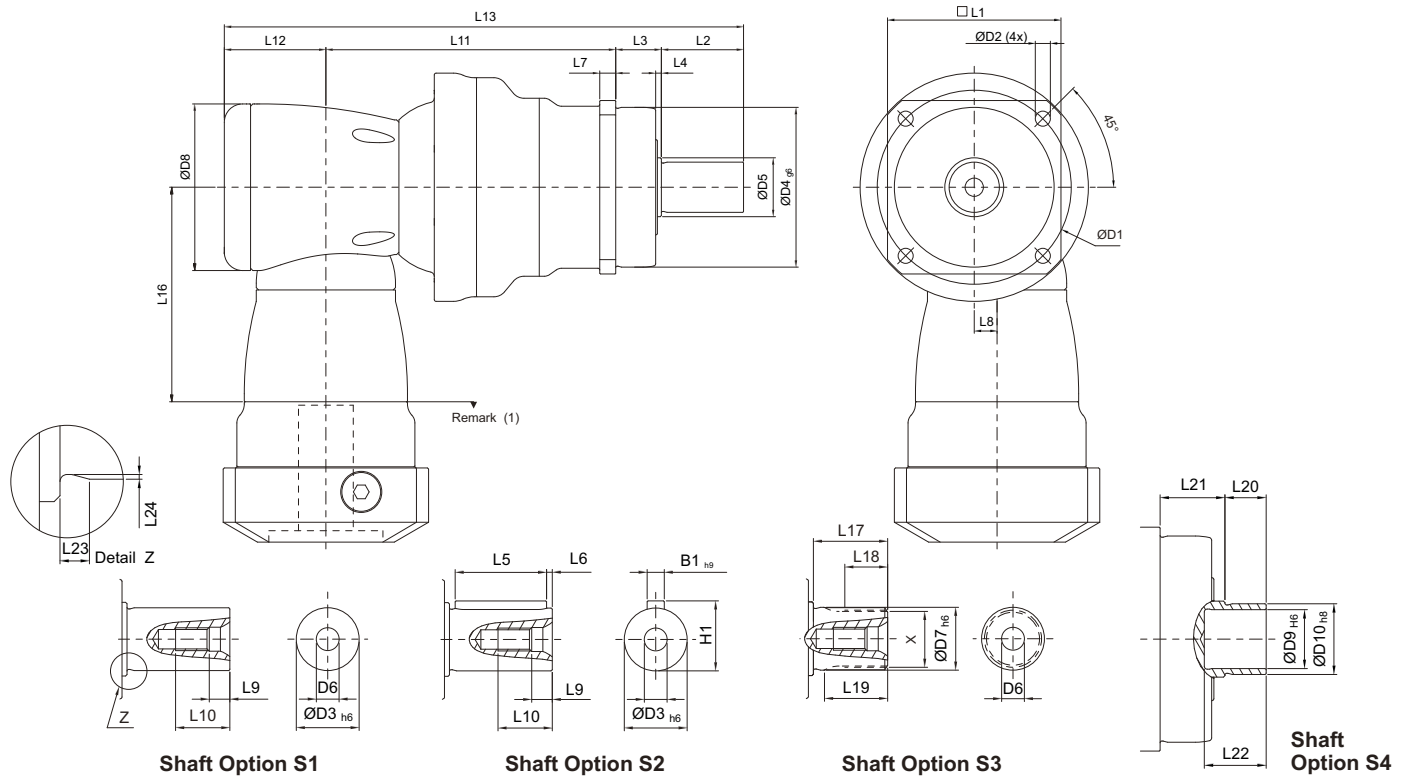

Dimension	AFHKB 075	AFHKB 100	AFHKB 140	AFHKB 180	AFHKB 210	AFHKB 240
D1	85	120	165	215	250	290
D2	7	9	11	13.5	17	17
D3	h6	22	32	40	55	85
D4	g6	70	90	130	160	200
D5	25.8	36.8	55.2	69.2	82.2	92.2
D6	M8 x 1.25P	M12 x 1.75P	M16 x 2P	M20 x 2.5P	M20 x 2.5P	M20 x 2.5P
D7	h6	22	32	40	55	85
D8	94	116	163	210	210	255
D9	H6	20	30	40	-	-
D10	h8	24	36	50	68	-
L1	76	101	141	182	215	245
L2	36	58	82	82	105	130
L3	20	30	30	30	38	40
L4	2.5	3	3	3	3	3
L5	32	50	63	70	90	125
L6	2	4	5	6	7	3
L7	7	10	12	15	17	22
L8	13	17	25	31	31	36
L9	7.2	10	12	15	15	15
L10	19	28	36	42	42	42
L11	135.5	152.5	191	248	270	336
L12	53	68.3	89	115	115	131
L13	244.5	308.8	392	475	528	637
L16	114.5	129	173.5	228	228	265.5
L17	26	26	40	41.5	52	60
L18	15	15	20	21.5	28	36
L19	22.5	23	33.5	33.5	45	53
L20	14	18	22	23	-	-
L21	22	32	33	32	-	-
L22	21	25	30	30	-	-
L23	2.5	2.5	2.5	2.5	2.5	4
L24	0.4	0.4	0.4	0.4	0.4	0.5
B1	h9	6	10	12	16	22
H1	24.5	35	43	59	79.5	90
X DIN5480	W22 x 1.25 x 30 x 16 x 6m	W32 x 1.25 x 30 x 24 x 6m	W40 x 2 x 30 x 18 x 6m	W55 x 2 x 30 x 26 x 6m	W70 x 2 x 30 x 34 x 6m	W80 x 2 x 30 x 38 x 6m

(I) Dimensions are related to motor interface. Please contact APEX for details.

Performance - AFHK (4-Stage) Gearbox

Model No.		Stage	Ratio ⁽¹⁾	AFHK 240
Nominal Output Torque T_{2N} By n_{1N}	Nm	4	1,225	4,070
			1,400	4,725
			1,750	4,100
			2,000	4,765
			2,800	4,165
			3,500	4,180
			5,000	4,285
			7,000	3,445
			10,000	2,240
Emergency Stop Torque T_{2NOT}	Nm	4	1,225~10,000	2 times T_{2N}
Max. Acceleration Torque T_{2B}	Nm	4	1,225~10,000	1.5 times T_{2N}
No Load Running Torque ⁽²⁾	Nm	4	1,225~10,000	0.4
Backlash ⁽³⁾	arcmin	4	1,225~10,000	≤ 2
Torsional Rigidity	Nm/arcmin	4	1,225~10,000	510
Nominal Input Speed n_{1N}	rpm	4	1,225~10,000	3,700
Max. Input Speed n_{1B}	rpm	4	1,225~10,000	5,500
Max. Radial Load F_{2r} ⁽⁴⁾	N	4	1,225~10,000	30,000
Max. Axial Load F_{2a} ⁽⁴⁾	N	4	1,225~10,000	15,000
Max. Tilting Moment M_{2K} ⁽⁴⁾	Nm	4	1,225~10,000	5,420
Operating Temp.	°C	4	1,225~10,000	-10° C~ 90° C
Degree of Gearbox Protection		4	1,225~10,000	IP65
Lubrication		4	1,225~10,000	Synthetic lubrication grease
Mounting Position		4	1,225~10,000	All directions
Running Noise ⁽⁵⁾	dB(A)	4	1,225~10,000	≤ 72
Efficiency η	%	4	1,225~10,000	$\geq 90\%$

(1) Ratio ($i = N_{in} / N_{out}$).

(2) These values are measured by gearbox with ratio 10,000 (4-stage) at 3,000 rpm no loading.

(3) Backlash is measured at 2% of Nominal Output Torque T_{2N} .

(4) Applied to the output shaft center at 100 rpm.

(5) The dB values are measured by gearbox with 10,000 (4-stage), no loading at 3,000 RPM or at the respective Nominal Input Speed by bigger model size.

By lower ratio and/or higher RPM, the noise level could be 3 to 5 dB higher.

Inertia - AFHK (4-Stage) Gearbox

Model No.		AFHK 240
(C3) \varnothing ^(A)		
24	kg.cm ²	4.61
28		6.14
32		8.17
35		15.56
38		18.19

(A) \varnothing = Input shaft diameter.

Dimension - AFHK (4-Stage) Gearbox (Ratio $i = 1,225 \sim 10,000$)

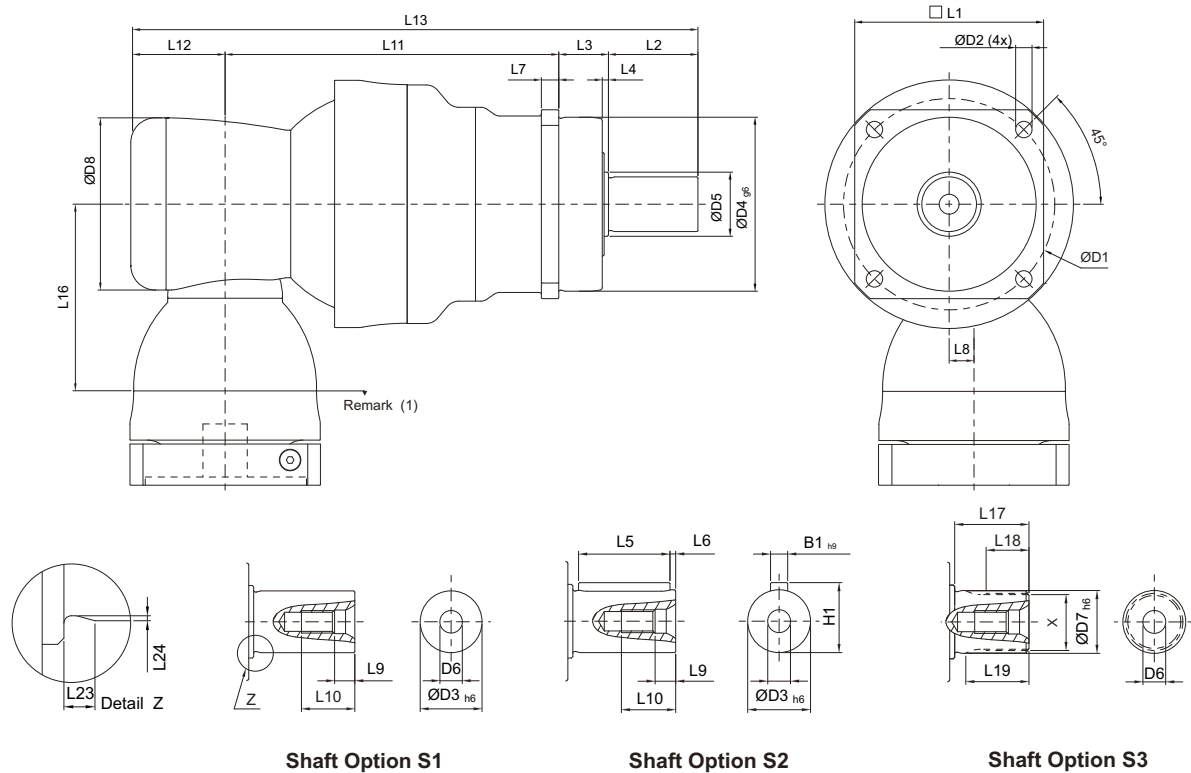

Shaft Option S1

Shaft Option S2

Shaft Option S3

Dimension	AFHK 240
D1	290
D2	17
D3	h6 85
D4	g6 200
D5	92.2
D6	M20 × 2.5P
D7	h6 85
D8	210
L1	245
L2	130
L3	40
L4	3
L5	125
L6	3
L7	22
L8	31
L9	15
L10	42
L11	378
L12	115
L13	663
L16	228
L17	60
L18	36
L19	53
L23	4
L24	0.5
B1	h9 22
H1	90
X DIN5480	W80 × 2 × 30 × 38 × 6m

(1) Dimensions are related to motor interface. Please contact APEX for details.

Performance - AFHKC Gearbox

Model No.		Stage	Ratio ⁽¹⁾	AFHKC 060	AFHKC 075	AFHKC 100	AFHKC 140	AFHKC 180	AFHKC 210	AFHKC 240
Nominal Output Torque T_{2N} By n_{IN}	Nm	2	4	100	205	380	775	1,440	2,240	4,160
			5	85	185	330	670	1,250	1,930	3,610
			7	60	135	260	525	1,000	1,750	2,535
			8	96	205	395	800	1,320	2,300	4,260
			10	90	190	340	690	1,290	2,000	3,700
Emergency Stop Torque T_{2NOT}	Nm	2	4~10	2 times T_{2N}						
Max. Acceleration Torque T_{2B}	Nm	2	4~10	1.5 times T_{2N}						
No Load Running Torque ⁽²⁾	Nm	2	4~10	2	2.5	5.8	12	25	48	95
Backlash ⁽³⁾	arcmin	2	4~10	≤ 3	≤ 2	≤ 2	≤ 2	≤ 2	≤ 2	≤ 2
Torsional Rigidity	Nm/arcmin	2	4~10	4.6	10	30	55	175	300	510
Nominal Input Speed n_{IN}	rpm	2	4~10	5,000	3,600	3,000	2,300	1,800	1,500	1,100
Max. Input Speed n_{IB}	rpm	2	4~10	7,000	6,000	5,500	4,500	3,500	3,000	2,200
Max. Radial Load F_{2r} ⁽⁴⁾	N	2	4~10	3,000	4,500	6,700	10,000	15,000	22,000	30,000
Max. Axial Load F_{2a} ⁽⁴⁾	N	2	4~10	1,500	2,250	3,350	5,000	7,500	11,000	15,000
Max. Tilting Moment M_{2K} ⁽⁴⁾	Nm	2	4~10	160	270	550	1,050	1,740	3,350	5,420
Operating Temp.	°C	2	4~10	-10° C ~ 90° C						
Degree of Gearbox Protection		2	4~10	IP65						
Lubrication		2	4~10	Synthetic lubrication grease						
Mounting Position		2	4~10	All directions						
Running Noise ⁽⁵⁾	dB(A)	2	4~10	≤ 68	≤ 68	≤ 68	≤ 70	≤ 70	≤ 72	≤ 74
Efficiency η	%	2	4~10	$\geq 95\%$						

(1) Ratio ($i = N_{in} / N_{out}$).

(2) These values are measured by gearbox with ratio 10 (2-stage) at 3,000 rpm no loading.

(3) Backlash is measured at 2% of Nominal Output Torque T_{2N} .

(4) Applied to the output shaft center at 100 rpm.

(5) The dB values are measured by gearbox with 10 (2-stage), no loading at 3,000 RPM or at the respective Nominal Input Speed by bigger model size.

By lower ratio and/or higher RPM, the noise level could be 3 to 5 dB higher.

Inertia - AFHKC Gearbox

Model No.		AFHKC 060	AFHKC 075	AFHKC 100	AFHKC 140	AFHKC 180	AFHKC 210	AFHKC 240
(C3) $\emptyset^{(A)}$								
8	kg·cm ²	0.1	-	-	-	-	-	-
11		0.16	0.41	-	-	-	-	-
14		0.20	0.41	-	-	-	-	-
19		0.58	1.61	1.61	-	-	-	-
24		-	3.9	4.01	5.62	-	-	-
28		-	-	5.53	5.62	-	-	-
32		-	-	7.57	8.11	8.11	-	-
35		-	-	14.95	15.32	15.32	15.68	19.37
38		-	-	17.58	17.72	17.72	18.52	19.37
42		-	-	-	22.95	22.95	23.74	25.5
48		-	-	-	52.74	52.74	53.49	55.14
55		-	-	-	-	-	87.34	89.59
60		-	-	-	-	-	-	113.06

(A) \emptyset = Input shaft diameter.

Dimension - AFHKC Gearbox (Ratio i = 4~10)

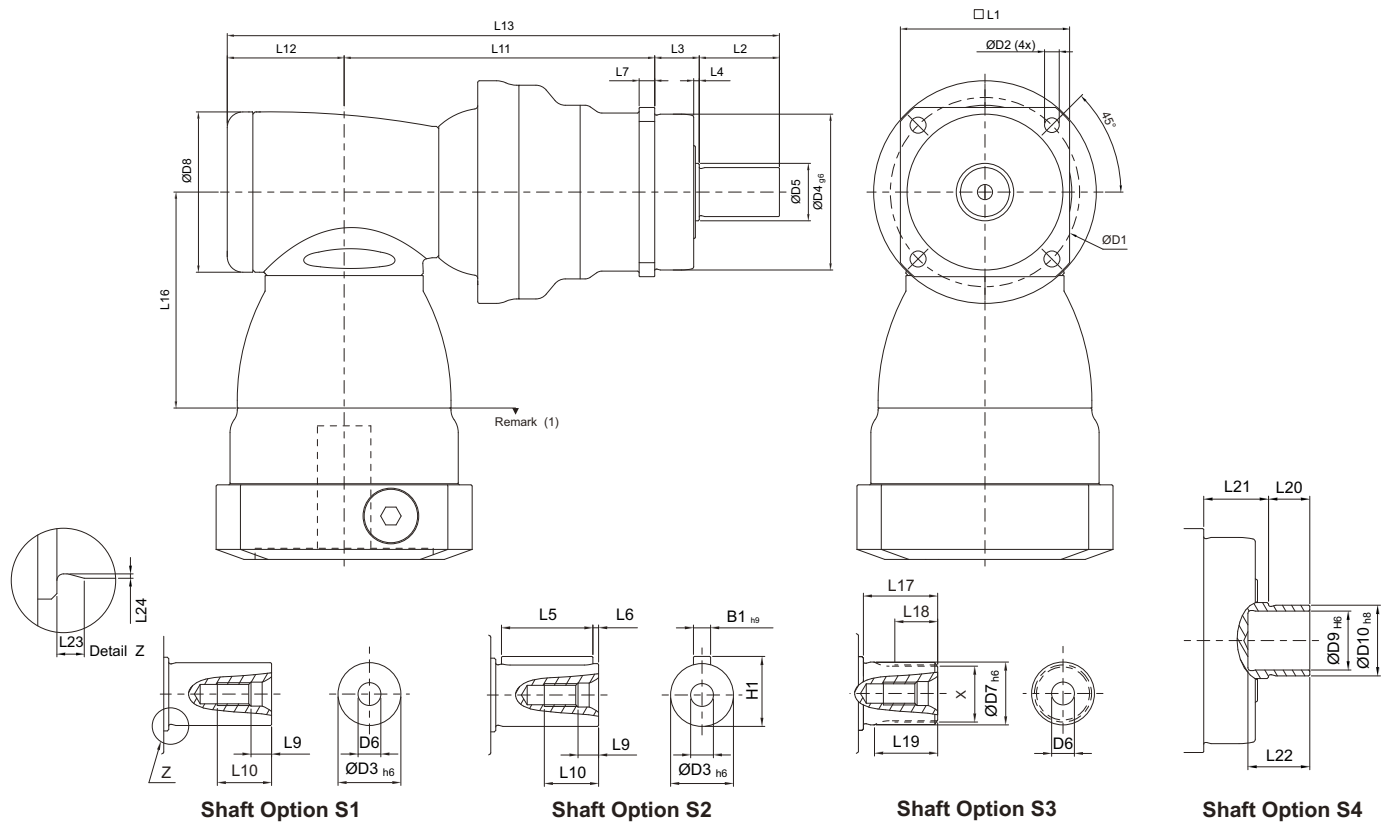

Shaft Option S1

Shaft Option S2

Shaft Option S3

Shaft Option S4

Dimension	AFHKC 060	AFHKC 075	AFHKC 100	AFHKC 140	AFHKC 180	AFHKC 210	AFHKC 240
D1	68	85	120	165	215	250	290
D2	5.5	7	9	11	13.5	17	17
D3 h6	16	22	32	40	55	75	85
D4 g6	60	70	90	130	160	180	200
D5	18.5	25.8	36.8	55.2	69.2	82.2	92.2
D6	M5 x 0.8P	M8 x 1.25P	M12 x 1.75P	M16 x 2P	M20 x 2.5P	M20 x 2.5P	M20 x 2.5P
D7 h6	16	22	32	40	55	75	85
D8	64	92	116	156	156	195	240
D9 H6	15	20	30	40	55	-	-
D10 h8	18	24	36	50	68	-	-
L1	62	76	101	141	182	215	245
L2	28	36	58	82	82	105	130
L3	20	20	30	30	30	38	40
L4	2	2.5	3	3	3	3	3
L5	25	32	50	63	70	90	125
L6	2	2	4	5	6	7	3
L7	6	7	10	12	15	17	22
L9	4.8	7.2	10	12	15	15	15
L10	12.5	19	28	36	42	42	42
L11	121.5	145.5	163	219	258	277.5	352
L12	46.5	61.5	76	97.5	97.5	105.5	141
L13	216	263	327	428.5	467.5	526	663
L16	81.5	113.5	147.5	196.5	196.5	229	260
L17	26	26	26	40	41.5	52	60
L18	15	15	15	20	21.5	28	36
L19	21	22.5	23	33.5	33.5	45	53
L20	12	14	18	22	23	-	-
L21	22	22	32	33	32	-	-
L22	19	21	25	30	30	-	-
L23	2	2.5	2.5	2.5	2.5	2.5	4
L24	0.3	0.4	0.4	0.4	0.4	0.4	0.5
B1 h9	5	6	10	12	16	20	22
H1	18	24.5	35	43	59	79.5	90
X DIN5480	W16 x 0.8 x 30 x 18 x 6m	W22 x 1.25 x 30 x 16 x 6m	W32 x 1.25 x 30 x 24 x 6m	W40 x 2 x 30 x 18 x 6m	W55 x 2 x 30 x 26 x 6m	W70 x 2 x 30 x 34 x 6m	W80 x 2 x 30 x 38 x 6m

(I) Dimensions are related to motor interface. Please contact APEX for details.

Selection of the optimum gearbox

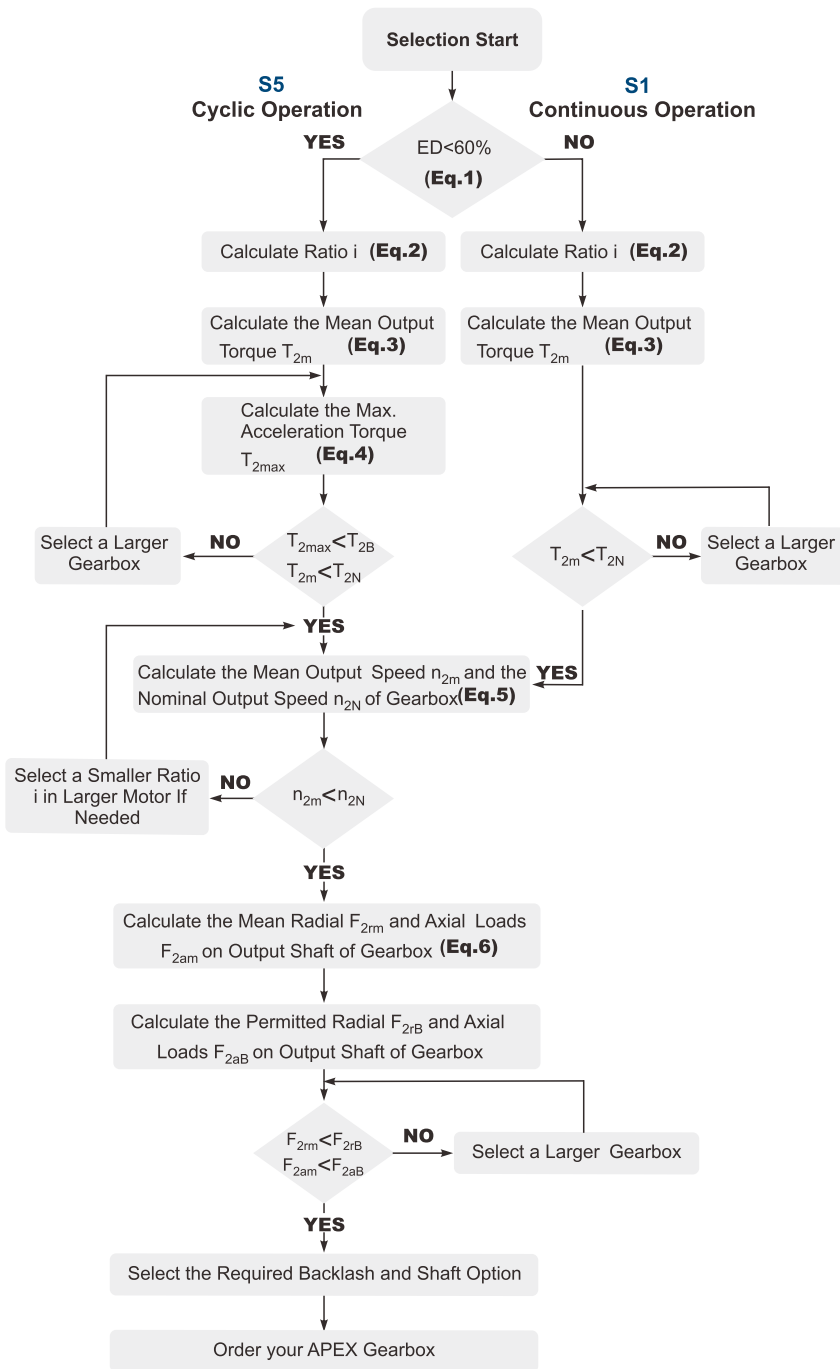

Recommended (for S5 Cycle Operation)

The general design is given for

$$\frac{J_L}{j^2} \leq 4 \times J_m$$

The optimal design is given for

$$\frac{J_L}{j^2} \cong J_m$$

J_L Load Inertia

J_m Motor Inertia

Liability Disclaimer:

APEX DYNAMICS, INC. endeavors to ensure the accuracy and reliability of the data in catalog.

APEX accepts no liability, whether in any form, for any loss or damage arising from any inaccuracy or omissions of this catalog.

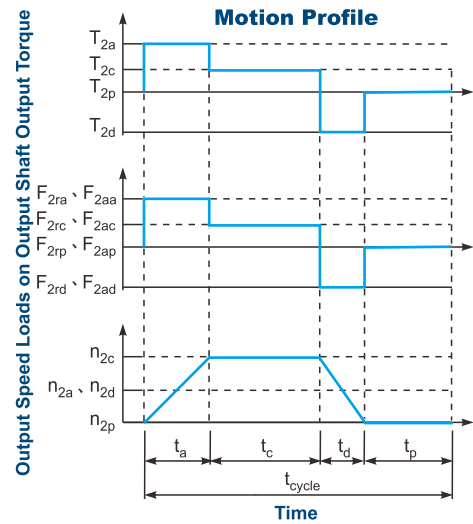

$$1. ED = \frac{t_a + t_c + t_d}{t_{cycle}} \times 100\%$$

Index : a. Acceleration, c. Constant, d. Deceleration, p. Pause (Eq. 1)

$$2. i \cong \frac{n_m}{n_{work}}$$

n_m Output Speed of the Motor

n_{work} Working Speed (Eq. 2)

$$3. T_{2m} = 3 \sqrt{\frac{n_{2a} \times t_a \times T_{2a}^3 + n_{2c} \times t_c \times T_{2c}^3 + n_{2d} \times t_d \times T_{2d}^3}{n_{2a} \times t_a + n_{2c} \times t_c + n_{2d} \times t_d}}$$

$$4. T_{2max} = T_{mB} \times i \times K_s \times \eta$$

where K_s is

K_s	No. of Cycles / hr
1.0	0 ~ 1,000
1.1	1,000 ~ 1,500
1.3	1,500 ~ 2,000
1.6	2,000 ~ 3,000
1.8	3,000 ~ 5,000

T_{mB} Max. Output Torque of the Motor

η Efficiency of the Gearbox (Eq. 4)

$$5. n_{2a} = n_{2d} = \frac{1}{2} \times n_{2c}$$

$$n_{2m} = \frac{n_{2a} \times t_a + n_{2c} \times t_c + n_{2d} \times t_d}{t_a + t_c + t_d}$$

$$n_{2N} = \frac{n_{1N}}{i} \quad (Eq. 5)$$

$$6. F_{2rm} = 3 \sqrt{\frac{n_{2a} \times t_a \times F_{2ra}^3 + n_{2c} \times t_c \times F_{2rc}^3 + n_{2d} \times t_d \times F_{2rd}^3}{n_{2a} \times t_a + n_{2c} \times t_c + n_{2d} \times t_d}}$$

$$F_{2am} = 3 \sqrt{\frac{n_{2a} \times t_a \times F_{2aa}^3 + n_{2c} \times t_c \times F_{2ac}^3 + n_{2d} \times t_d \times F_{2ad}^3}{n_{2a} \times t_a + n_{2c} \times t_c + n_{2d} \times t_d}} \quad (Eq. 6)$$