

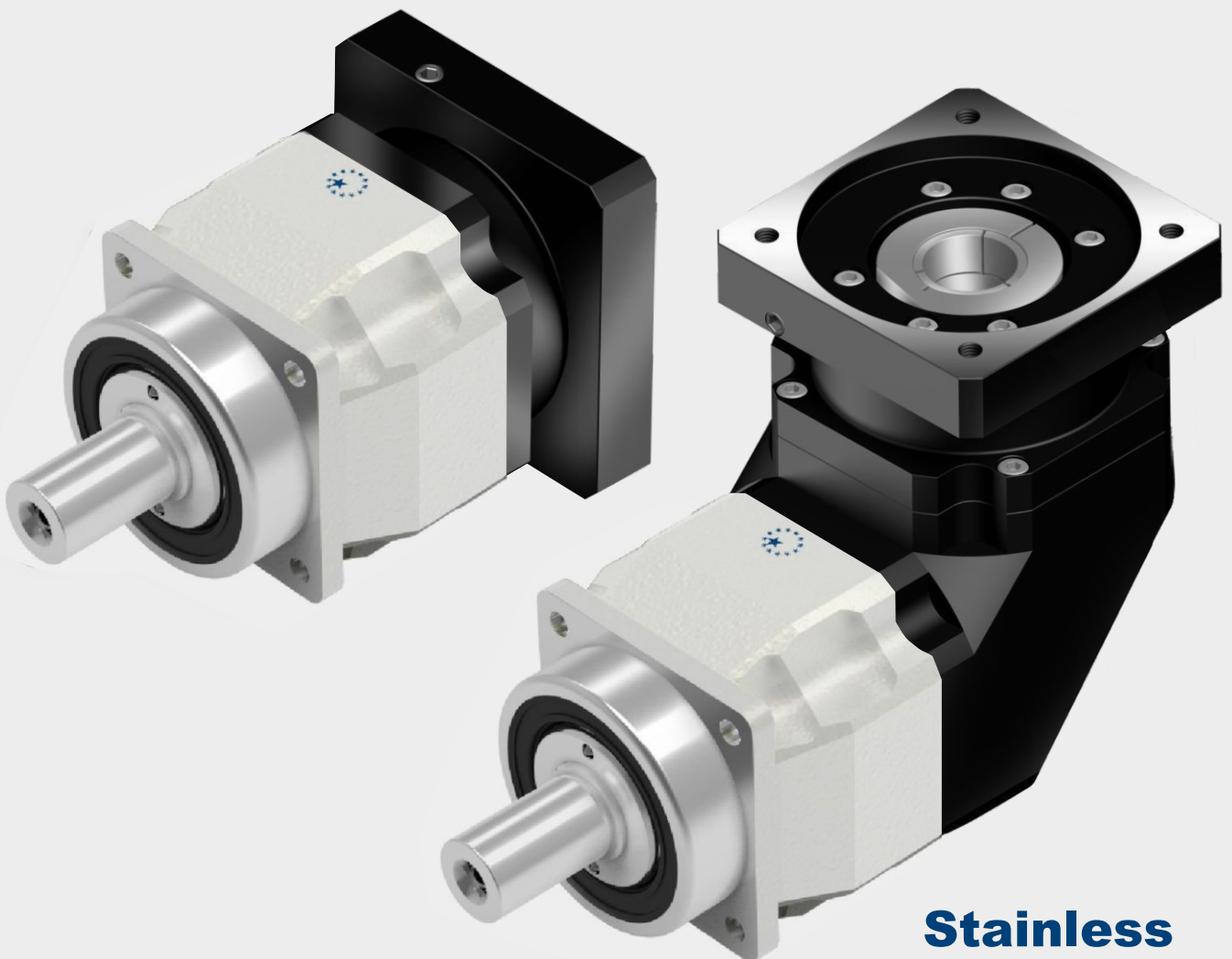

APEX DYNAMICS, INC.

**HIGH PRECISION
HIGH SPEED
PLANETARY GEARBOX**

AF / AFR Series



Stainless



Apex Dynamics, Inc. is the world's most productive manufacturer of servomotor drive planetary gearboxes for precision automation machinery. From our 800,000+ square foot ISO 9001:2008 manufacturing facility, based in Taichung, Taiwan, we manufacture to stock using the newest precision machine tools and quality test and inspection equipment. Complete focus on quality and precision allows us to produce our high quality gearheads at precision levels down to less than 1 arc minute (1/60 th of a degree), with consistency and high reliability.

Based on more than twenty years of accumulated manufacturing and marketing experience, plus the highest level of technical production capabilities, Apex Dynamics, Inc. designs and builds technically advanced, high speed, low backlash servo application planetary gearboxes. Our Break through patented technology (over 6 patents), provides the customer with the optimum high precision helical reducer at a reasonable price. We are continuously improving processes, finding proper and effective methods to provide customers new solutions for difficult applications, and developing new products.

The primary focus in daily operation is quality. We pride ourselves on our dedication to quality; our duty - is customer satisfaction.

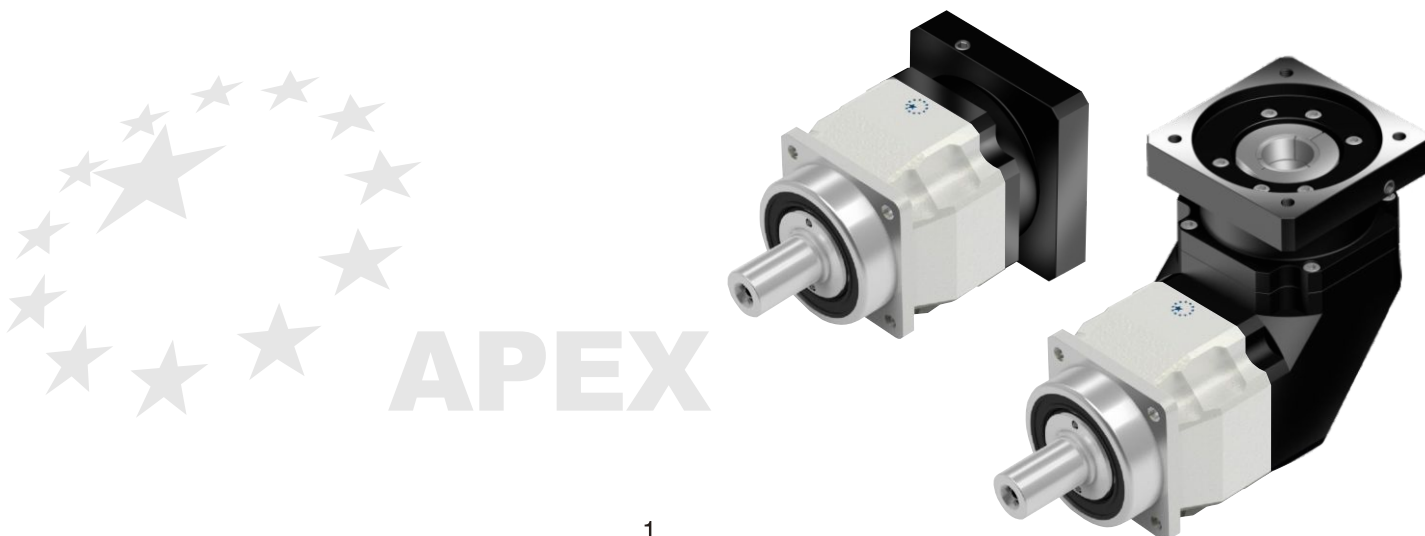

AF Series

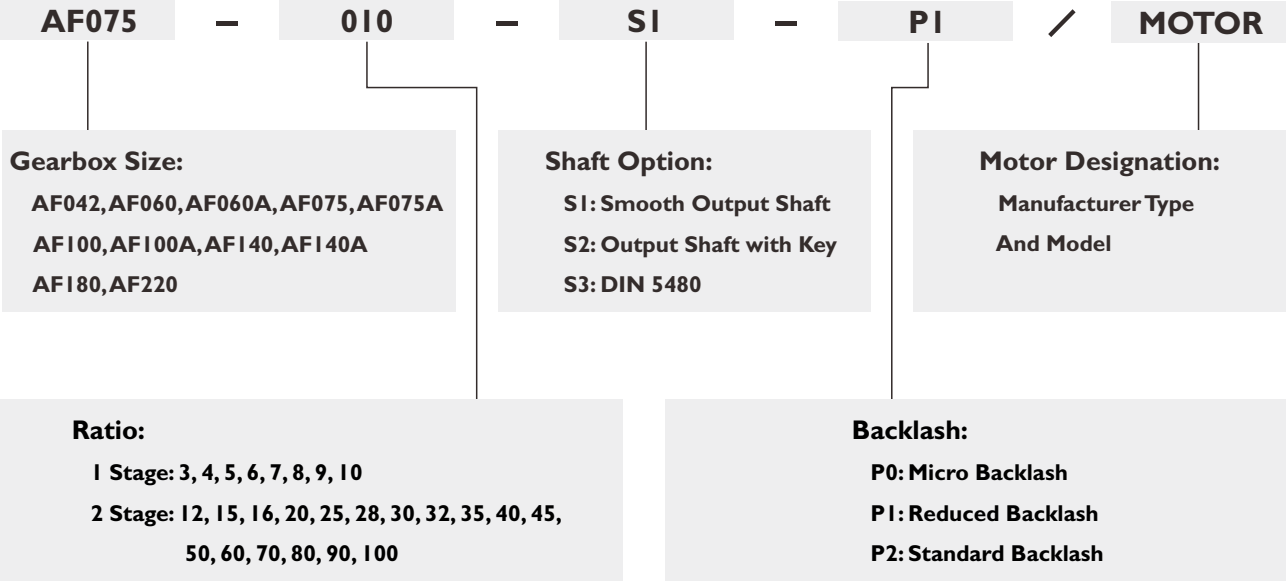

Ordering Example: **AF075-010-SI-PI / SIEMENS IFT6 04I-4AF7I**

AFR Series

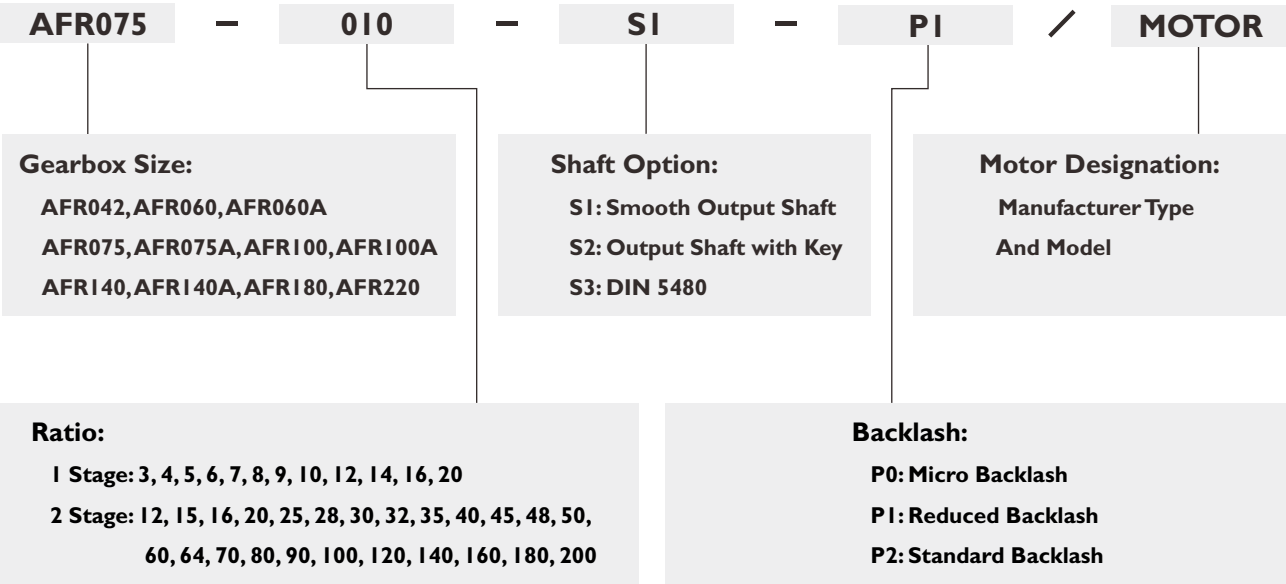

Ordering Example: **AFR075-010-SI-PI / SIEMENS IFT6 04I-4AF7I**



©2019 by APEX DYNAMICS, INC.
 APEX DYNAMICS, INC. reserves modification and copyrights of all technical specifications, illustrations and drawings in this catalog in allowance for continuous products development and advancement.
 For the newest data and information, please visit <http://www.apexdyna.com/>

Specifications / AF Series

Gearbox Performance

Model No.	Stage	Ratio ⁽¹⁾	AF042	AF060	AF060 A	AF075	AF075A	AF100	AF100A	AF140	AF140A	AF180	AF220	
Nominal Output Torque T_{2N}	1	3	20	55	-	130	-	208	-	342	-	588	1,140	
		4	19	50	-	140	-	290	-	542	-	1,050	1,700	
		5	22	60	-	160	-	330	-	650	-	1,200	2,000	
		6	20	55	-	150	-	310	-	600	-	1,100	1,900	
		7	19	50	-	140	-	300	-	550	-	1,100	1,800	
		8	17	45	-	120	-	260	-	500	-	1,000	1,600	
		9	14	40	-	100	-	230	-	450	-	900	1,500	
		10	14	40	-	100	-	230	-	450	-	900	1,500	
		2	12	19	50	50	140	140	290	290	542	542	1,050	1,700
			15	20	55	55	130	130	208	208	342	342	588	1,140
	16		19	50	50	140	140	290	290	542	542	1,050	1,700	
	20		19	50	50	140	140	290	290	542	542	1,050	1,700	
	25		22	60	60	160	160	330	330	650	650	1,200	2,000	
	28		19	50	50	140	140	300	300	550	550	1,100	1,800	
	30		20	55	55	150	150	310	310	600	600	1,100	1,900	
	32		17	45	45	120	120	260	260	500	500	1,000	1,600	
	35		19	50	50	140	140	300	300	550	550	1,100	1,800	
	40		17	45	45	120	120	260	260	500	500	1,000	1,600	
	45	14	40	40	100	100	230	230	450	450	900	1,500		
	50	22	60	60	160	160	330	330	650	650	1,200	2,000		
60	20	55	55	150	150	310	310	600	600	1,100	1,900			
70	19	50	50	140	140	300	300	550	550	1,100	1,800			
80	17	45	45	120	120	260	260	500	500	1,000	1,600			
90	14	40	40	100	100	230	230	450	450	900	1,500			
100	14	40	40	100	100	230	230	450	450	900	1,500			
Emergency Stop Torque $T_{2NOT}^{(2)}$	Nm	1,2	3 times of Nominal Output Torque											
Nominal Input Speed n_{IN}	rpm	1,2	3~100											
Max. Input Speed n_{IB}	rpm	1,2	3~100	10,000	10,000	10,000	8,000	8,000	8,000	8,000	6,000	6,000	6,000	4,000
Micro Backlash P0	arcmin	1	3~10											
		2	12~100											
Reduced Backlash P1	arcmin	1	≤3											
		2	12~100											
Standard Backlash P2	arcmin	1	≤5											
		2	12~100											
Torsional Rigidity	Nm/arcmin	1,2	3~100	3	7	7	14	14	25	25	50	50	145	225
Max. Radial Load $F_{2R}^{(3)}$	N	1,2	3~100	610	1,400	1,400	4,100	4,100	9,200	9,200	14,000	14,000	18,000	33,000
Max. Axial Load $F_{2AB}^{(3)}$	N	1,2	3~100	320	1,100	1,100	3,700	3,700	5,820	5,820	11,400	11,400	19,500	25,000
Max. Tilting Moment M_{2K}	N m	1,2	3~100	20	85	85	380	380	970	970	1,840	1,840	2,740	5,030
Efficiency η	%	1	3~10											
		2	12~100											
Weight	kg	1	3~10											
		2	12~100											
Operating Temp	°C	1,2	3~100											
Lubrication		1,2	3~100											
Degree of Gearbox Protection		1,2	3~100											
Mounting Position		1,2	3~100											
Noise ⁽⁴⁾	dB(A)	1,2	3~100	≤56	≤58	≤60	≤60	≤63	≤63	≤65	≤65	≤67	≤67	≤70

(1) Ratio ($i=N_{in}/N_{out}$)

(2) Max. acceleration torque $T_{2B} = 60\%$ of T_{2NOT}

(3) Applied to the output shaft center at 100 rpm

(4) The values are measured by gearbox with ratio 10 (1-stage) or ratio 100 (2-stage), no loading at 3,000 RPM or at the respective Nominal Input Speed by bigger model size. By lower ratio and/or higher RPM, the values could be higher.

Max. Tilting Moment M_{2K}

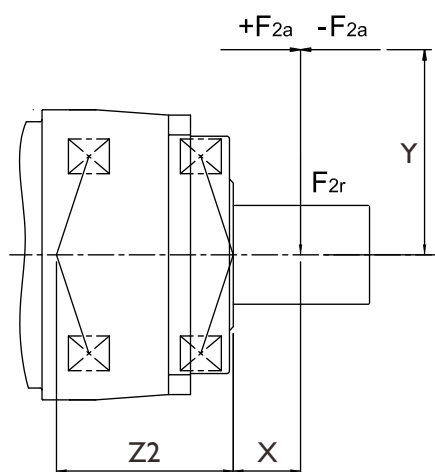

$$M_{2K} = \frac{F_{2a} * Y + F_{2r} * (X+Z2)}{1000}$$

M_{2K} : [Nm]

F_{2a}, F_{2r} : [N]

$X, Y, Z2$: [mm]

AF / AFR	042	060	075	100	140	180	220
Z2 [mm]	31	66.5	88.7	96	114.2	138.7	127.1

Note :Applied to the output shaft center at 100 rpm.

Gearbox Inertia

Model No.	Stage	Ratio	AF042	AF060	AF060A	AF075	AF075A	AF100	AF100A	AF140	AF140A	AF180	AF220	
Mass Moments of Inertia J_i	1	3	0.03	0.16	-	0.61	-	3.25	-	9.21	-	28.98	69.61	
		4	0.03	0.14	-	0.48	-	2.74	-	7.54	-	23.67	54.37	
		5	0.03	0.13	-	0.47	-	2.71	-	7.42	-	23.29	53.27	
		6	0.03	0.13	-	0.45	-	2.65	-	7.25	-	22.75	51.72	
		7	0.03	0.13	-	0.45	-	2.62	-	7.14	-	22.48	50.97	
		8	0.03	0.13	-	0.44	-	2.58	-	7.07	-	22.59	50.84	
		9	0.03	0.13	-	0.44	-	2.57	-	7.04	-	22.53	50.63	
		10	0.03	0.13	-	0.44	-	2.57	-	7.03	-	22.51	50.56	
		12	0.03	0.03	0.16	0.16	0.61	0.61	3.25	3.25	9.21	9.21	28.98	28.98
		15	0.03	0.03	0.13	0.13	0.47	0.47	2.71	2.71	7.42	7.42	23.29	23.29
	16	0.03	0.03	0.14	0.14	0.48	0.48	2.74	2.74	7.54	7.54	23.67	23.67	
	20	0.03	0.03	0.13	0.13	0.47	0.47	2.71	2.71	7.42	7.42	23.29	23.29	
	25	0.03	0.03	0.13	0.13	0.47	0.47	2.71	2.71	7.42	7.42	23.29	23.29	
	28	0.03	0.03	0.14	0.14	0.48	0.48	2.74	2.74	7.54	7.54	23.67	23.67	
	30	0.03	0.03	0.13	0.13	0.47	0.47	2.71	2.71	7.42	7.42	23.29	23.29	
	32	0.03	0.03	0.14	0.14	0.48	0.48	2.74	2.74	7.54	7.54	23.67	23.67	
	35	0.03	0.03	0.13	0.13	0.47	0.47	2.71	2.71	7.42	7.42	23.29	23.29	
	40	0.03	0.03	0.13	0.13	0.47	0.47	2.71	2.71	7.42	7.42	23.29	23.29	
	45	0.03	0.03	0.13	0.13	0.47	0.47	2.71	2.71	7.42	7.42	23.29	23.29	
	50	0.03	0.03	0.13	0.13	0.44	0.44	2.57	2.57	7.03	7.03	22.51	22.51	
60	0.03	0.03	0.13	0.13	0.44	0.44	2.57	2.57	7.03	7.03	22.51	22.51		
70	0.03	0.03	0.13	0.13	0.44	0.44	2.57	2.57	7.03	7.03	22.51	22.51		
80	0.03	0.03	0.13	0.13	0.44	0.44	2.57	2.57	7.03	7.03	22.51	22.51		
90	0.03	0.03	0.13	0.13	0.44	0.44	2.57	2.57	7.03	7.03	22.51	22.51		
100	0.03	0.03	0.13	0.13	0.44	0.44	2.57	2.57	7.03	7.03	22.51	22.51		

Dimensions (1-stage, Ratio $i=3\sim 10$) / AF Series

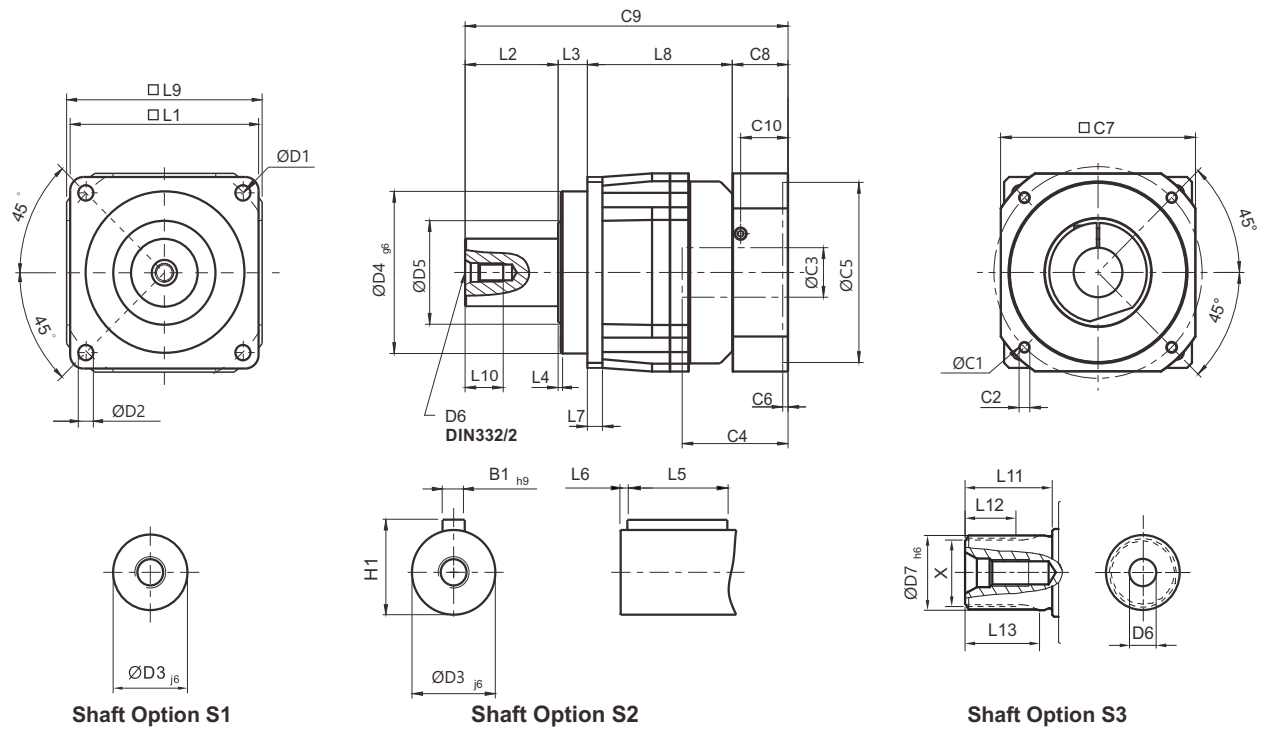

[unit: mm]

Dimension	AF042	AF060	AF075	AF100	AF140	AF180	AF220
D1	50	68	85	120	165	215	250
D2	3.4	5.5	6.8	9	11	13	17
D3 j6	13	16	22	32	40	55	75
D4 g6	35	60	70	90	130	160	180
D5	22	45	60	80	75	95	115
D6	M4 x 0.7P	M5 x 0.8P	M8 x 1.25P	M12 x 1.75P	M16 x 2P	M20 x 2.5P	M20 x 2.5P
D7 h6	-	16	22	32	40	55	75
L1	42	62	76	105	142	180	220
L2	19.5	28.5	36	58	82	82	105
L3	6.5	20	20	30	30	30	33
L4	1	1.5	2	2	3	3	3
L5	16	25	32	40	63	70	90
L6	2	2	3	5	5	6	7
L7	4	6	7	10	12	15	20
L8	31	54.5	86.5	89.5	110	150	163.5
L9	42	60	90	115	142	180	220
L10	10	12.5	19	28	36	42	42
L11	-	26	26	26	40	41.5	52
L12	-	15	15	15	20	21.5	28
L13	-	21	22.5	23	33.5	33.5	45
C1 ¹	46	70	100	130	165	215	235
C2 ¹	M4 x 0.7P	M5 x 0.8P	M6 x 1P	M8 x 1.25P	M10 x 1.5P	M12 x 1.75P	M12 x 1.75P
C3 ¹	≤11 / ≤12 ²	≤14 / ≤16 ²	≤19 / ≤24 ²	≤32	≤38	≤48	≤55
C4 ¹	25	34	40	50	60	85	116
C5 ¹	30	50	80	110	130	180	200
C6 ¹	3.5	8	4	5	6	6	6
C7 ¹	42	60	90	115	142	190	220
C8 ¹	29.5	19	17	19.5	22.5	29	63
C9 ¹	86.5	122	159.5	197	244.5	291	364.5
C10 ¹	8.75	13.5	10.75	13	15	20.75	53
B1 h9	5	5	6	10	12	16	20
H1	15	18	24.5	35	43	59	79.5
X DIN5480	-	W16 x 0.8 x 30 x 18 x 6m	W22 x 1.25 x 30 x 16 x 6m	W32 x 1.25 x 30 x 24 x 6m	W40 x 2 x 30 x 18 x 6m	W55 x 2 x 30 x 26 x 6m	W70 x 2 x 30 x 34 x 6m

1. C1~C10 are motor specific dimensions (metric std shown). Refer to www.apexdyna.com and Design Tool to view your specific motor mounting system.

2. AF042M1 ratio 5, 10 offers C3 ≤ 12 option; AF060M1 ratio 5, 10 offers C3 ≤ 16 option; AF075M1 offers C3 ≤ 24 option.

Dimensions (2-stage, Ratio i=12~100) / AF Series

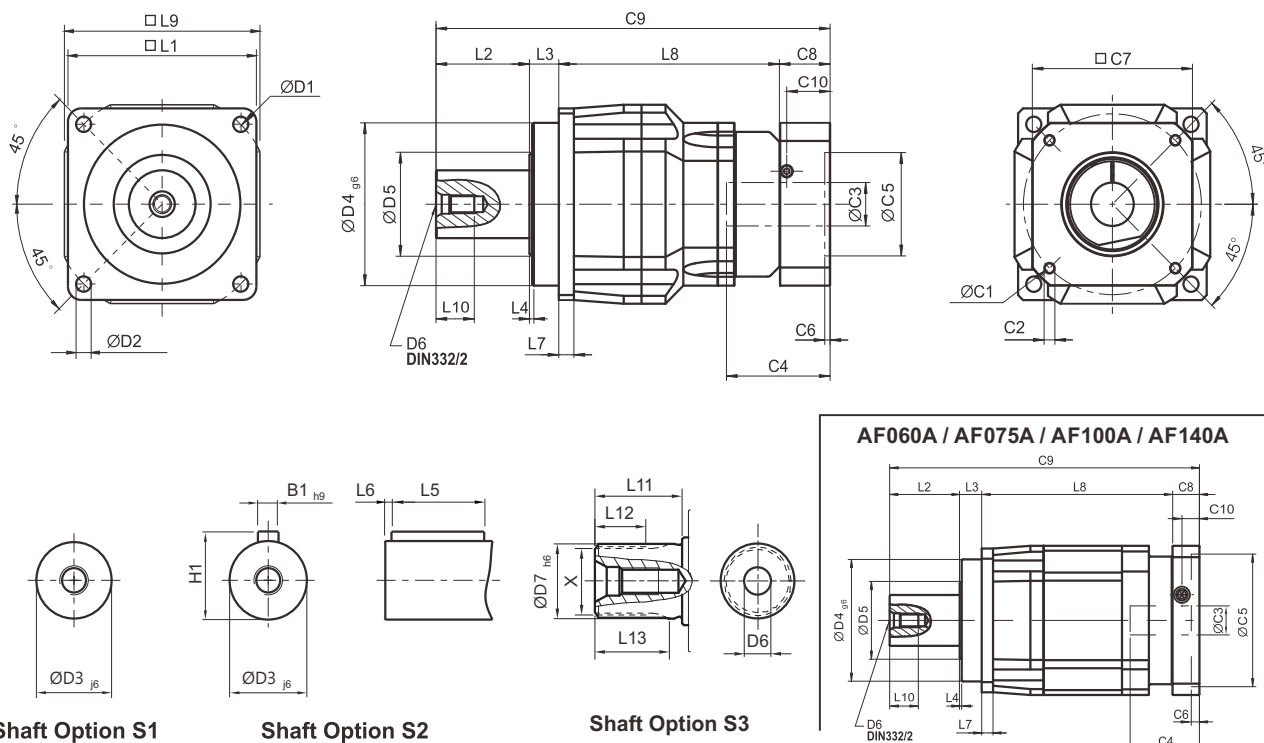

[unit: mm]

Dimension	AF042	AF060	AF060 A	AF075	AF075A	AF100	AF100A	AF140	AF140A	AF180	AF220
D1	50	68		85		120		165		215	250
D2	3.4	5.5		6.8		9		11		13	17
D3 j6	13	16		22		32		40		55	75
D4 g6	35	60		70		90		130		160	180
D5	22	45		60		80		75		95	115
D6	M4 x 0.7P	M5 x 0.8P		M8 x 1.25P		M12 x 1.75P		M16 x 2P		M20 x 2.5P	M20 x 2.5P
D7	56	16		22		32		40		55	75
L1	42	62		76		105		142		180	220
L2	19.5	28.5		36		58		82		82	105
L3	6.5	20		20		30		30		30	33
L4	1	1.5		2		2		3		3	3
L5	16	25		32		40		63		70	90
L6	2	2		3		5		5		6	7
L7	4	6		7		10		12		15	20
L8	58.5	65.5	91.5	119.5	134.5	131	150.5	166.5	181.5	205.5	248
L9	42	60		90		115		142		180	220
L10	10	12.5		19		28		36		42	42
L11	-	26		26		26		40		41.5	52
L12	-	15		15		15		20		21.5	28
L13	-	21		22.5		23		33.5		33.5	45
C1 ³	46	46	70	70	100	100	130	130	165	165	215
C2 ³	M4 x 0.7P	M4 x 0.7P	M5 x 0.8P	M5 x 0.8P	M6 x 1P	M6 x 1P	M8 x 1.25P	M8 x 1.25P	M10 x 1.5P	M10 x 1.5P	M12 x 1.75P
C3 ³	≤11 / ≤12 ⁴	≤11 / ≤12 ⁴	≤14 / ≤16 ⁴	≤14 / ≤15.875 / ≤16 ⁴	≤19 / ≤24 ⁴	≤19 / ≤24 ⁴	≤32	≤32	≤38	≤38	≤48
C4 ³	25	25	34	34	40	40	50	50	60	60	85
C5 ³	30	30	50	50	80	80	110	110	130	130	180
C6 ³	3.5	3.5	8	8	4	4	5	5	6	6	6
C7 ³	42	42	60	60	90	90	115	115	142	142	190
C8 ³	29.5	29.5	19	19	17	17	19.5	19.5	22.5	22.5	29
C9 ³	114	143.5	159	194.5	207.5	207.5	258	298	316	340	415
C10 ³	8.75	8.75	13.5	13.5	10.75	10.75	13	13	15	15	20.75
B1 h9	5	5		6		10		12		16	20
H1	15	18		24.5		35		43		59	79.5
X DIN5480	-	W16 x 0.8 x 30 x 18 x 6m		W22 x 1.25 x 30 x 16 x 6m		W32 x 1.25 x 30 x 24 x 6m		W40 x 2 x 30 x 18 x 6m		W55 x 2 x 30 x 26 x 6m	W70 x 2 x 30 x 34 x 6m

3. C1~C10 are motor specific dimensions (metric std shown). Refer to www.apexdyna.com and Design Tool to view your specific motor mounting system.

4. AF042M1 offers C3 ≤ 12 option; AF060/A M1 offers C3 ≤ 12/16 option; AF075/A M1 offers C3 ≤ 16/24 option; AF075 M2 offers C3 ≤ 15.875 option. AF100M1 offers C3 ≤ 24 option.

Specifications / AFR Series

Gearbox Performance

Model No.	Stage	Ratio ⁽¹⁾	AFR042	AFR060	AFR060 A	AFR075	AFR075A	AFR100	AFR100A	AFR140	AFR140A	AFR180	AFR220	
Nominal Output Torque T_{2N}	1	3	9	36	-	90	-	195	-	342	-	588	1,140	
		4	12	48	-	120	-	260	-	520	-	1,040	1,680	
		5	15	60	-	150	-	325	-	650	-	1,200	2,000	
		6	18	55	-	150	-	310	-	600	-	1,100	1,900	
		7	19	50	-	140	-	300	-	550	-	1,100	1,800	
		8	17	45	-	120	-	260	-	500	-	1,000	1,600	
		9	14	40	-	100	-	230	-	450	-	900	1,500	
		10	14	60	-	150	-	325	-	650	-	1,200	2,000	
		12	-	55	-	150	-	310	-	600	-	1,100	1,900	
		14	-	42	-	140	-	300	-	550	-	1,100	1,800	
		16	-	45	-	120	-	260	-	500	-	1,000	1,600	
	20	-	40	-	100	-	230	-	450	-	900	1,500		
	2	12	12	-	-	-	-	-	-	-	-	-	-	-
		15	14	-	-	-	-	-	-	-	-	-	-	-
		16	15	-	-	-	-	-	-	-	-	-	-	-
		20	14	-	-	-	-	-	-	-	-	-	-	-
		25	15	60	60	150	150	325	325	650	650	1,200	2,000	
		28	19	50	50	140	140	300	300	550	550	1,100	1,800	
		30	20	55	55	150	150	310	310	600	600	1,100	1,900	
		32	17	45	45	120	120	260	260	500	500	1,000	1,600	
		35	19	50	50	140	140	300	300	550	550	1,100	1,800	
		40	17	45	45	120	120	260	260	500	500	1,000	1,600	
		45	14	40	40	100	100	230	230	450	450	900	1,500	
		48	-	-	55	150	150	310	310	600	600	1,100	1,900	
		50	14	60	60	150	150	325	325	650	650	1,200	2,000	
		60	20	55	55	150	150	310	310	600	600	1,100	1,900	
		64	-	-	45	120	120	260	260	500	500	1,000	1,600	
		70	19	50	50	140	140	300	300	550	550	1,100	1,800	
		80	17	45	45	120	120	260	260	500	500	1,000	1,600	
		90	14	40	40	100	100	230	230	450	450	900	1,500	
		100	14	40	60	150	150	325	325	650	650	1,200	2,000	
	120	-	-	55	150	150	310	310	600	600	1,100	1,900		
140	-	-	50	140	140	300	300	550	550	1,100	1,800			
160	-	-	45	120	120	260	260	500	500	1,000	1,600			
180	-	-	40	100	100	230	230	450	450	900	1,500			
200	-	-	40	100	100	230	230	450	450	900	1,500			
Emergency Stop Torque $T_{2NOT}^{(2)}$	Nm	1,2	3~200	3 times of Nominal Output Torque										
Nominal Input Speed n_{1N}	rpm	1,2	3~200	5,000	5,000	5,000	4,000	4,000	4,000	4,000	3,000	3,000	3,000	2,000
Max. Input Speed n_{1B}	rpm	1,2	3~200	10,000	10,000	10,000	8,000	8,000	8,000	8,000	6,000	6,000	6,000	4,000
Micro Backlash P0	arcmin	1	3~20	-	-	-	≤2	-	≤2	-	≤2	-	≤2	≤2
		2	12~200	-	-	-	≤4	≤4	≤4	≤4	≤4	≤4	≤4	≤4
Reduced Backlash P1	arcmin	1	3~20	≤4	≤4	-	≤4	-	≤4	-	≤4	-	≤4	≤4
		2	12~200	≤7	≤7	≤7	≤7	≤7	≤7	≤7	≤7	≤7	≤7	≤7
Standard Backlash P2	arcmin	1	3~20	≤6	≤6	-	≤6	-	≤6	-	≤6	-	≤6	≤6
		2	12~200	≤9	≤9	≤9	≤9	≤9	≤9	≤9	≤9	≤9	≤9	≤9
Torsional Rigidity	Nm/arcmin	1,2	3~200	3	7	7	14	14	25	25	50	50	145	225
Max. Radial Load $F_{2RB}^{(3)}$	N	1,2	3~200	610	1,400	1,400	4,100	4,100	9,200	9,200	14,000	14,000	18,000	33,000
Max. Axial Load $F_{2AB}^{(3)}$	N	1,2	3~200	320	1,100	1,100	3,700	3,700	5,800	5,800	11,400	11,400	19,500	16,300
Max. Tilting Moment M_{2K}	N m		3~200	20	85	85	380	380	970	970	1,840	1,840	2,740	5,030
Efficiency η	%	1	3~20	≥95%										
		2	12~200	≥92%										
Weight	kg	1	3~20	0.9	2.1	-	6.4	-	11.3	-	22.5	-	44	77
		2	12~200	1.2	1.9	2.8	4.8	8	10.6	15.1	21	29.2	41	75
Operating Temp	°C	1,2	3~200	-10°C~+90°C										
Lubrication		1,2	3~200	Lubricant										
Degree of Gearbox Protection		1,2	3~200	IP67										
Mounting Position		1,2	3~200	all directions										
Noise ⁽⁴⁾	dB(A)	1,2	3~200	≤61	≤63	≤65	≤65	≤68	≤68	≤70	≤70	≤72	≤72	≤74

(1) Ratio ($i=N_{in}/N_{out}$)

(2) Max. acceleration torque $T_{2B} = 60\%$ of T_{2NOT}

(3) Applied to the output shaft center at 100 rpm

(4) The values are measured by gearbox with ratio 10 (1-stage) or ratio 100 (2-stage), no loading at 3,000 RPM

or at the respective Nominal Input Speed by bigger model size.

By lower ratio and/or higher RPM, the values could be higher.

Gearbox Inertia

Model No.		Stage	Ratio	AFR042	AFR060	AFR060 A	AFR075	AFR075A	AFR100	AFR100A	AFR140	AFR140A	AFR180	AFR220	
Mass Moments of Inertia J_i	kg · cm ²	1	3~10	0.09	0.35	—	2.25	—	6.84	—	23.4	—	68.9	135.4	
			12~20	—	0.31	—	1.87	—	6.25	—	21.8	—	65.6	119.8	
		2	12~20	0.09	—	—	—	—	—	—	—	—	—	—	—
			25~90	0.09	0.09	0.35	0.35	2.25	2.25	6.84	6.84	23.4	23.4	68.9	
			48, 64	—	—	0.31	0.31	1.87	1.87	6.25	6.25	21.8	21.8	65.6	
			100~200	—	—	0.31	0.31	1.87	1.87	6.25	6.25	21.8	21.8	65.6	

Dimensions (1-stage, Ratio $i=3\sim 20$) / AFR Series

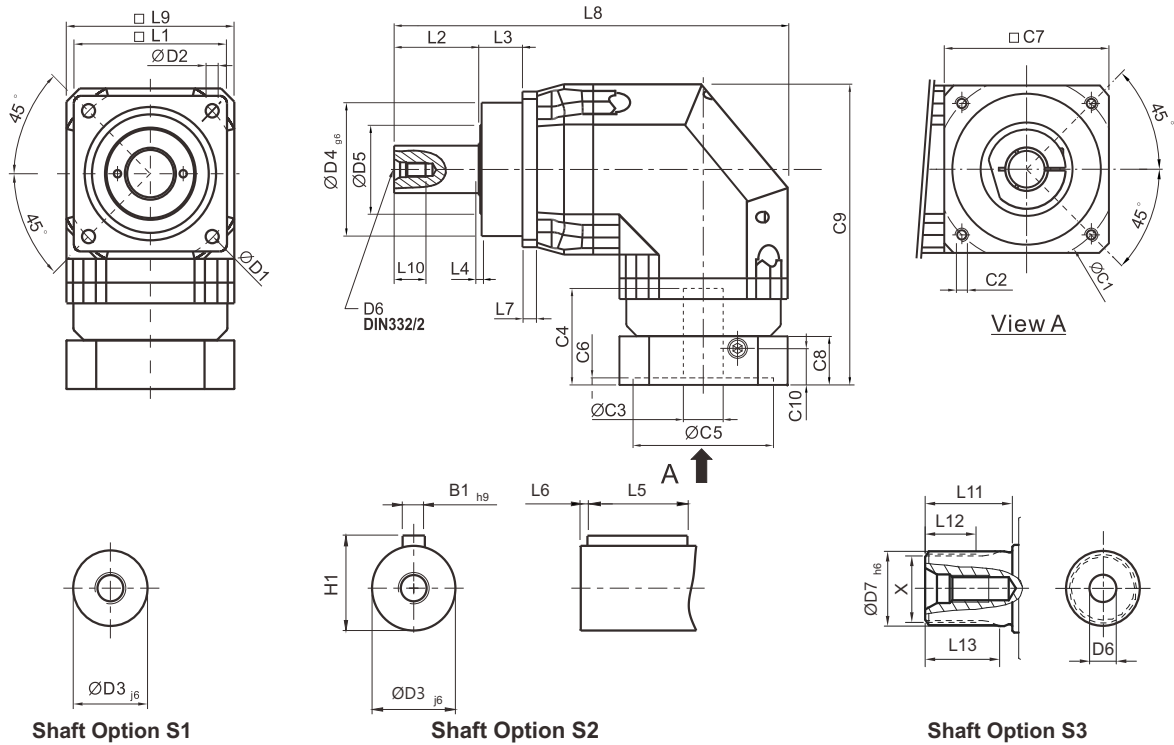

[unit: mm]

Dimension	AFR042	AFR060	AFR075	AFR100	AFR140	AFR180	AFR220
D1	50	68	85	120	165	215	250
D2	3.4	5.5	6.8	9	11	13	17
D3 j6	13	16	22	32	40	55	75
D4 g6	35	60	70	90	130	160	180
D5	22	45	60	80	75	95	115
D6	M4 x 0.7P	M5 x 0.8P	M8 x 1.25P	M12 x 1.75P	M16 x 2P	M20 x 2.5P	M20 x 2.5P
D7 h6	-	16	22	32	40	55	75
L1	42	62	76	105	142	180	220
L2	19.5	28.5	36	58	82	82	105
L3	6.5	20	20	30	30	30	33
L4	1	1.5	2	2	3	3	3
L5	16	25	32	40	63	70	90
L6	2	2	3	5	5	6	7
L7	4	6	7	10	12	15	20
L8	111.5	150	219	269.5	338.5	397	484
L9	42	60	90	115	142	180	220
L10	10	12.5	19	28	36	42	42
L11	-	26	26	26	40	41.5	52
L12	-	15	15	15	20	21.5	28
L13	-	21	22.5	23	33.5	33.5	45
C1 ¹	46	70	100	130	165	215	235
C2 ¹	M4 x 0.7P	M5 x 0.8P	M6 x 1P	M8 x 1.25P	M10 x 1.5P	M12 x 1.75P	M12 x 1.75P
C3 ¹	≤11 / ≤12 ²	≤14 / ≤16 ²	≤19 / ≤24 ²	≤32	≤38	≤48	≤55
C4 ¹	25	34	40	50	60	85	116
C5 ¹	30	50	80	110	130	180	200
C6 ¹	3.5	8	4	5	6	6	6
C7 ¹	42	60	90	115	142	190	220
C8 ¹	29.5	19	17	19.5	22.5	29	63
C9 ¹	90.5	111.5	152.5	191.5	235.5	303.5	378.5
C10 ¹	8.75	13.5	10.75	13	15	20.75	53
B1 h9	5	5	6	10	12	16	20
H1	15	18	24.5	35	43	59	79.5
X DIN5480	-	W16 x 0.8 x 30 x 18 x 6m	W22 x 1.25 x 30 x 16 x 6m	W32 x 1.25 x 30 x 24 x 6m	W40 x 2 x 30 x 18 x 6m	W55 x 2 x 30 x 26 x 6m	W70 x 2 x 30 x 34 x 6m

1. C1~C10 are motor specific dimensions (metric std shown). Refer to www.apexdyna.com and Design Tool to view your specific motor mounting system.
 2. AFR042M1 offers C3 ≤ 12 option; AFR060M1 offers C3 ≤ 16 option; AFR075M1 offers C3 ≤ 24 option.

Dimensions (2-stage, Ratio i=12~200) / AFR Series

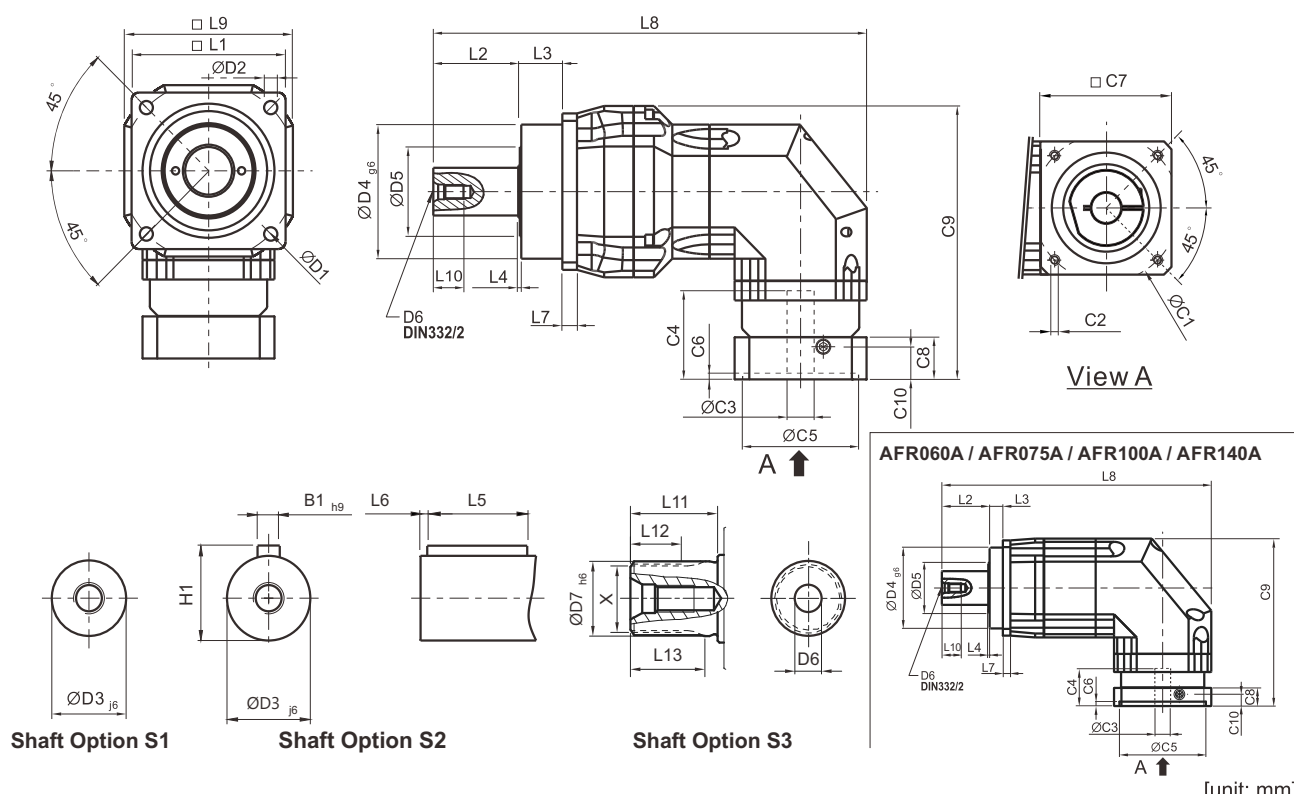

[unit: mm]

Dimension	AFR042	AFR060	AFR060 A	AFR075	AFR075A	AFR100	AFR100A	AFR140	AFR140A	AFR180	AFR220
D1	50	68		85		120		165		215	250
D2	3.4	5.5		6.8		9		11		13	17
D3 j6	13	16		22		32		40		55	75
D4 g6	35	60		70		90		130		160	180
D5	22	45		60		80		75		95	115
D6	M4 x 0.7P	M5 x 0.8P		M8 x 1.25P		M12 x 1.75P		M16 x 2P		M20 x 2.5P	M20 x 2.5P
D7	-	16		22		32		40		55	75
L1	42	62		76		105		142		180	220
L2	19.5	28.5		36		58		82		82	105
L3	6.5	20		20		30		30		30	33
L4	1	1.5		2		2		3		3	3
L5	16	25		32		40		63		70	90
L6	2	2		3		5		5		6	7
L7	4	6		7		10		12		15	20
L8	139	168.5	187	222.5	267	295.5	330.5	370.5	410	434	521
L9	42	60		90		115		142		180	220
L10	10	12.5		19		28		36		42	42
L11	-	26		26		26		40		41.5	52
L12	-	15		15		15		20		21.5	28
L13	-	21		22.5		23		33.5		33.5	45
C1 ³	46	46	70	70	100	100	130	130	165	165	215
C2 ³	M4 x 0.7P	M4 x 0.7P	M5 x 0.8P	M5 x 0.8P	M6 x 1P	M6 x 1P	M8 x 1.25P	M8 x 1.25P	M10 x 1.5P	M10 x 1.5P	M12 x 1.75P
C3 ³	≤11 / ≤12 ⁴	≤11 / ≤12 ⁴	≤14 / ≤16 ⁴	≤14 / ≤15.875 / ≤16 ⁴	≤19 / ≤24 ⁴	≤19 / ≤24 ⁴	≤32	≤32	≤38	≤38	≤48
C4 ³	25	25	34	34	40	40	50	50	60	60	85
C5 ³	30	30	50	50	80	80	110	110	130	130	180
C6 ³	3.5	3.5	8	8	4	4	5	5	6	6	6
C7 ³	42	42	60	60	90	90	115	115	142	142	190
C8 ³	29.5	29.5	19	19	17	17	19.5	19.5	22.5	22.5	29
C9 ³	90.5	99.5	111.5	126.5	152.5	165	191.5	205	235.5	254.5	323.5
C10 ³	8.75	8.75	13.5	13.5	10.75	10.75	13	13	15	15	20.75
B1 h9	5	5		6		10		12		16	20
H1	15	18		24.5		35		43		59	79.5
X DIN5480	-	W16 x 0.8 x 30 x 18 x 6m		W22 x 1.25 x 30 x 16 x 6m		W32 x 1.25 x 30 x 24 x 6m		W40 x 2 x 30 x 18 x 6m		W55 x 2 x 30 x 26 x 6m	W70 x 2 x 30 x 34 x 6m

3. C1-C10 are motor specific dimensions (metric std shown). Refer to www.apexdyna.com and Design Tool to view your specific motor mounting system.

4. AFR042MI offers C3 ≤ 12 option; AFR060/A M1 offers C3 ≤ 12/16 option; AFR075/A M1 offers C3 ≤ 16/24 option; AFR075 M2 offers C3 ≤ 15.875. AFR100MI offers C3 ≤ 24 option.

Selection of the Optimum Gearbox

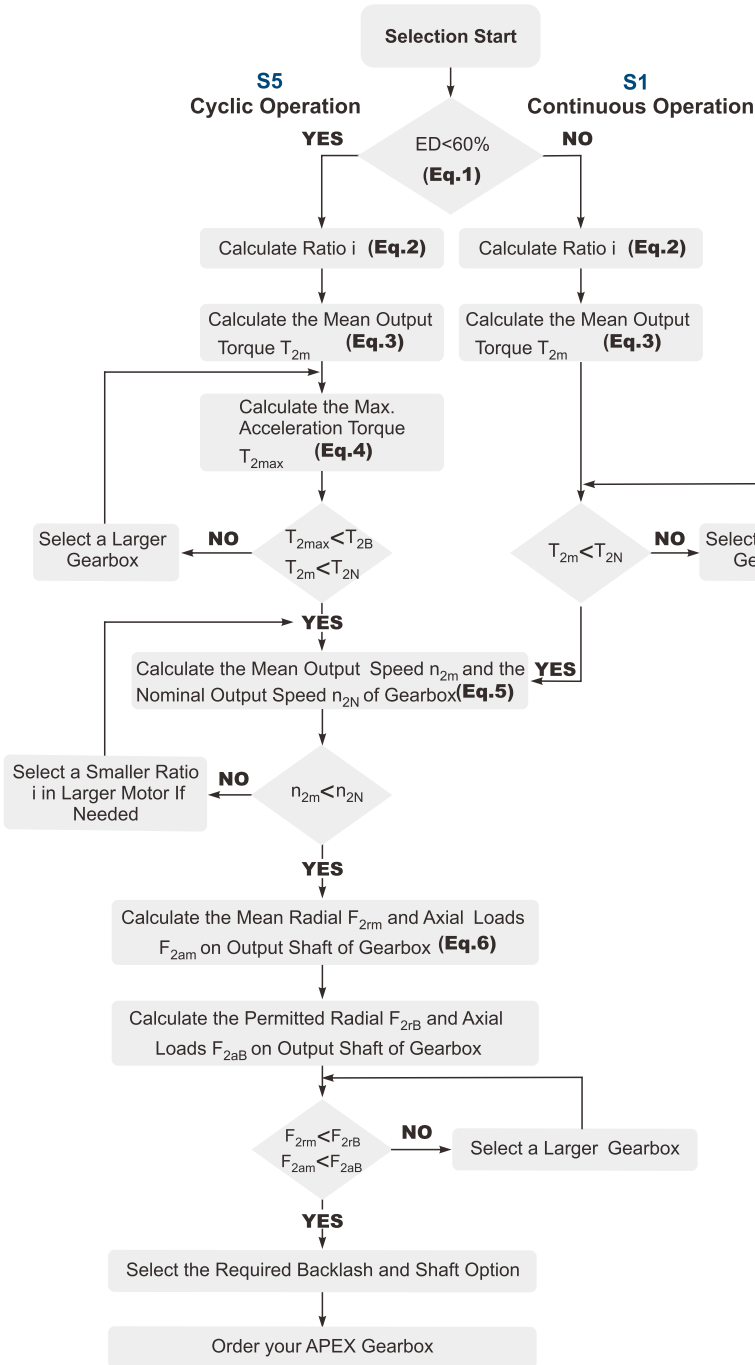

Recommended (for S5 Cycle Operation)

The general design is given for

$$\frac{J_L}{i^2} \leq 4 \times J_m$$

The optimal design is given for

$$\frac{J_L}{i^2} \cong J_m$$

J_L Load Inertia

J_m Motor Inertia

Liability Disclaimer:

APEX DYNAMICS, INC. endeavors to ensure the accuracy and reliability of the data in catalog.

APEX accepts no liability, whether in any form, for any loss or damage arising from any inaccuracy or omissions of this catalog.

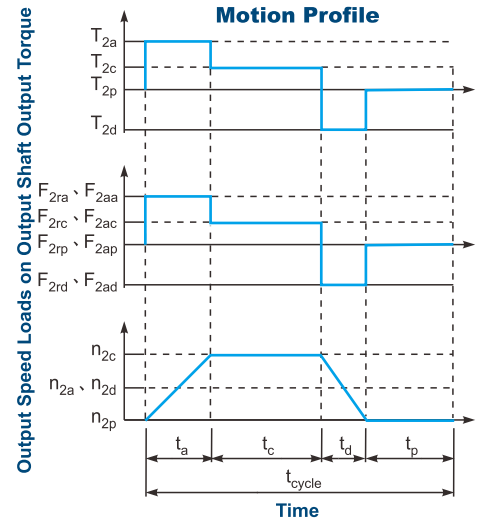

$$1. ED = \frac{t_a + t_c + t_d}{t_{cycle}} \times 100\% .$$

Index : a. Acceleration, c. Constant, d. Deceleration, p. Pause (Eq. 1)

$$2. i \cong \frac{n_m}{n_{work}}$$

n_m Output Speed of the Motor
 n_{work} Working Speed (Eq. 2)

$$3. T_{2m} = 3 \sqrt{\frac{n_{2a} \times t_a \times T_{2a}^3 + n_{2c} \times t_c \times T_{2c}^3 + n_{2d} \times t_d \times T_{2d}^3}{n_{2a} \times t_a + n_{2c} \times t_c + n_{2d} \times t_d}}$$

(Eq. 3)

$$4. T_{2max} = T_{mB} \times i \times K_s \times \eta$$

where K_s is

K_s	No. of Cycles / hr
1.0	0 ~ 1,000
1.1	1,000 ~ 1,500
1.3	1,500 ~ 2,000
1.6	2,000 ~ 3,000
1.8	3,000 ~ 5,000

T_{mB} Max. Output Torque of the Motor
 η Efficiency of the Gearbox (Eq. 4)

$$5. n_{2a} = n_{2d} = \frac{1}{2} \times n_{2c}$$

$$n_{2m} = \frac{n_{2a} \times t_a + n_{2c} \times t_c + n_{2d} \times t_d}{t_a + t_c + t_d}$$

$$n_{2N} = \frac{n_{1N}}{i}$$

(Eq. 5)

$$6. F_{2rm} = 3 \sqrt{\frac{n_{2a} \times t_a \times F_{2ra}^3 + n_{2c} \times t_c \times F_{2rc}^3 + n_{2d} \times t_d \times F_{2rd}^3}{n_{2a} \times t_a + n_{2c} \times t_c + n_{2d} \times t_d}}$$

$$F_{2am} = 3 \sqrt{\frac{n_{2a} \times t_a \times F_{2aa}^3 + n_{2c} \times t_c \times F_{2ac}^3 + n_{2d} \times t_d \times F_{2ad}^3}{n_{2a} \times t_a + n_{2c} \times t_c + n_{2d} \times t_d}}$$

(Eq. 6)

Permitted Radial and Axial Loads

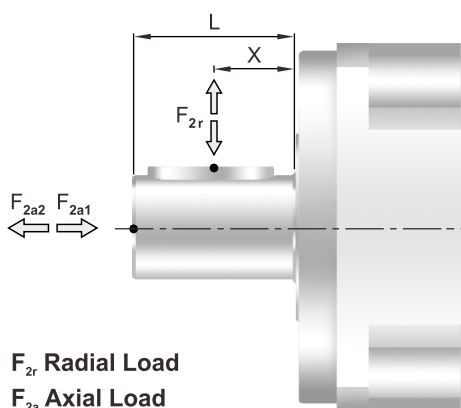

The permitted radial and axial loads on output shaft of the gearbox depend on the design of the gearbox supporting bearings.

APEX use the extension straddle oversized ball bearing design. It can take heavy load from both axes.

F_{2r} Radial Load
 F_{2a} Axial Load

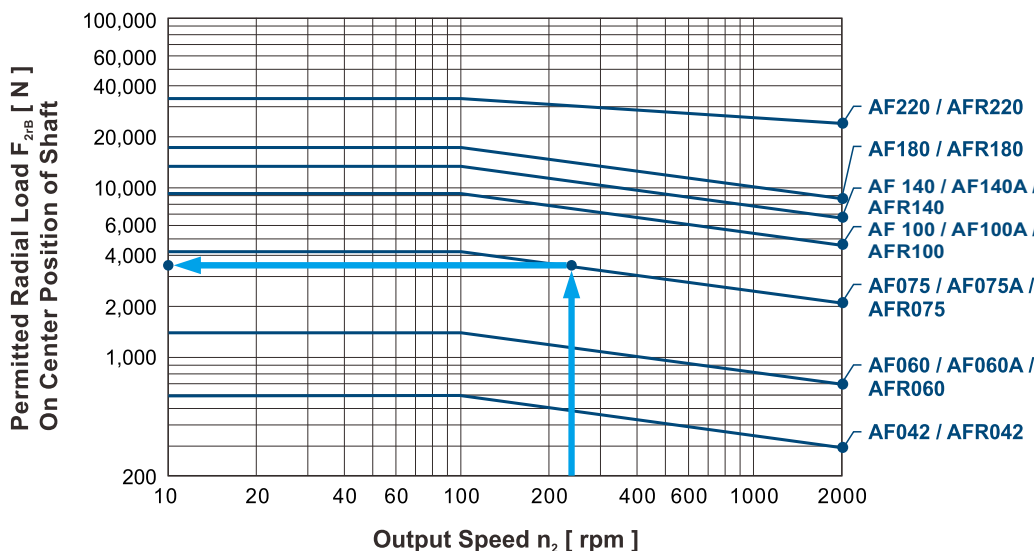

If radial force F_{2r} is exerted on the center of the output shaft $X=1/2 \times L$. The permitted radial load is given on left diagram.

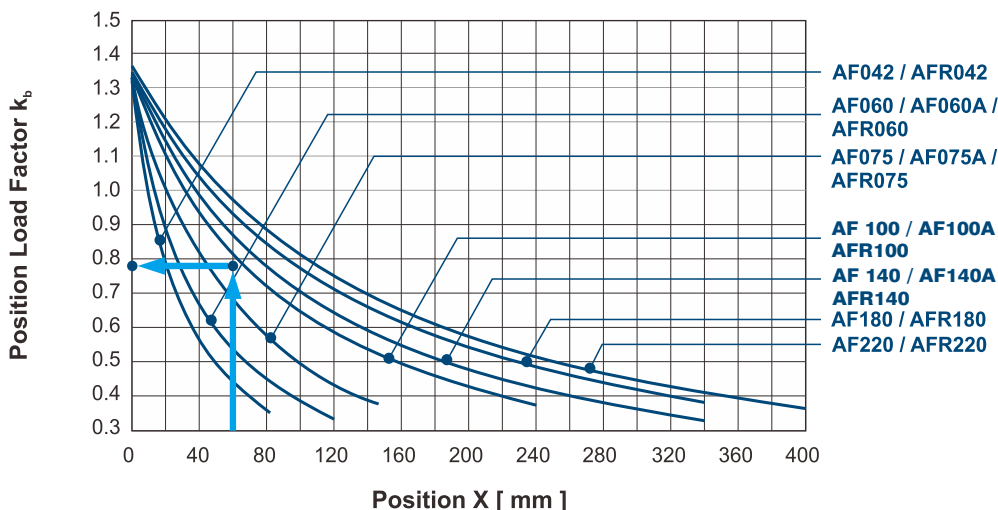

If radial force F_{2r} is not exerted on the center of the output shaft $X < 1/2 \times L$ or $X > 1/2 \times L$. The permitted radial and axial loads can be calculated by the position load factor k_b on the left diagram.