

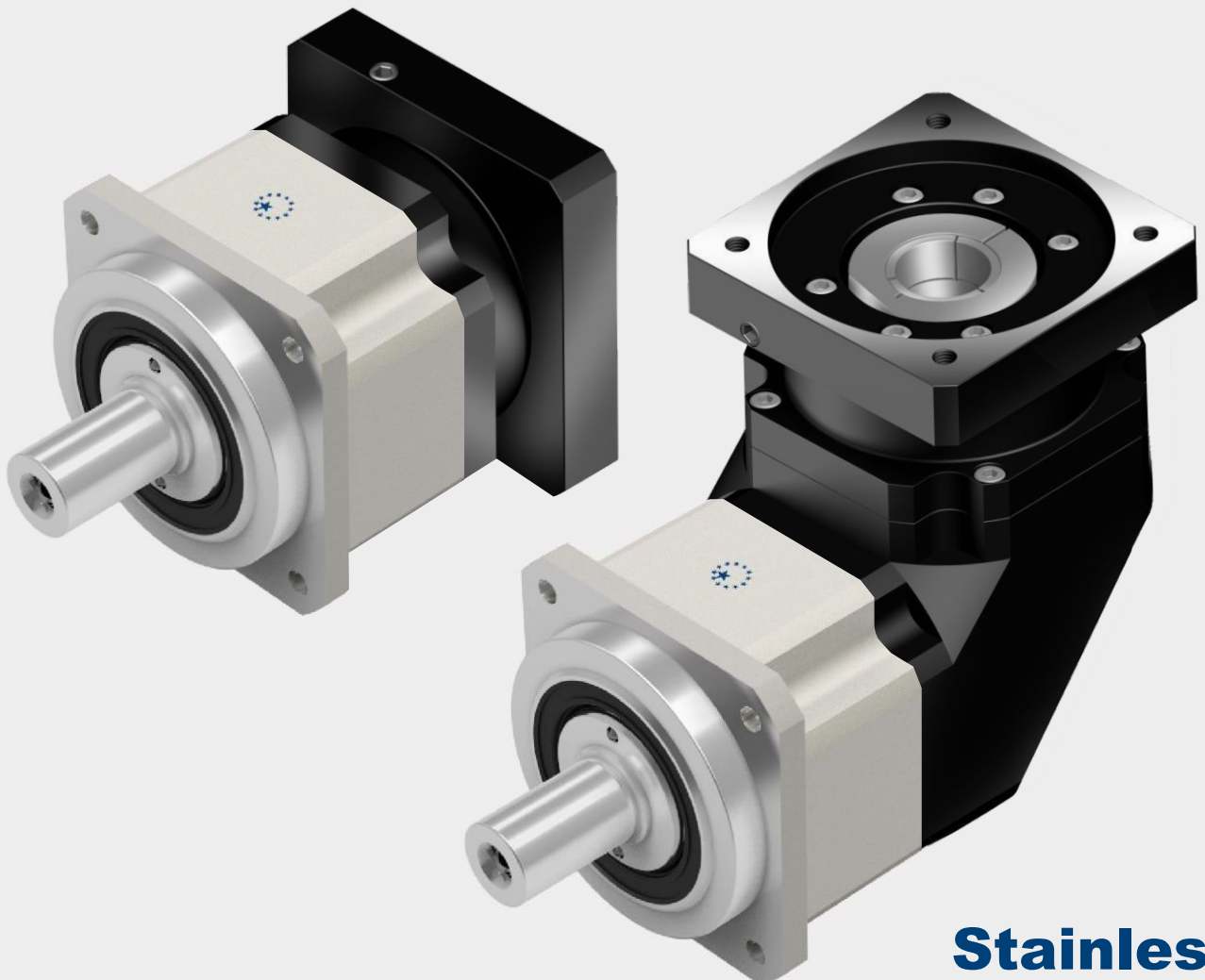

**APEX DYNAMICS, INC.**

**HIGH PRECISION  
PLANETARY GEARBOX**

**AB / ABR Series**



**Stainless**



**Apex Dynamics, Inc.** is the world's most productive manufacturer of servomotor drive planetary gearboxes for precision automation machinery. From our 800,000+ square foot ISO 9001:2008 manufacturing facility, based in Taichung, Taiwan, we manufacture to stock using the newest precision machine tools and quality test and inspection equipment. Complete focus on quality and precision allows us to produce our high quality gearheads at precision levels down to less than 1 arc minute (1/60 th of a degree), with consistency and high reliability.

Based on more than twenty years of accumulated manufacturing and marketing experience, plus the highest level of technical production capabilities, Apex Dynamics, Inc. designs and builds technically advanced, high speed, low backlash servo application planetary gearboxes. Our Break through patented technology (over 6 patents), provides the customer with the optimum high precision helical reducer at a reasonable price. We are continuously improving processes, finding proper and effective methods to provide customers new solutions for difficult applications, and developing new products.

The primary focus in daily operation is quality. We pride ourselves on our dedication to quality; our duty - is customer satisfaction.



**APEX**

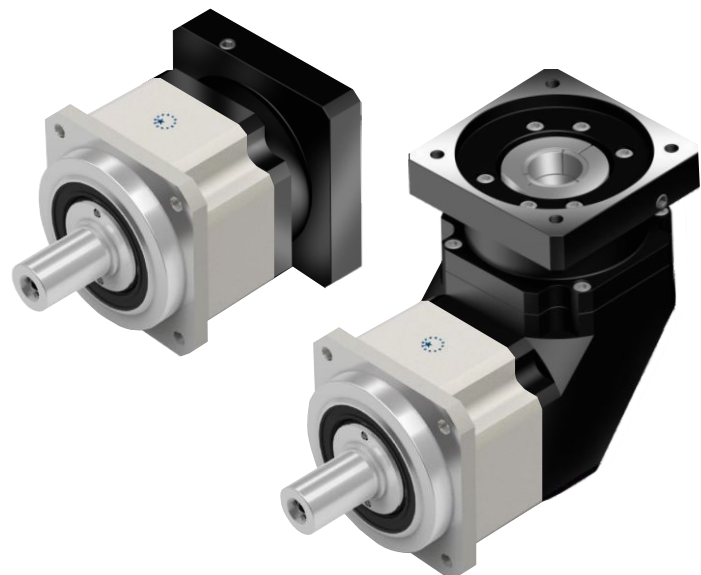

# AB Series

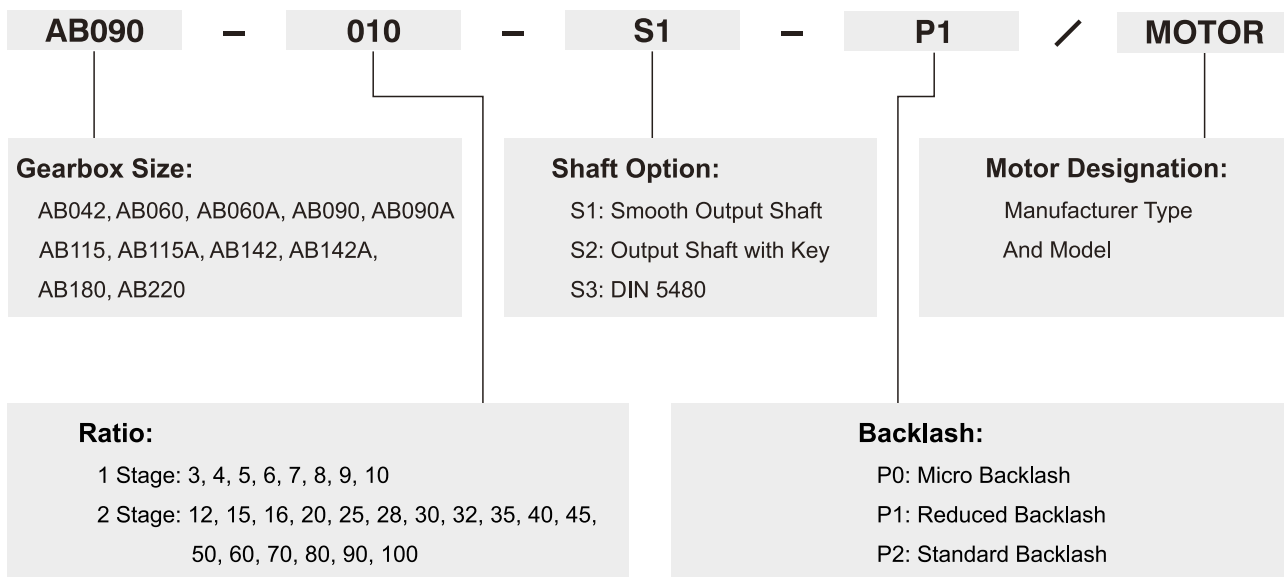

**Ordering Example: AB090-010-S1-P1 / SIEMENS 1FT6 041-4AF71**

# ABR Series

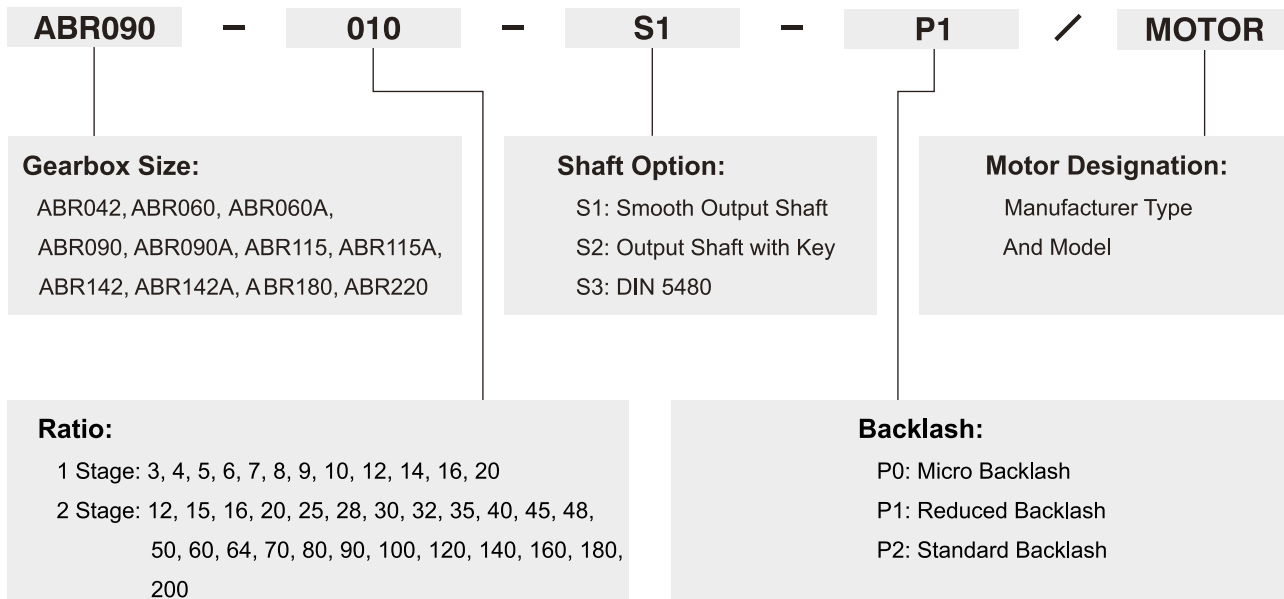

**Ordering Example: ABR090-010-S1-P1 / SIEMENS 1FT6 041-4AF71**



©2019 by APEX DYNAMICS, INC.  
 APEX DYNAMICS, INC. reserves modification and copyrights of all technical specifications, illustrations and drawings in this catalog in allowance for continuous products development and advancement.  
 For the newest data and information, please visit <http://www.apexdyna.com/>

# Specifications / AB Series

## Gearbox Performance

Model No.		Stage	Ratio <sup>(1)</sup>	AB042	AB060	AB060A	AB090	AB090A	AB115	AB115A	AB142	AB142A	AB180	AB220	
Nominal Output Torque $T_{2N}$	Nm	1	3	20	55	-	130	-	208	-	342	-	588	1,140	
			4	19	50	-	140	-	290	-	542	-	1,050	1,700	
			5	22	60	-	160	-	330	-	650	-	1,200	2,000	
			6	20	55	-	150	-	310	-	600	-	1,100	1,900	
			7	19	50	-	140	-	300	-	550	-	1,100	1,800	
			8	17	45	-	120	-	260	-	500	-	1,000	1,600	
			9	14	40	-	100	-	230	-	450	-	900	1,500	
			10	14	40	-	100	-	230	-	450	-	900	1,500	
			2	12	19	50	50	140	140	290	290	542	542	1,050	1,700
				15	20	55	55	130	130	208	208	342	342	588	1,140
		16		19	50	50	140	140	290	290	542	542	1,050	1,700	
		20		19	50	50	140	140	290	290	542	542	1,050	1,700	
		25		22	60	60	160	160	330	330	650	650	1,200	2,000	
		28		19	50	50	140	140	300	300	550	550	1,100	1,800	
		30		20	55	55	150	150	310	310	600	600	1,100	1,900	
		32		17	45	45	120	120	260	260	500	500	1,000	1,600	
		35		19	50	50	140	140	300	300	550	550	1,100	1,800	
		40		17	45	45	120	120	260	260	500	500	1,000	1,600	
		45	14	40	40	100	100	230	230	450	450	900	1,500		
		50	22	60	60	160	160	330	330	650	650	1,200	2,000		
60	20	55	55	150	150	310	310	600	600	1,100	1,900				
70	19	50	50	140	140	300	300	550	550	1,100	1,800				
80	17	45	45	120	120	260	260	500	500	1,000	1,600				
90	14	40	40	100	100	230	230	450	450	900	1,500				
100	14	40	40	100	100	230	230	450	450	900	1,500				
Emergency Stop Torque $T_{2NOT}^{(2)}$	Nm	1,2	3~100	3 times of Nominal Output Torque											
Nominal Input Speed $n_{1N}$	rpm	1,2	3~100	5,000	5,000	5,000	4,000	4,000	4,000	4,000	3,000	3,000	3,000	2,000	
Max. Input Speed $n_{1B}$	rpm	1,2	3~100	10,000	10,000	10,000	8,000	8,000	8,000	8,000	6,000	6,000	6,000	4,000	
Micro Backlash P0	arcmin	1	3~10	-	-	-	≤1	-	≤1	-	≤1	-	≤1	≤1	
		2	12~100	-	-	-	-	-	≤3	≤3	≤3	≤3	≤3	≤3	
Reduced Backlash P1	arcmin	1	3~10	≤3	≤3	-	≤3	-	≤3	-	≤3	-	≤3	≤3	
		2	12~100	≤5	≤5	≤5	≤5	≤5	≤5	≤5	≤5	≤5	≤5	≤5	
Standard Backlash P2	arcmin	1	3~10	≤5	≤5	-	≤5	-	≤5	-	≤5	-	≤5	≤5	
		2	12~100	≤7	≤7	≤7	≤7	≤7	≤7	≤7	≤7	≤7	≤7	≤7	
Torsional Rigidity	Nm/arcmin	1,2	3~100	3	7	7	14	14	25	25	50	50	145	225	
Max. Radial Load $F_{2RB}^{(3)}$	N	1,2	3~100	780	1,530	1,530	3,250	3,250	6,700	6,700	9,400	9,400	14,500	50,000	
Max. Axial Load $F_{2aB}^{(3)}$	N	1,2	3~100	390	765	765	1,625	1,625	3,350	3,350	4,700	4,700	7,250	25,000	
Max. Tilting Moment $M_{2K}$	Nm	1,2	3~100	25	70	70	200	200	550	550	990	990	1,760	7,630	
Efficiency $\eta$	%	1	3~10	≥97%											
		2	12~100	≥94%											
Weight	kg	1	3~10	0.6	1.3	-	3.7	-	7.8	-	13	-	26	45	
		2	12~100	0.8	1.5	1.9	4.1	5.3	9	11.4	17.5	20.7	32	57	
Operating Temp	°C	1,2	3~100	-10°C~90°C											
Lubrication		1,2	3~100	Synthetic lubrication oils											
Degree of Gearbox Protection		1,2	3~100	IP65											
Mounting Position		1,2	3~100	all directions											
Noise <sup>(4)</sup>	dB(A)	1,2	3~100	≤56	≤58	≤60	≤60	≤63	≤63	≤65	≤65	≤67	≤67	≤70	

(1) Ratio ( $i=N_{in}/N_{out}$ )

(2) Max. acceleration torque  $T_{2B} = 60\%$  of  $T_{2NOT}$

(3) Applied to the output shaft center at 100 rpm

(4) The dB values are measured by gearbox with ratio 10 (1-stage) or ratio 100 (2-stage), no loading at 3,000 RPM or at the respective Nominal Input Speed by bigger model size.

By lower ratio and/or higher RPM, the noise level could be 3 to 5 dB higher.

# Max. Tilting Moment $M_{2K}$

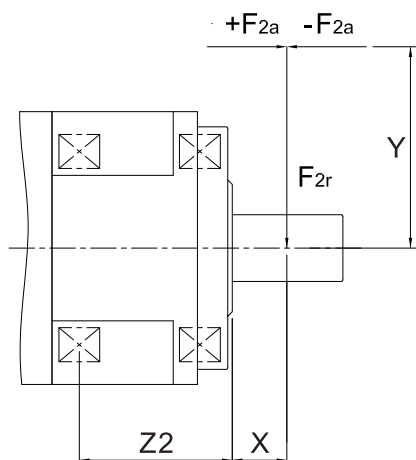

$$M_{2K} = \frac{F_{2a} * Y + F_{2r} * (X+Z2)}{1000}$$

$M_{2K}$  : [Nm]  
 $F_{2a}, F_{2r}$  : [N]  
 $X, Y, Z2$  : [mm]

AB / ABR	042	060	090	115	142	180	220
Z2 [mm]	31	42	56.5	71.5	85.5	102.5	127.1

Note : Applied to the output shaft center at 100 rpm.

## Gearbox Inertia

Model No.	Stage	Ratio <sup>A</sup>	AB042	AB060	AB060A	AB090	AB090A	AB115	AB115A	AB142	AB142A	AB180	AB220	
Mass Moments of Inertia $J_1$	1	3	0.03	0.16	-	0.61	-	3.25	-	9.21	-	28.98	69.61	
		4	0.03	0.14	-	0.48	-	2.74	-	7.54	-	23.67	54.37	
		5	0.03	0.13	-	0.47	-	2.71	-	7.42	-	23.29	53.27	
		6	0.03	0.13	-	0.45	-	2.65	-	7.25	-	22.75	51.72	
		7	0.03	0.13	-	0.45	-	2.62	-	7.14	-	22.48	50.97	
		8	0.03	0.13	-	0.44	-	2.58	-	7.07	-	22.59	50.84	
		9	0.03	0.13	-	0.44	-	2.57	-	7.04	-	22.53	50.63	
		10	0.03	0.13	-	0.44	-	2.57	-	7.03	-	22.51	50.56	
		12	0.03	0.03	0.16	0.16	0.61	0.61	3.25	3.25	9.21	9.21	28.98	69.61
		15	0.03	0.03	0.13	0.13	0.47	0.47	2.71	2.71	7.42	7.42	23.29	53.27
	2	16	0.03	0.03	0.14	0.14	0.48	0.48	2.74	2.74	7.54	7.54	23.67	54.37
		20	0.03	0.03	0.13	0.13	0.47	0.47	2.71	2.71	7.42	7.42	23.29	53.27
		25	0.03	0.03	0.13	0.13	0.47	0.47	2.71	2.71	7.42	7.42	23.29	53.27
		28	0.03	0.03	0.14	0.14	0.48	0.48	2.74	2.74	7.54	7.54	23.67	54.37
		30	0.03	0.03	0.13	0.13	0.47	0.47	2.71	2.71	7.42	7.42	23.29	53.27
		32	0.03	0.03	0.14	0.14	0.48	0.48	2.74	2.74	7.54	7.54	23.67	54.37
		35	0.03	0.03	0.13	0.13	0.47	0.47	2.71	2.71	7.42	7.42	23.29	53.27
		40	0.03	0.03	0.13	0.13	0.47	0.47	2.71	2.71	7.42	7.42	23.29	53.27
		45	0.03	0.03	0.13	0.13	0.47	0.47	2.71	2.71	7.42	7.42	23.29	53.27
		50	0.03	0.03	0.13	0.13	0.44	0.44	2.57	2.57	7.03	7.03	22.51	50.56
60	0.03	0.03	0.13	0.13	0.44	0.44	2.57	2.57	7.03	7.03	22.51	50.56		
70	0.03	0.03	0.13	0.13	0.44	0.44	2.57	2.57	7.03	7.03	22.51	50.56		
80	0.03	0.03	0.13	0.13	0.44	0.44	2.57	2.57	7.03	7.03	22.51	50.56		
90	0.03	0.03	0.13	0.13	0.44	0.44	2.57	2.57	7.03	7.03	22.51	50.56		
100	0.03	0.03	0.13	0.13	0.44	0.44	2.57	2.57	7.03	7.03	22.51	50.56		

# Dimensions (1-stage, Ratio $i=3\sim 10$ ) / AB Series

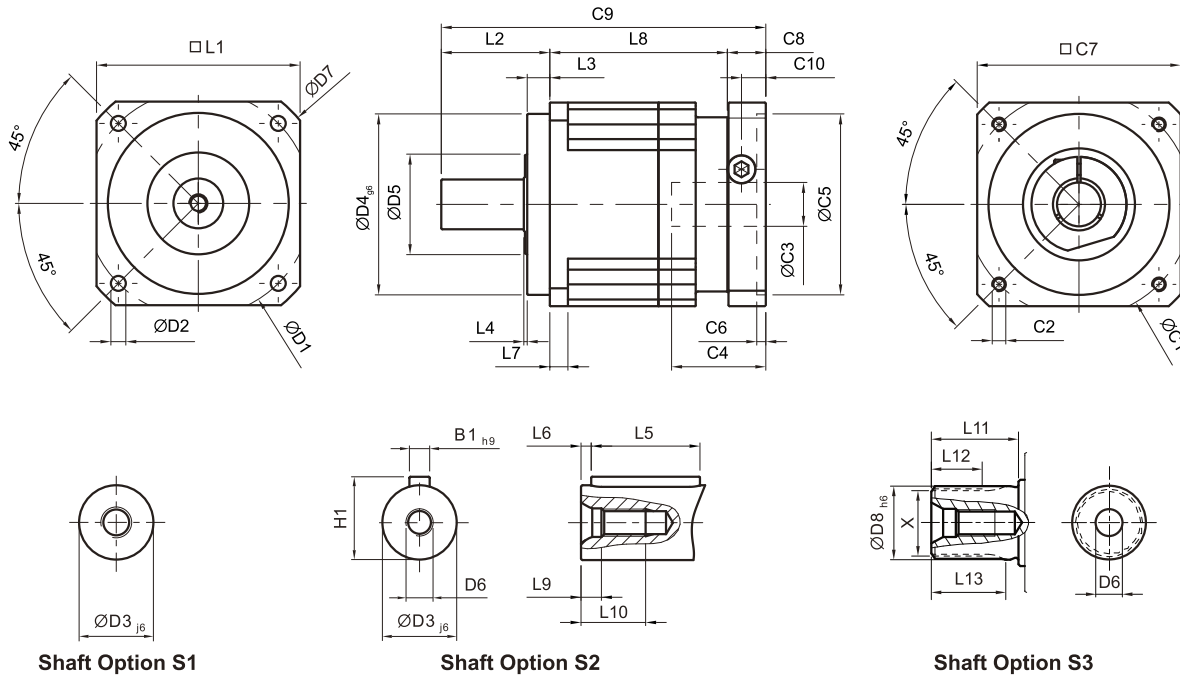

Shaft Option S1

Shaft Option S2

Shaft Option S3

[unit: mm]

Dimension	AB042	AB060	AB090	AB115	AB142	AB180	AB220
D1	50	70	100	130	165	215	250
D2	3.4	5.5	6.6	9	11	13	17
D3 <sub>j6</sub>	13	16	22	32	40	55	75
D4 <sub>g6</sub>	35	50	80	110	130	160	180
D5	22	45	65	95	75	95	115
D6	M4 x 0.7P	M5 x 0.8P	M8 x 1.25P	M12 x 1.75P	M16 x 2P	M20 x 2.5P	M20 x 2.5P
D7	56	80	116	152	185	240	292
D8 <sub>h6</sub>	-	16	22	32	40	55	75
L1	42	60	90	115	142	180	220
L2	26	37	48	65	97	105	138
L3	5.5	7	10	12	15	20	30
L4	1	1.5	1.5	2	3	3	3
L5	16	25	32	40	63	70	90
L6	2	2	3	5	5	6	7
L7	4	6	8	10	12	15	20
L8	31	61	78.5	102	119.5	154	163.5
L9	4.5	4.8	7.2	10	12	15	15
L10	10	12.5	19	28	36	42	42
L11	-	26	26	26	40	41.5	52
L12	-	15	15	15	20	21.5	28
L13	-	21	22.5	23	33.5	33.5	45
C1 <sup>1</sup>	46	70	100	130	165	215	235
C2 <sup>1</sup>	M4 x 0.7P	M5 x 0.8P	M6 x 1P	M8 x 1.25P	M10 x 1.5P	M12 x 1.75P	M12 x 1.75P
C3 <sup>1</sup>	≤11 / ≤12 <sup>2</sup>	≤14 / ≤16 <sup>2</sup>	≤19 / ≤24 <sup>2</sup>	≤32	≤38	≤48	≤55
C4 <sup>1</sup>	25	34	40	50	60	85	116
C5 <sup>1</sup>	30	50	80	110	130	180	200
C6 <sup>1</sup>	3.5	8	4	5	6	6	6
C7 <sup>1</sup>	42	60	90	115	142	190	220
C8 <sup>1</sup>	29.5	19	17	19.5	22.5	29	63
C9 <sup>1</sup>	86.5	117	143.5	186.5	239	288	364.5
C10 <sup>1</sup>	8.75	13.5	10.75	13	15	20.75	53
B1 <sub>h9</sub>	5	5	6	10	12	16	20
H1	15	18	24.5	35	43	59	79.5
X DIN5480	-	W16x0.8x 30x18x6m	W22x1.25x 30x16x6m	W32x1.25x 30x24x6m	W40x2x 30x18x6m	W55x2x 30x26x6m	W70x2x 30x34x6m

1. C1~C10 are motor specific dimensions (metric std shown). Refer to [www.apexdyna.com](http://www.apexdyna.com) and Design Tool to view your specific motor mounting system.  
 2. AB042M1 ratio 5, 10 offers C3 ≤ 12 option; AB060M1 ratio 5, 10 offers C3 ≤ 16 option; AB090M1 offers C3 ≤ 24 option.



# Dimensions (2-stage, Ratio i=12~100) / AB Series

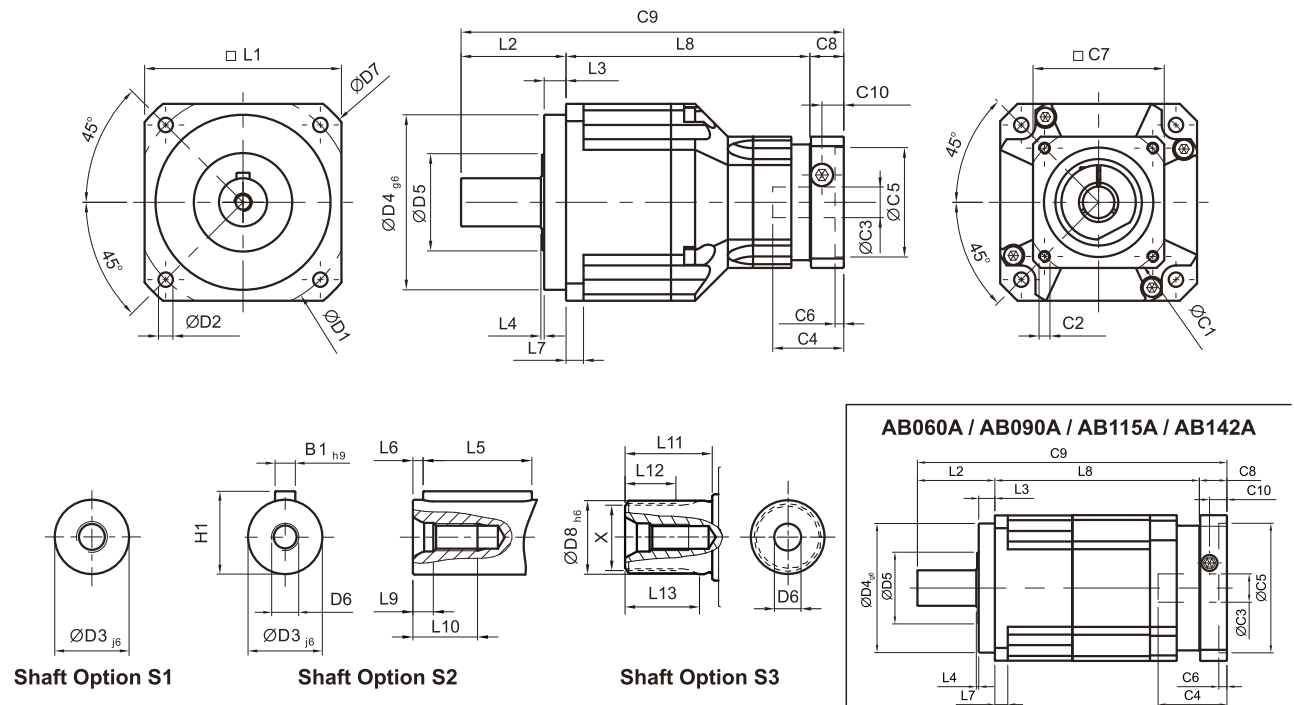

[unit: mm]

Dimension	AB042	AB060	AB060A	AB090	AB090A	AB115	AB115A	AB142	AB142A	AB180	AB220
D1	50	70		100		130		165	215	250	
D2	3.4	5.5		6.6		9		11	13	17	
D3 <sub>j6</sub>	13	16		22		32		40	55	75	
D4 <sub>g6</sub>	35	50		80		110		130	160	180	
D5	22	45		65		95		75	95	115	
D6	M4 x 0.7P	M5 x 0.8P		M8 x 1.25P		M12 x 1.75P		M16 x 2P	M20 x 2.5P	M20 x 2.5P	
D7	56	80		116		152		185	240	292	
D8 <sub>h6</sub>	-	16		22		32		40	55	75	
L1	42	60		90		115		142	180	220	
L2	26	37		48		65		97	105	138	
L3	5.5	7		10		12		15	20	30	
L4	1	1.5		1.5		2		3	3	3	
L5	16	25		32		40		63	70	90	
L6	2	2		3		5		5	6	7	
L7	4	6		8		10		12	15	20	
L8	58.5	72	98	111.5	126.5	143.5	163	176	191	209.5	248
L9	4.5	4.8		7.2		10		12	15	15	
L10	10	12.5		19		28		36	42	42	
L11	-	26		26		26		40	41.5	52	
L12	-	15		15		15		20	21.5	28	
L13	-	21		22.5		23		33.5	33.5	45	
C1 <sup>3</sup>	46	46	70	70	100	100	130	130	165	165	215
C2 <sup>3</sup>	M4 x 0.7P	M4 x 0.7P	M5 x 0.8P	M5 x 0.8P	M6 x 1P	M6 x 1P	M8 x 1.25P	M8 x 1.25P	M10 x 1.5P	M10 x 1.5P	M12 x 1.75P
C3 <sup>3</sup>	≤11 / ≤12 <sup>4</sup>	≤11 / ≤12 <sup>4</sup>	≤14 / ≤16 <sup>4</sup>	≤14 / ≤15.875 / ≤16 <sup>4</sup>	≤19 / ≤24 <sup>4</sup>	≤19 / ≤24 <sup>4</sup>	≤32	≤32	≤38	≤38	≤48
C4 <sup>3</sup>	25	25	34	34	40	40	50	50	60	60	85
C5 <sup>3</sup>	30	30	50	50	80	80	110	110	130	130	180
C6 <sup>3</sup>	3.5	3.5	8	8	4	4	5	5	6	6	6
C7 <sup>3</sup>	42	42	60	60	90	90	115	115	142	142	190
C8 <sup>3</sup>	29.5	29.5	19	19	17	17	19.5	19.5	22.5	22.5	29
C9 <sup>3</sup>	114	138.5	154	178.5	191.5	225.5	247.5	292.5	310.5	337	415
C10 <sup>3</sup>	8.75	8.75	13.5	13.5	10.75	10.75	13	13	15	15	20.75
B1 <sub>h9</sub>	5	5		6		10		12	16	20	
H1	15	18		24.5		35		43	59	79.5	
X DIN5480	-	W16x0.8x 30x18x6m		W22x1.25x 30x16x6m		W32x1.25x 30x24x6m		W40x2x 30x18x6m	W55x2x 30x26x6m	W70x2x 30x34x6m	

3. C1~C10 are motor specific dimensions (metric std shown). Refer to [www.apexdyna.com](http://www.apexdyna.com) and Design Tool to view your specific motor mounting system.  
 4. AB042M1 offers C3 ≤ 12 option; AB060/A M1 offers C3 ≤ 12/16 option; AB090/A M1 offers C3 ≤ 16/24 option; AB090 M2 offers C3 ≤ 15.875.  
 AB115M1 offers C3 ≤ 24 option.

# Specifications / ABR Series

## Gearbox Performance

Model No.		Stage	Ratio <sup>(1)</sup>	ABR042	ABR060	ABR060A	ABR090	ABR090A	ABR115	ABR115A	ABR142	ABR142A	ABR180	ABR220	
Nominal Output Torque $T_{2N}$	Nm	1	3	9	36	-	90	-	195	-	342	-	588	1,140	
			4	12	48	-	120	-	260	-	520	-	1,040	1,680	
			5	15	60	-	150	-	325	-	650	-	1,200	2,000	
			6	18	55	-	150	-	310	-	600	-	1,100	1,900	
			7	19	50	-	140	-	300	-	550	-	1,100	1,800	
			8	17	45	-	120	-	260	-	500	-	1,000	1,600	
			9	14	40	-	100	-	230	-	450	-	900	1,500	
			10	14	60	-	150	-	325	-	650	-	1,200	2,000	
			12	-	55	-	150	-	310	-	600	-	1,100	1,900	
			14	-	42	-	140	-	300	-	550	-	1,100	1,800	
		16	-	45	-	120	-	260	-	500	-	1,000	1,600		
		20	-	40	-	100	-	230	-	450	-	900	1,500		
		12	12	-	-	-	-	-	-	-	-	-	-	-	-
		15	14	-	-	-	-	-	-	-	-	-	-	-	-
		16	15	-	-	-	-	-	-	-	-	-	-	-	-
		20	14	-	-	-	-	-	-	-	-	-	-	-	-
		25	15	60	60	150	150	325	325	650	650	1,200	2,000		
		28	19	50	50	140	140	300	300	550	550	1,100	1,800		
		30	20	55	55	150	150	310	310	600	600	1,100	1,900		
		32	17	45	45	120	120	260	260	500	500	1,000	1,600		
		35	19	50	50	140	140	300	300	550	550	1,100	1,800		
		40	17	45	45	120	120	260	260	500	500	1,000	1,600		
		45	14	40	40	100	100	230	230	450	450	900	1,500		
		48	-	-	55	150	150	310	310	600	600	1,100	1,900		
		50	14	60	60	150	150	325	325	650	650	1,200	2,000		
		60	20	55	55	150	150	310	310	600	600	1,100	1,900		
		64	-	-	45	120	120	260	260	500	500	1,000	1,600		
		70	19	50	50	140	140	300	300	550	550	1,100	1,800		
		80	17	45	45	120	120	260	260	500	500	1,000	1,600		
		90	14	40	40	100	100	230	230	450	450	900	1,500		
		100	14	40	60	150	150	325	325	650	650	1,200	2,000		
		120	-	-	55	150	150	310	310	600	600	1,100	1,900		
140	-	-	50	140	140	300	300	550	550	1,100	1,800				
160	-	-	45	120	120	260	260	500	500	1,000	1,600				
180	-	-	40	100	100	230	230	450	450	900	1,500				
200	-	-	40	100	100	230	230	450	450	900	1,500				
Emergency Stop Torque $T_{2B}$ <sup>(2)</sup>	Nm	1,2	3~200	3 times of Nominal Output Torque											
Nominal Input Speed $n_{1N}$	rpm	1,2	3~200	5,000	5,000	5,000	4,000	4,000	4,000	4,000	3,000	3,000	3,000	2,000	
Max. Input Speed $n_{1B}$	rpm	1,2	3~200	10,000	10,000	10,000	8,000	8,000	8,000	8,000	6,000	6,000	6,000	4,000	
Micro Backlash P0	arcmin	1	3~20	-	-	-	≤2	-	≤2	-	≤2	-	≤2	≤2	
		2	12~200	-	-	-	≤4	≤4	≤4	≤4	≤4	≤4	≤4	≤4	
Reduced Backlash P1	arcmin	1	3~20	≤4	≤4	-	≤4	-	≤4	-	≤4	-	≤4	≤4	
		2	12~200	≤7	≤7	≤7	≤7	≤7	≤7	≤7	≤7	≤7	≤7	≤7	
Standard Backlash P2	arcmin	1	3~20	≤6	≤6	-	≤6	-	≤6	-	≤6	-	≤6	≤6	
		2	12~200	≤9	≤9	≤9	≤9	≤9	≤9	≤9	≤9	≤9	≤9	≤9	
Torsional Rigidity	Nm/arcmin	1,2	3~200	3	7	7	14	14	25	25	50	50	145	225	
Max. Radial Load $F_{2B}$ <sup>(3)</sup>	N	1,2	3~200	780	1,530	1,530	3,250	3,250	6,700	6,700	9,400	9,400	14,500	50,000	
Max. Axial Load $F_{2AB}$ <sup>(3)</sup>	N	1,2	3~200	390	765	765	1,625	1,625	3,350	3,350	4,700	4,700	7,250	25,000	
Max. Tilting Moment $M_{2K}$	Nm	1,2	3~200	25	70	70	200	200	550	550	990	990	1,760	7,630	
Efficiency $\eta$	%	1	3~20	≥95%											
		2	12~200	≥92%											
Weight	kg	1	3~20	0.9	2.1	-	6.4	-	12.1	-	23	-	44.5	77	
		2	12~200	1.2	1.8	2.7	4.8	7.9	11.5	15.9	21.5	29.6	41.5	75	
Operating Temp	°C	1,2	3~200	-10°C~+90°C											
Lubrication		1,2	3~200	Synthetic lubrication oils											
Degree of Gearbox Protection		1,2	3~200	IP65											
Mounting Position		1,2	3~200	all directions											
Noise <sup>(4)</sup>	dB(A)	1,2	3~200	≤61	≤63	≤65	≤65	≤68	≤68	≤70	≤70	≤72	≤72	≤74	

(1) Ratio ( $i = N_{in} / N_{out}$ )

(2) Max. acceleration torque  $T_{2B} = 60\%$  of  $T_{2NOT}$

(3) Applied to the output shaft center at 100 rpm

(4) The dB values are measured by gearbox with ratio 10 (1-stage) or ratio 100 (2-stage), no loading at 3,000 RPM or at the respective Nominal Input Speed by bigger model size.

By lower ratio and/or higher RPM, the noise level could be 3 to 5 dB higher.



## Gearbox Inertia

Model No.		Stage	Ratio	ABR042	ABR060	ABR060A	ABR090	ABR090A	ABR115	ABR115A	ABR142	ABR142A	ABR180	ABR220	
Mass Moments of Inertia J,	kg · cm <sup>2</sup>	1	3~10	0.09	0.35	-	2.25	-	6.84	-	23.4	-	68.9	135.4	
			12~20	-	0.31	-	1.87	-	6.25	-	21.8	-	65.6	119.8	
		2	12~20	0.09	-	-	-	-	-	-	-	-	-	-	-
			25~90	0.09	0.09	0.35	0.35	2.25	2.25	6.84	6.84	23.4	23.4	68.9	
			48, 64	-	-	0.31	0.31	1.87	1.87	6.25	6.25	21.8	21.8	65.6	
			100~200	-	-	0.31	0.31	1.87	1.87	6.25	6.25	21.8	21.8	65.6	

# Dimensions (1-stage, Ratio $i=3\sim 20$ ) / ABR Series

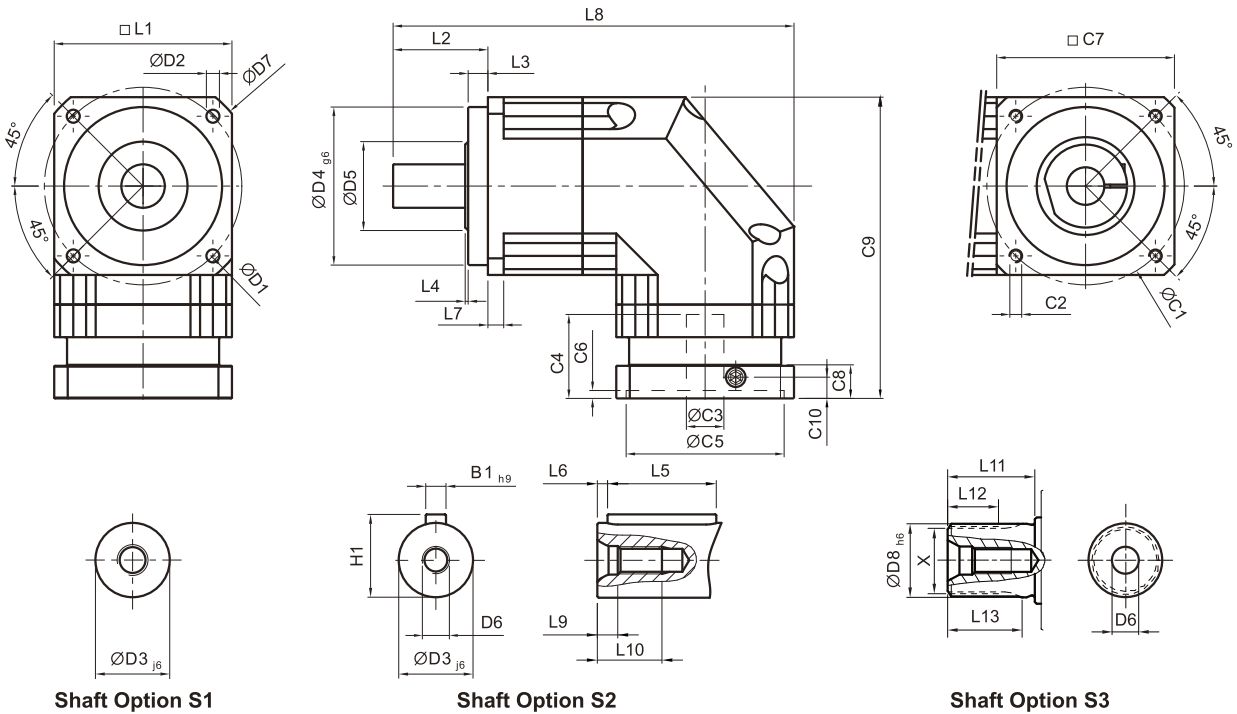

[unit: mm]

Dimension	ABR042	ABR060	ABR090	ABR115	ABR142	ABR180	ABR220
D1	50	70	100	130	165	215	250
D2	3.4	5.5	6.6	9	11	13	17
D3 j6	13	16	22	32	40	55	75
D4 g6	35	50	80	110	130	160	180
D5	22	45	65	95	75	95	115
D6	M4 x 0.7P	M5 x 0.8P	M8 x 1.25P	M12 x 1.75P	M16 x 2P	M20 x 2.5P	M20 x 2.5P
D7	56	80	116	152	185	240	292
D8 h6	-	16	22	32	40	55	75
L1	42	60	90	115	142	180	220
L2	26	37	48	65	97	105	138
L3	5.5	7	10	12	15	20	30
L4	1	1.5	1.5	2	3	3	3
L5	16	25	32	40	63	70	90
L6	2	2	3	5	5	6	7
L7	4	6	8	10	12	15	20
L8	111.5	145	203	259	333	394	484
L9	4.5	4.8	7.2	10	12	15	15
L10	10	12.5	19	28	36	42	42
L11	-	26	26	26	40	41.5	52
L12	-	15	15	15	20	21.5	28
L13	-	21	22.5	23	33.5	33.5	45
C1 <sup>1</sup>	46	70	100	130	165	215	235
C2 <sup>1</sup>	M4 x 0.7P	M5 x 0.8P	M6 x 1P	M8 x 1.25P	M10 x 1.5P	M12 x 1.75P	M12 x 1.75P
C3 <sup>1</sup>	$\leq 11 / \leq 12^2$	$\leq 14 / \leq 16^2$	$\leq 19 / \leq 24^2$	$\leq 32$	$\leq 38$	$\leq 48$	$\leq 55$
C4 <sup>1</sup>	25	34	40	50	60	85	116
C5 <sup>1</sup>	30	50	80	110	130	180	200
C6 <sup>1</sup>	3.5	8	4	5	6	6	6
C7 <sup>1</sup>	42	60	90	115	142	190	220
C8 <sup>1</sup>	29.5	19	17	19.5	22.5	29	63
C9 <sup>1</sup>	90.5	111.5	152.5	191.5	235.5	303.5	378.5
C10 <sup>1</sup>	8.75	13.5	10.75	13	15	20.75	53
B1 h9	5	5	6	10	12	16	20
H1	15	18	24.5	35	43	59	79.5
X DIN5480	-	W16x0.8x 30x18x6m	W22x1.25x 30x16x6m	W32x1.25x 30x24x6m	W40x2x 30x18x6m	W55x2x 30x26x6m	W70x2x 30x34x6m

1. C1~C10 are motor specific dimensions (metric std shown). Refer to [www.apexdyna.com](http://www.apexdyna.com) and Design Tool to view your specific motor mounting system.  
 2. ABR042M1 offers C3  $\leq 12$  option; ABR060M1 offers C3  $\leq 16$  option; ABR090M1 offers C3  $\leq 24$  option.

# Dimensions (2-stage, Ratio i=12~200) / ABR Series

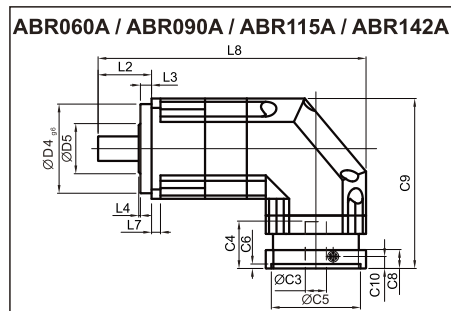
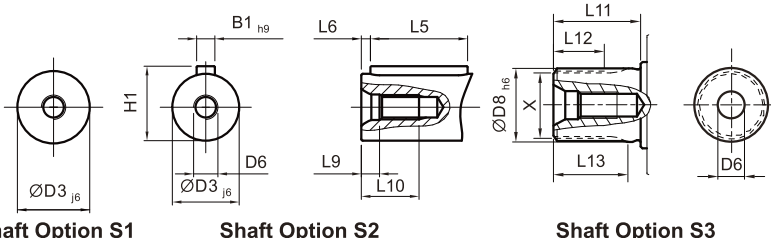
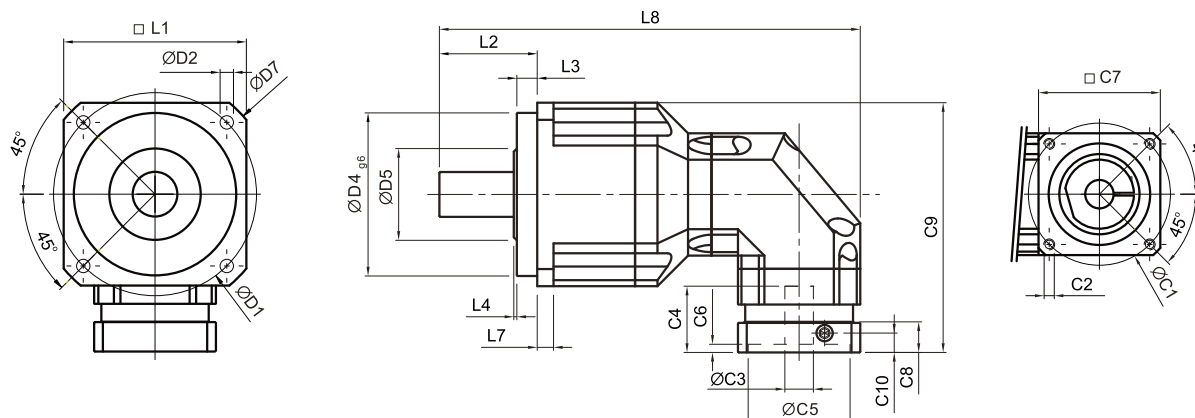

[unit: mm]

Dimension	ABR042	ABR060	ABR060A	ABR090	ABR090A	ABR115	ABR115A	ABR142	ABR142A	ABR180	ABR220
D1	50	70		100		130		165		215	250
D2	3.4	5.5		6.6		9		11		13	17
D3 <sub>j6</sub>	13	16		22		32		40		55	75
D4 <sub>g6</sub>	35	50		80		110		130		160	180
D5	22	45		65		95		75		95	115
D6	M4 x 0.7P	M5 x 0.8P		M8 x 1.25P		M12x1.75P		M16x2P		M20x2.5P	M20x2.5P
D7	56	80		116		152		185		240	292
D8 <sub>h6</sub>	-	16		22		32		40		55	75
L1	42	60		90		115		142		180	220
L2	26	37		48		65		97		105	138
L3	5.5	7		10		12		15		20	30
L4	1	1.5		1.5		2		3		3	3
L5	16	25		32		40		63		70	90
L6	2	2		3		5		5		6	7
L7	4	6		8		10		12		15	20
L8	139	163.5	182	206.5	251	285	320	365	404.5	431	521
L9	4.5	4.8		7.2		10		12		15	15
L10	10	12.5		19		28		36		42	42
L11	-	26		26		26		40		41.5	52
L12	-	15		15		15		20		21.5	28
L13	-	21		22.5		23		33.5		33.5	45
C1 <sup>3</sup>	46	46	70	70	100	100	130	130	165	165	215
C2 <sup>3</sup>	M4 x 0.7P	M4 x 0.7P	M5 x 0.8P	M5x0.8P	M6x1P	M6x1P	M8x1.25P	M8x1.25P	M10x1.5P	M10x1.5P	M12x1.75P
C3 <sup>3</sup>	≤11 / ≤12 <sup>4</sup>	≤11 / ≤12 <sup>4</sup>	≤14 / ≤16 <sup>4</sup>	≤14 / ≤15.875 / ≤16	≤19 / ≤24 <sup>4</sup>	≤19 / ≤24 <sup>4</sup>	≤32	≤32	≤38	≤38	≤48
C4 <sup>3</sup>	25	25	34	34	40	40	50	50	60	60	85
C5 <sup>3</sup>	30	30	50	50	80	80	110	110	130	130	180
C6 <sup>3</sup>	3.5	3.5	8	8	4	4	5	5	6	6	6
C7 <sup>3</sup>	42	42	60	60	90	90	115	115	142	142	190
C8 <sup>3</sup>	29.5	29.5	19	19	17	17	19.5	19.5	22.5	22.5	29
C9 <sup>3</sup>	90.5	99.5	111.5	126.5	152.5	165	191.5	205	235.5	254.5	323.5
C10 <sup>3</sup>	8.75	8.75	13.5	13.5	10.75	10.75	13	13	15	15	20.75
B1 <sub>h9</sub>	5	5		6		10		12		16	20
H1	15	18		24.5		35		43		59	79.5
X	-	W16x0.8x30x18x6m		W22x1.25x30x16x6m		W32x1.25x30x24x6m		W40x2x30x18x6m		W55x2x30x26x6m	W70x2x30x34x6m
DIN5480	-										

3. C1~C10 are motor specific dimensions (metric std shown). Refer to [www.apexdyna.com](http://www.apexdyna.com) and Design Tool to view your specific motor mounting system.  
 4. ABR042M1 offers C3 ≤ 12 option; ABR060/A M1 offers C3 ≤ 12/16 option; ABR090/A M1 offers C3 ≤ 16/24 option; ABR090 M2 offers C3 ≤ 15.875. ABR115M1 offers C3 ≤ 24 option.

# Selection of the Optimum Gearbox

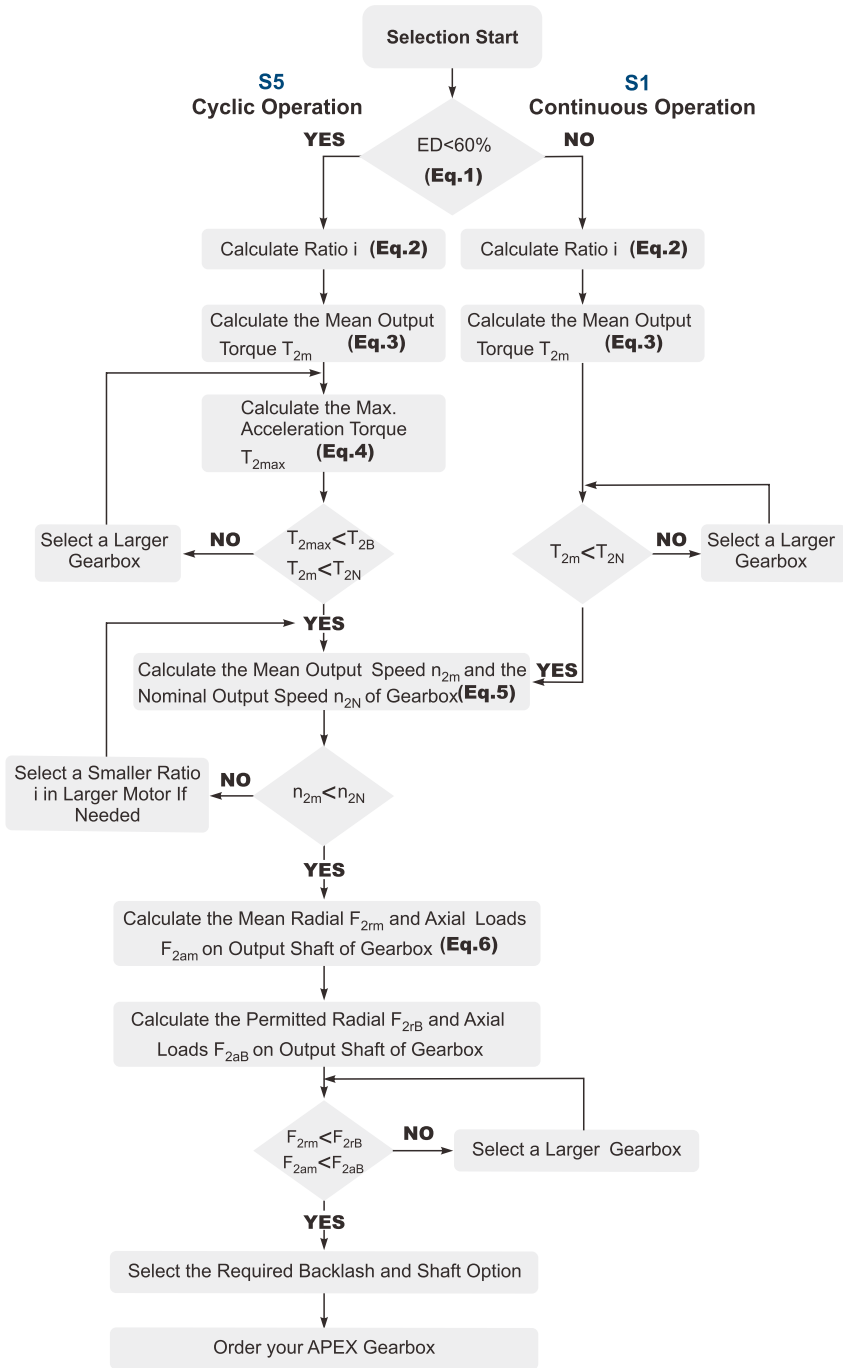

**Recommended (for S5 Cycle Operation)**

The general design is given for

$$\frac{J_L}{i^2} \leq 4 \times J_m$$

The optimal design is given for

$$\frac{J_L}{i^2} \cong J_m$$

$J_L$  Load Inertia

$J_m$  Motor Inertia

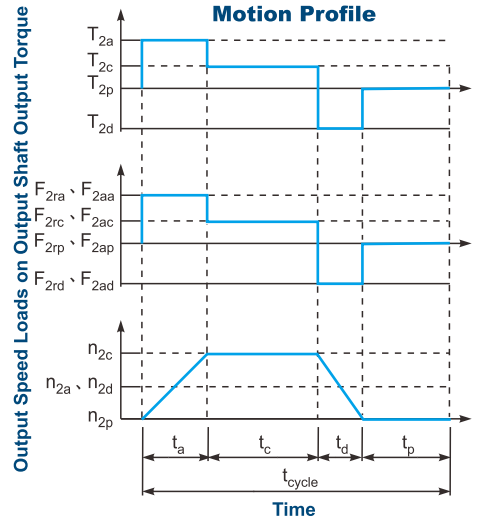

$$1. ED = \frac{t_a + t_c + t_d}{t_{cycle}} \times 100\% .$$

Index : a. Acceleration, c. Constant, d. Deceleration, p. Pause **(Eq.1)**

$$2. i \cong \frac{n_m}{n_{work}}$$

$n_m$  Output Speed of the Motor  
 $n_{work}$  Working Speed **(Eq.2)**

$$3. T_{2m} = \sqrt[3]{\frac{n_{2a} \times t_a \times T_{2a}^3 + n_{2c} \times t_c \times T_{2c}^3 + n_{2d} \times t_d \times T_{2d}^3}{n_{2a} \times t_a + n_{2c} \times t_c + n_{2d} \times t_d}}$$

**(Eq.3)**

$$4. T_{2max} = T_{mB} \times i \times K_s \times \eta$$

where  $K_s$  is

$K_s$	No. of Cycles / hr
1.0	0 ~ 1,000
1.1	1,000 ~ 1,500
1.3	1,500 ~ 2,000
1.6	2,000 ~ 3,000
1.8	3,000 ~ 5,000

$T_{mB}$  Max. Output Torque of the Motor  
 $\eta$  Efficiency of the Gearbox **(Eq.4)**

$$5. n_{2a} = n_{2d} = \frac{1}{2} \times n_{2c}$$

$$n_{2m} = \frac{n_{2a} \times t_a + n_{2c} \times t_c + n_{2d} \times t_d}{t_a + t_c + t_d}$$

$$n_{2N} = \frac{n_{1N}}{i}$$

**(Eq.5)**

$$6. F_{2m} = \sqrt[3]{\frac{n_{2a} \times t_a \times F_{2ra}^3 + n_{2c} \times t_c \times F_{2rc}^3 + n_{2d} \times t_d \times F_{2rd}^3}{n_{2a} \times t_a + n_{2c} \times t_c + n_{2d} \times t_d}}$$

$$F_{2am} = \sqrt[3]{\frac{n_{2a} \times t_a \times F_{2aa}^3 + n_{2c} \times t_c \times F_{2ac}^3 + n_{2d} \times t_d \times F_{2ad}^3}{n_{2a} \times t_a + n_{2c} \times t_c + n_{2d} \times t_d}}$$

**(Eq.6)**

**Liability Disclaimer:**

APEX DYNAMICS, INC. endeavors to ensure the accuracy and reliability of the data in catalog. APEX accepts no liability, whether in any form, for any loss or damage arising from any inaccuracy or omissions of this catalog.

# Permitted Radial and Axial Loads

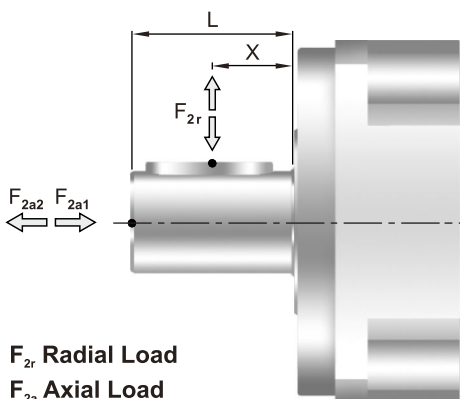

The permitted radial and axial loads on output shaft of the gearbox depend on the design of the gearbox supporting bearings. APEX use the extension straddle oversized ball bearing design. It can take heavy load from both axes.

$F_{2r}$  Radial Load  
 $F_{2a}$  Axial Load

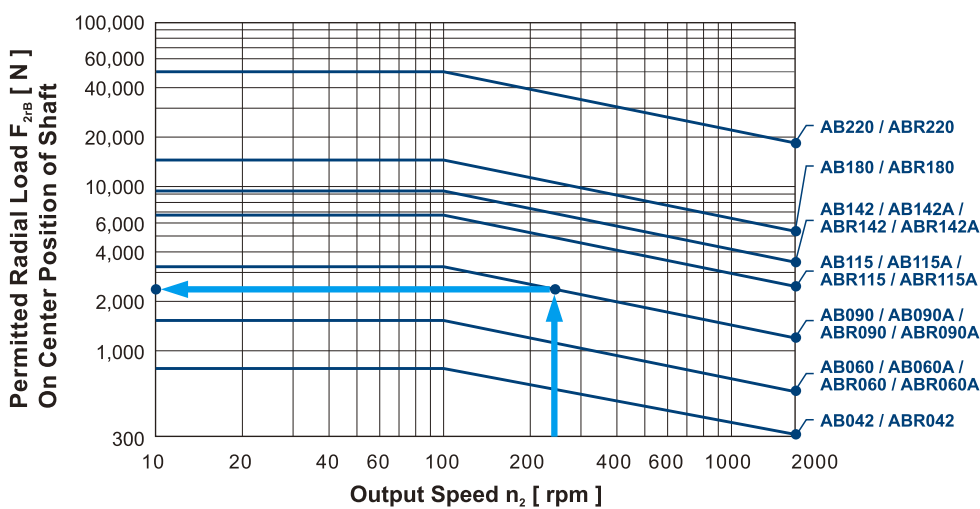

If radial force  $F_{2r}$  exert on the center of the output shaft  $X=1/2 \times L$ . The permitted radial load is given on left diagram.

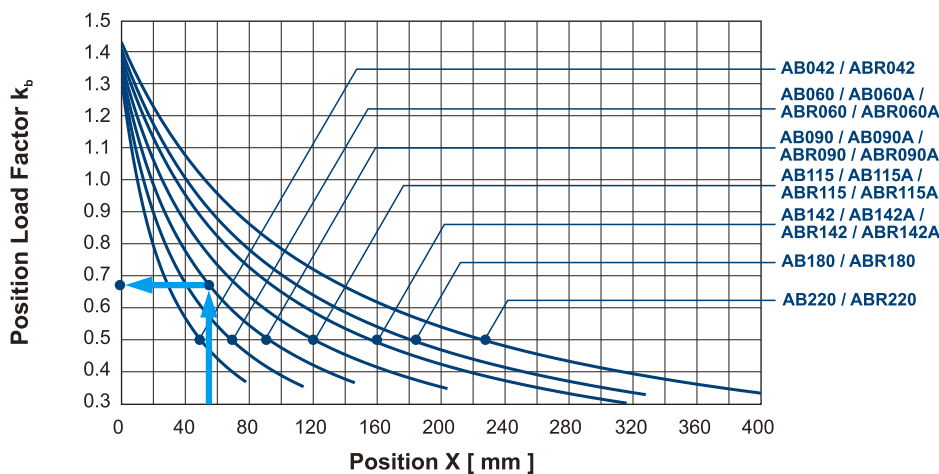

If radial force  $F_{2r}$  not exert on the center of the output shaft  $X < 1/2 \times L$  or  $X > 1/2 \times L$ . The permitted radial and axial load can be calculated by the position load factor  $k_b$  on the left diagram.