

## *F-SERIES*

### *Asynchronous brake motors*

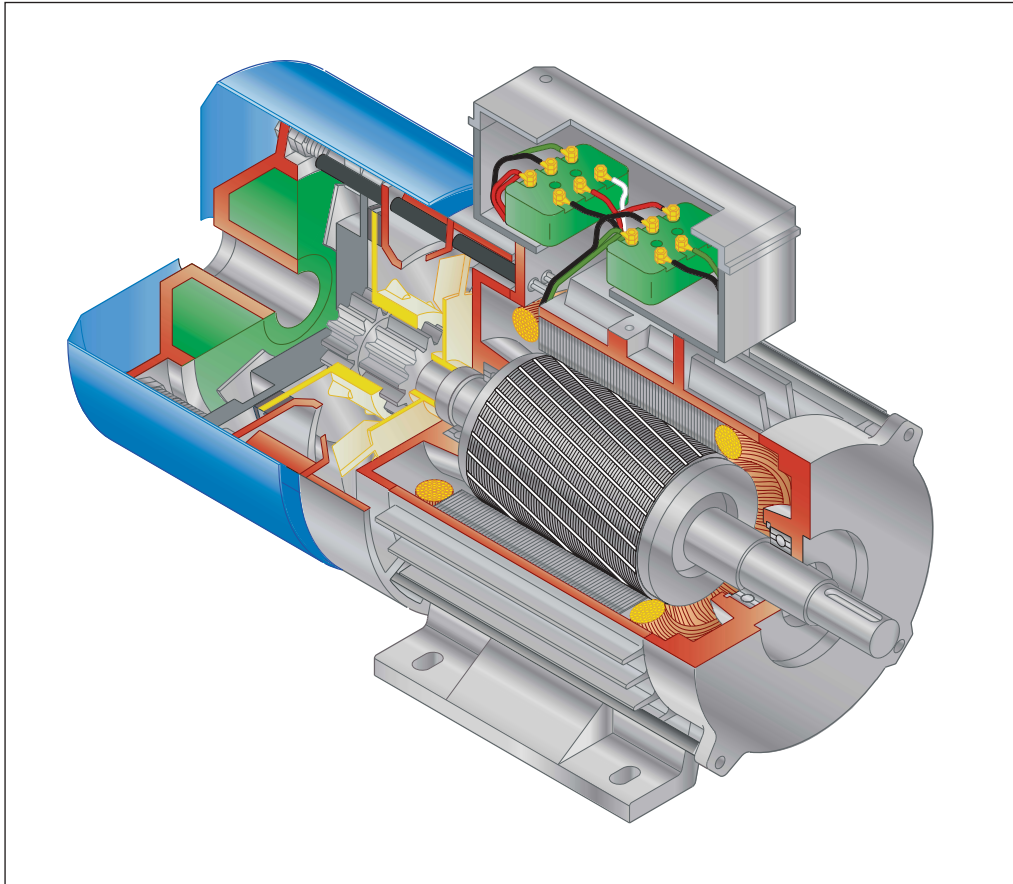

Coel motors are completely enclosed and externally ventilated. The brake groups as all motor parts are made by Coel to make each motor the sum of details, meticulously united. The brake group is supplied on series with "3ph. AC" electromagnet but DC version is also available on request. The F series motors can be controlled by inverter but in this case the separated brake supply will be necessary.

Cases of motors are in die cast pressed aluminium from 56 to 160 frame and in cast iron for frames 180 and 200. The shafts are in high resistance 38NCD4 steel settled with an hexagon on the back side for the manual rotation of the shaft.

The brake can be manually released with a special screw supplied with the motor. The surfaces of attrition are in cast iron and the one to the motor side is auto ventilated. The F series motor will ensure very high braking precision and braking constancy.

The double terminal box is provided of two additional cable presses on the same side. The F series motor is able to bear very hard work cycles thanks to its sturdiness.

#### *Features*

- Disk brake without axial sliding of the shaft.
- Adjustment of braking torque within very ample range of values.
- Brake operation within very low noise and amperage levels.
- F motors are fitted with the three-phase electromagnet as standard. The electromagnet single-phase can be fitted on request. The latter stands out for its speed of intervention and the extremely low noise emitted thanks to the exclusive COEL system it is made with.
- F-FL motors are provided, as standard, with manual release of the brake, 0.3mm thickness gauge for the adjustment of the magnetic gap of the brake group and hexagon-shaped nut on the shaft's rear end, for its manual rotation.

## F-SERIES

### Asynchronous brake motors

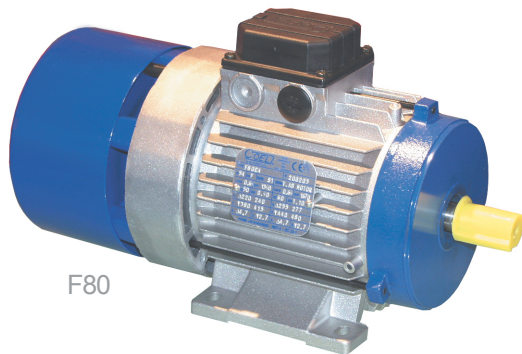

F80

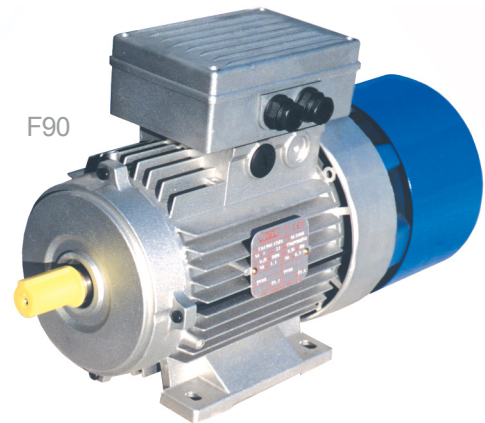

F90

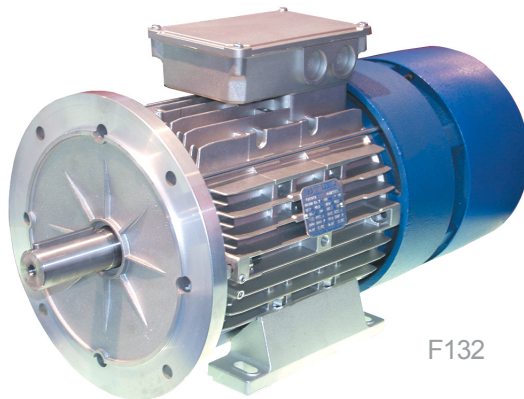

F132

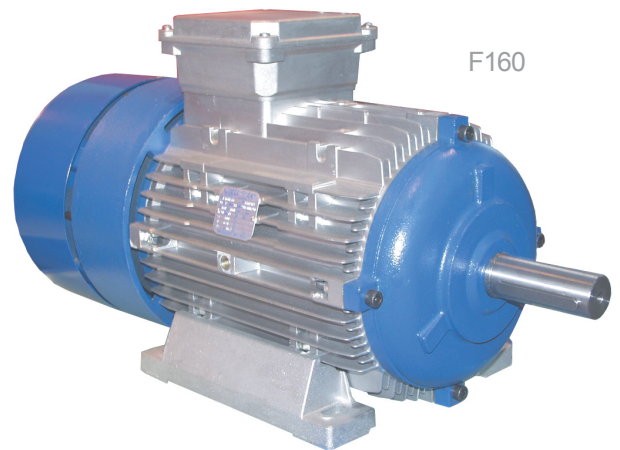

F160

### Possible product configurations

- Motors with feet (B3)
- Motors with feet and flange
- Motors with flange B5 or B14
- Motors with B5 reduced flange from frame 71 to 160
- Motors with B14 reduced flange from frame 71 to 100
- Reduced shafts
- Double shafts
- Special shafts
- Motors B3 with terminal box on the side (up side on series)
- Custom executions
- Special windings
- Motors with forced ventilation
- Separated brake supply
- Separated brake supply
- DC brake
- FL series with progressive start up
- Insulation in H class
- IP protection higher than IP54
- Special "P" rotor for start up torque increasing
- Special painting (also for sea ambient)
- Thermal protections
- Condense resistors
- R or S level equilibration of the rotor
- Application of encoder

For other special requests, please contact COEL

## F Spare parts

Please indicate number of item to order

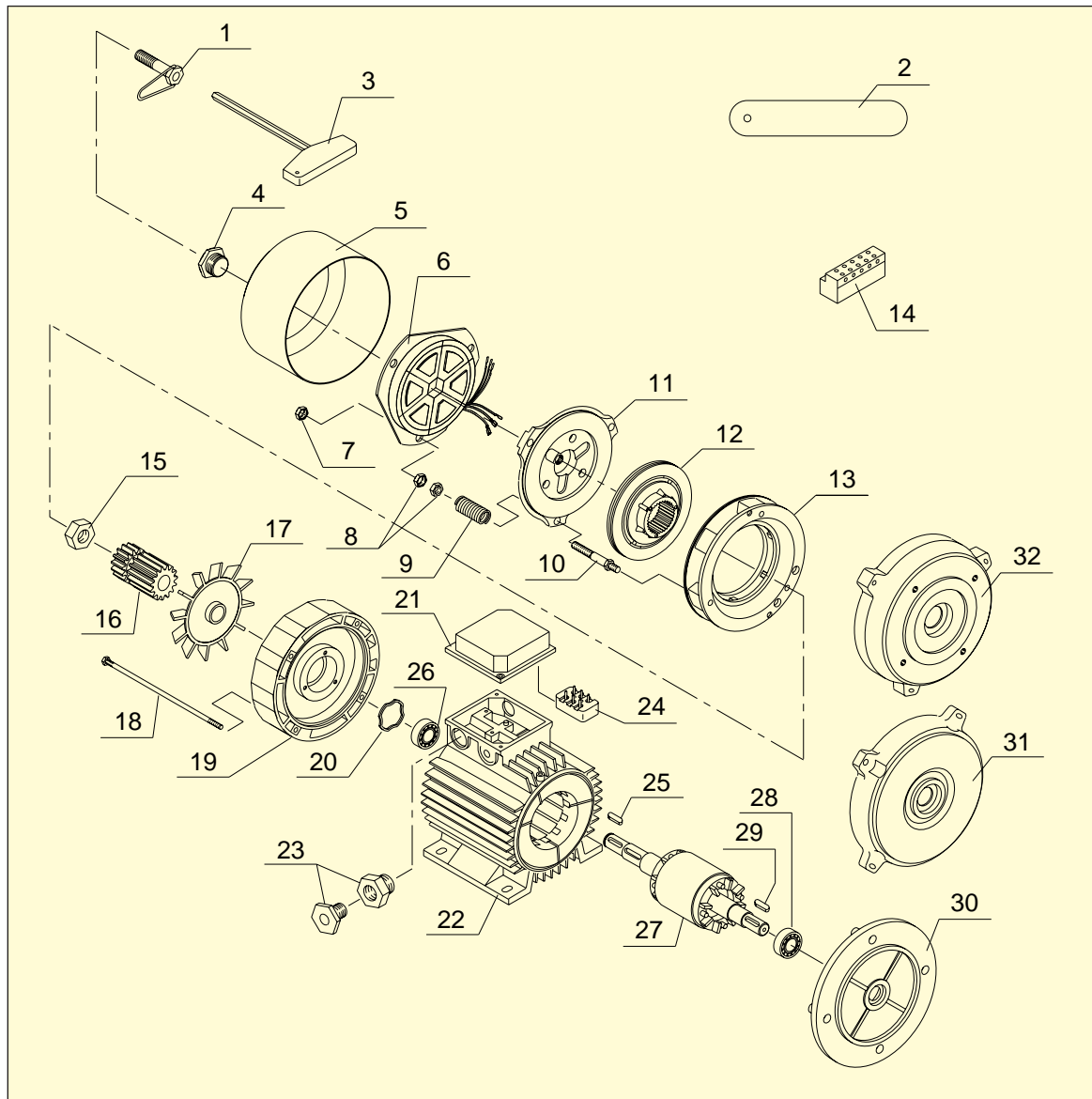

1	Manual release screw	18	Drawrods with nuts
2	0,3 mm thickness gauge	19	Brake side shield
3	Key for manual rotation	20	Compensation ring
4	Cap locking screw	21	Single or double terminal board box
5	Brake protection cover	22	Motor frame
6	Electromagnet (AC or DC)	23	Cable press
7	Magnet locking nut	24	Terminal board
8	Adjustment nuts	25	Brake side key
9	Brake springs	26	Brake side bearing
10	Guide stud bolt	27	Rotor shaft group
11	Mobile anchor	28	Control side bearing
12	Brake disk	29	Control side key
13	Conveyor with friction track	30	B5 flange
14	Rectifier (half or complete wave)	31	B3 shield
15	Seeger or gear locking ring	32	B14 flange
16	Brake Gear		
17	Fan		

# Connections

**SEPARATE POWER SUPPLY  
three-phase motor and brake**

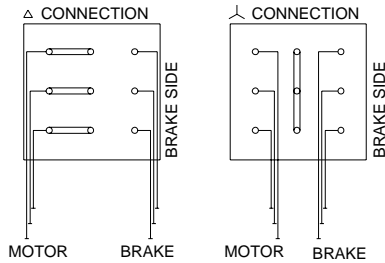

**SEPARATE POWER SUPPLY  
three-phase motor and brake**

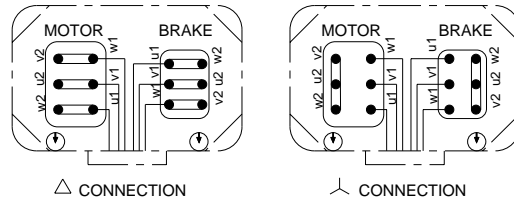

**TWO SPEEDS  
SINGLE WINDING**

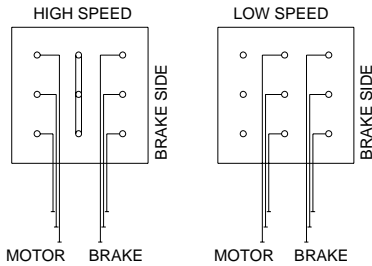

**SEPARATE POWER SUPPLY D.C. BRAKE**

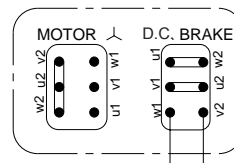

**TWO SPEEDS  
DUAL WINDING**

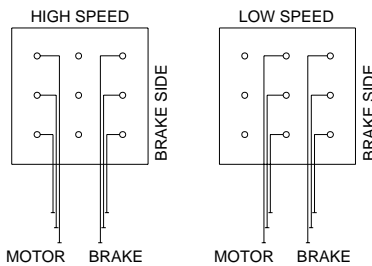

**TWO SPEEDS  
SINGLE WINDING**

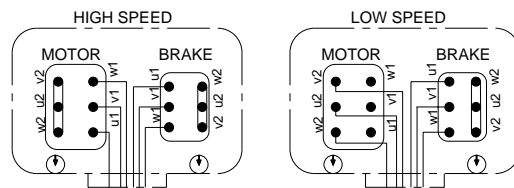

**SINGLE SPEED**

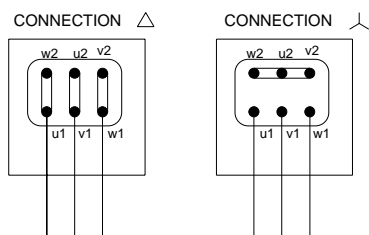

**TWO SPEEDS  
DUAL WINDING**

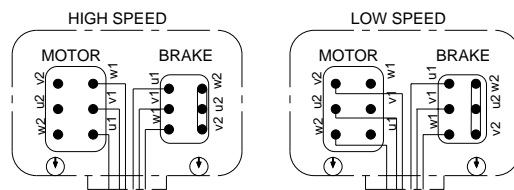

The three-phase brake can be connected both at  $\Delta$  and at  $Y$   
Always connect the ground wire

## F series braking group

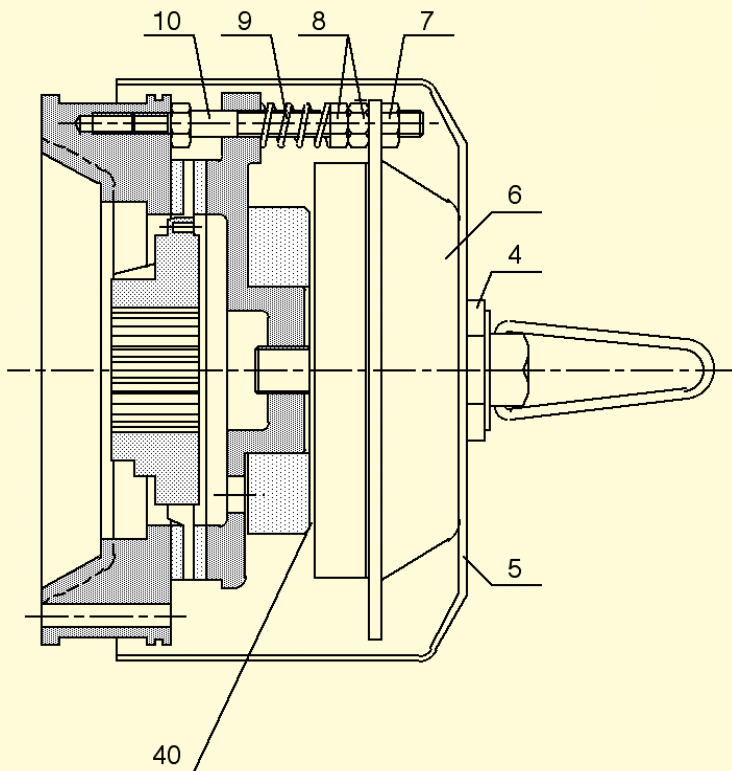

### Magnetic gap adjustment

Magnetic gap 40 (i.e. the distance between the two magnetic cores of the electromagnet and of the mobile anchor) must be  $\frac{3}{10}$ th of a millimeter. Magnetic gap should be periodically checked since, as the brake disk gaskets wear out, it tends to increase.

In order to re-adjust magnetic gap to the required value turn the couples of nuts (7-8) fixing the electromagnet, to advance the latter toward the mobile anchor. Once magnetic gap has been adjusted check that nuts have been correctly tightened.

### Braking torque adjustment

Braking torque is proportional to compression of springs 9; such compression can be varied by acting on nuts 8 (loosen to decrease, tighten to increase).

Compression of the three springs must be uniform.

### Replacing the electromagnet

Loosen screw 4, remove cap 5, detach the 6 terminals of the magnet, loosen the three nuts 7 and slip electromagnet 6 off stud bolts 10.

Slip the new electromagnet on to the stud bolts, making sure that when reinserting the terminals that colours do not match.

Tighten nuts 7-8 and check that the new electromagnet operates regularly.

### Replacing the brake disk

Loosen nut 4, remove cap 6 and loosen the three nuts 7 without detaching the terminals. Remove nuts 8 and spring 9. Mount the new brake disk.

*Three phase 2 poles - 3000 r.p.m.*

Type	kW	r.p.m.	Cos. $\phi$	I n V.400	Ma/Mn	I.A/I.N	Inertia moment Jx Kg $m^2$	Braking Torque MAX Nm.	Starts C/h	A.V.400 Brake A.C. (m A)	A. V.230AC brake D.C. (m A)	Weight KG.
F71A2	0,37	2765	0,79	1,10	2,5	3,9	0,00071	15	6000	110	90	9,5
F71B2	0,55	2780	0,79	1,50	2,5	3,9	0,00082	15	5000	110	90	10,5
F71C2*	0,75	2780	0,76	2,10	2,3	4,3	0,00098	15	4000	110	90	11,5
F80A2	0,75	2780	0,77	2,00	3,0	4,8	0,00146	20	6000	180	180	14,4
F80B2	1,10	2780	0,82	2,90	3,0	4,9	0,00129	20	5300	180	180	15,5
F90SA2	1,50	2780	0,86	3,50	2,5	6,8	0,00189	40	4000	250	250	20
F90SB2	1,84	2780	0,86	4,30	2,5	6,8	0,00200	40	3500	250	250	21,5
F90LA2	2,20	2800	0,88	4,70	2,5	6,8	0,00232	40	3000	250	250	23
F100LA2	3,00	2800	0,88	6,50	2,9	8,0	0,00572	48	1200	250	250	32
F112MB2	4,00	2820	0,87	8,20	2,4	7,4	0,00720	80	900	500	550	45
F132SA2	5,50	2880	0,85	11,0	2,3	7,5	0,03100	150	500	800	600	78,5
F132SB2	7,50	2880	0,85	15,0	2,3	7,5	0,03320	150	500	800	600	84,5
F132MA2*	9,20	2870	0,88	18,0	2,3	7,5	0,03980	150	500	800	600	87
F132MB2*	11,00	2870	0,89	21,0	2,3	7,5	0,04620	150	500	800	600	94
F160MA2	11,00	2890	0,88	20,8	3,0	9,0	0,06020	175	300	800	600	148
F160MB2	15,00	2900	0,87	29,0	3,0	8,0	0,06260	175	300	800	600	150
F160LA2	18,50	2900	0,90	33,0	3,0	8,0	0,08960	175	290	800	600	167
F180LA2	22,00	2940	0,90	39,0	2,0	7,5	0,16800	300	190	800	600	210
F200LA2	30,00	2950	0,90	53,0	2,0	7,5	0,20000	300	190	800	600	230
F200LB2	37,00	2950	0,89	65,5	2,0	7,5	0,21000	300	190	800	600	250

\*non unified powers

- 1) Motors from frame 71 to 132 are supplied with voltage at 220/380/50 240/415/50 255/440/60 277/480/60
- 2) Motors frame 160, 180, 200, are supplied as series with motor at V.400/690/50 and electromagnet at V.230/400/50
- 3) The braking torque values can be reduced of about 10% if the electromagnet is DC.



*Three phase 4 poles - 1500 r.p.m.*

Type	kW	r.p.m.	Cos. $\phi$	I n V.400	Ma/Mn	I.A/I.N	Inertia moment Jx Kgm <sup>2</sup>	Braking Torque MAX Nm.	Starts C/h	A.V.400 Brake A.C. (m A)	A. V.230AC brake D.C. (m A)	Weight KG.
F71A4	0,25	1400	0,65	0,9	2,70	3,9	0,00071	15	19500	110	90	9,5
F71B4	0,37	1390	0,70	1,2	2,70	4,1	0,00082	15	18000	110	90	10,5
F71C4*	0,55	1360	0,72	1,7	2,30	3,1	0,00098	15	15000	110	90	11,5
F80A4	0,55	1390	0,68	1,7	2,30	4,0	0,00146	20	10000	180	180	14
F80B4	0,75	1400	0,70	2,2	2,60	4,2	0,00173	20	10000	180	180	15,5
F80C4*	0,90	1390	0,69	2,7	2,50	4,3	0,00185	20	9000	180	180	16,5
F90SA4	1,10	1400	0,77	2,7	2,30	4,6	0,00284	40	10000	250	250	21
F90LA4	1,50	1400	0,75	3,7	3,00	4,9	0,00305	40	10000	250	250	23
F90LB4*	1,85	1400	0,77	4,3	3,00	4,6	0,00388	40	9000	250	250	24
F90LC4*	2,20	1400	0,78	5,4	2,90	4,3	0,00430	40	8000	250	250	26
F100LA4	2,20	1410	0,78	5,0	2,70	5,5	0,00572	48	7500	250	250	32
F100LB4	3,00	1410	0,82	6,4	2,70	5,0	0,00612	48	7000	250	250	36
F100LC4*	3,30	1410	0,80	7,5	2,60	4,7	0,00750	48	7000	250	250	41
F112MB4	4,00	1430	0,85	8,2	2,70	5,8	0,01180	80	3300	500	550	47
F132SB4	5,50	1440	0,81	11,3	2,60	5,8	0,03320	150	1200	800	600	84,5
F132MA4	7,50	1430	0,85	14,6	2,30	5,8	0,03900	150	1000	800	600	94,5
F132MB4*	9,00	1430	0,84	17,9	2,30	5,8	0,04620	150	900	800	600	100
F160MB4	11,00	1460	0,80	22,0	2,80	5,9	0,06260	175	600	800	600	148
F160LA4	15,00	1460	0,82	29,0	2,30	5,9	0,08960	175	600	800	600	167
F160LB4*	18,50	1450	0,83	37,0	2,20	5,8	0,09480	175	600	800	600	190
F180LA4	18,50	1470	0,85	34,5	2,20	7,5	0,1670	300	540	800	600	210
F180LB4	22,0	1470	0,86	39,8	2,20	7,5	0,1990	300	530	800	600	230
F200LB4	30,0	1470	0,86	53,1	2,20	7,2	0,1213	300	300	800	600	250

\*non unified powers

- 1) Motors from frame 71 to 132 are supplied with voltage at 220/380/50 240/415/50 255/440/60 277/480/60
- 2) Motors frame 160, 180, 200, are supplied as series with motor at V.400/690/50 and electromagnet at V.230/400/50
- 3) The braking torque values can be reduced of about 10% if the electromagnet is DC.

*Three phase 6 poles - 1000 r.p.m.*

Type	kW	r.p.m.	Cos. $\varphi$	I n V.400	Ma/Mn	I.A/I.N	Inertia moment Jx Kgm <sup>2</sup>	Braking Torque MAX Nm.	Starts C/h	A.V.400 Brake A.C. (m A)	A. V.230AC brake D.C. (m A)	Weight KG.
F71A6	0,18	900	0,69	0,8	1,9	2,5	0,00091	15	22000	110	90	10,5
F71B6	0,25	910	0,69	1,0	2,0	2,5	0,00123	15	22000	110	90	11
F71C6*	0,30	900	0,68	1,2	1,9	2,6	0,00141	15	19000	110	90	11,5
F80A6	0,37	900	0,66	1,3	2,6	3,5	0,00223	20	18000	180	180	14,5
F80B6	0,55	900	0,68	1,8	2,6	3,5	0,00280	20	18000	180	180	16
F90SA6	0,75	910	0,68	2,3	2,2	3,3	0,00356	40	18000	250	250	20
F90LA6	1,10	910	0,68	3,3	2,3	3,7	0,00472	40	14000	250	250	23
F100LA6	1,50	930	0,71	3,9	2,4	4,3	0,00874	48	9000	250	250	33
F100LB6*	1,85	920	0,68	5,0	2,6	4,3	0,00996	48	8500	250	250	36
F112MB6	2,20	940	0,78	5,2	2,3	5,3	0,01680	80	4500	500	550	47
F132SB6	3,00	960	0,76	7,0	2,1	5,6	0,03100	150	3000	800	600	84,5
F132MA6	4,00	960	0,76	9,1	2,7	5,6	0,04250	150	3000	800	600	94,5
F132MB6	5,50	960	0,78	12	2,1	5,5	0,05150	150	2800	800	600	100
F160MB6	7,50	950	0,79	18	2,1	5,6	0,09700	175	900	800	600	148
F160LA6*	9,50	950	0,80	22	2,0	5,5	0,1230	175	900	800	600	170
F160LB6	11,00	960	0,80	26	2,0	5,5	0,1433	175	900	800	600	175
F180LB6	15,00	970	0,81	30	2,1	7,0	0,2180	300	580	800	600	210
F200LA6	18,50	970	0,81	37	2,1	7,0	0,2200	300	330	800	600	230
F200LB6	22,00	970	0,83	43	2,1	7,0	0,2550	300	330	800	600	250

\*non unified powers

- 1) Motors from frame 71 to 132 are supplied with voltage at 220/380/50 240/415/50 255/440/60 277/480/60
- 2) Motors frame 160, 180, 200, are supplied as series with motor at V.400/690/50 and electromagnet at V.230/400/50
- 3) The braking torque values can be reduced of about 10% if the electromagnet is DC.



*Three phase 8 poles - 750 r.p.m.*

Type	kW	r.p.m.	Cos. $\varphi$	I n V.400	Ma/Mn	I.A/I.N	Inertia moment Jx Kgm <sup>2</sup>	Braking Torque MAX Nm.	Starts C/h	A.V.400 Brake A.C. (m A)	A. V.230AC brake D.C. (m A)	Weight KG.
F71B8	0,12	660	0,55	0,9	2,0	2,7	0,00123	15	22000	110	90	10,5
F80A8	0,18	670	0,59	1,0	1,8	3,2	0,00223	20	20000	180	190	15
F80B8	0,25	670	0,64	1,3	1,7	3,0	0,00280	20	19000	180	190	15,5
F90SA8	0,37	690	0,56	1,6	2,2	2,8	0,00356	40	20000	250	250	20
F90LA8	0,55	690	0,57	2,3	2,2	2,9	0,00472	40	18000	250	250	22
F100LA8	0,75	700	0,59	2,8	2,3	3,2	0,00874	48	12000	250	250	33
F100LB8	1,10	700	0,60	3,6	2,1	3,5	0,00996	48	10000	250	250	35
F112MB8	1,50	710	0,65	4,5	1,9	4,0	0,01680	80	5000	500	550	46
F132SB8	2,20	715	0,72	5,3	1,7	4,8	0,03100	150	3200	800	600	85
F132MA8	3,00	720	0,69	8,5	1,8	4,8	0,04250	150	3000	800	600	93,5
F160MA8	4,00	710	0,71	11	2,0	5,0	0,09500	175	1200	800	600	135
F160MB8	5,50	710	0,73	13	2,0	5,0	0,12300	175	1100	800	600	150
F160LA8	7,50	710	0,71	18	2,2	5,0	0,11800	175	1000	800	600	170
F180LB8	11,0	730	0,75	24	2,0	6,0	0,22000	300	750	800	600	190
F200LA8	15,0	730	0,76	33	1,8	6,5	0,25200	300	450	800	600	250

- 1) Motors from frame 71 to 132 are supplied with voltage at 220/380/50 240/415/50 255/440/60 277/480/60
- 2) Motors frame 160, 180, 200, are supplied as series with motor at V.400/690/50 and electromagnet at V.230/400/50
- 3) The braking torque values can be reduced of about 10% if the electromagnet is DC.

*Three phase 2/4 poles - 3000/1500 r.p.m.*

Type	kW	r.p.m.	Cos. $\varphi$	I n V.400	Ma/Mn	I.A/I.N	Inertia moment Jx Kgm <sup>2</sup>	Braking Torque MAX Nm.	Starts C/h	A.V.400 Brake A.C. (m A)	A. V.230AC brake D.C. (m A)	Weight KG.
FD71A2/4	0,26 0,18	2800 1380	0,73 0,68	0,8 0,7	2,5 2,4	4,6 3,9	0,00082	15	7000 12000	110	90	10,3
FD71B2/4	0,37 0,26	2800 1390	0,85 0,78	0,90 0,90	2,4 2,3	4,7 3,0	0,00098	15	6000 10000	110	90	11
FD71C2/4	0,45 0,30	2800 1390	0,76 0,70	1,4 1,1	2,6 2,3	4,7 3,9	0,00146	15	5500 9000	110	90	11,5
FD80A2/4	0,65 0,45	2800 1400	0,77 0,72	1,8 1,4	2,3 2,2	5,0 4,8	0,00173	20	3000 10000	180	190	15
FD80B2/4	0,9 0,6	2800 1415	0,78 0,73	2,3 1,8	2,4 2,3	5,1 5,0	0,00290	20	2500 8000	180	190	15,5
FD90SB2/4	1,3 0,9	2800 1420	0,85 0,73	3,3 2,4	2,3 2,3	4,7 4,5	0,00305	40	2000 7500	250	250	20
FD90LA2/4	1,8 1,2	2800 1420	0,81 0,71	4,5 3,2	2,7 2,9	4,9 4,8	0,00388	40	2000 7000	250	250	22
FD90LB2/4	2,2 1,5	2800 1400	0,80 0,74	5,5 3,9	2,7 3,0	4,9 4,6	0,00572	40	1800 7000	250	250	24
FD100LA2/4	2,5 1,9	2860 1420	0,85 0,82	5,2 3,9	2,6 2,4	6,2 5,4	0,00612	48	1000 5500	250	250	36,3
FD100LB2/4	3,3 2,4	2870 1420	0,85 0,77	7,0 5,3	2,8 2,5	7,0 6,3	0,01180	48	1000 5000	250	250	39,7
FD112MB2/4	4,5 3,3	2880 1410	0,87 0,86	9,3 6,9	2,4 2,3	7,0 6,3	0,03120	80	500 2000	500	550	48
FD132SB2/4	5,1 4,5	2810 1400	0,91 0,81	11 10	2,7 2,5	5,1 5,8	0,04000	150	450 1500	800	600	84,5
FD132MA2/4	6,0 5,0	2810 1400	0,93 0,80	12,5 12,0	3,0 2,8	5,2 5,8	0,05900	150	400 1000	800	600	94,5
FD160MA2/4	9,50 8,0	2800 1410	0,86 0,85	17 15	2,8 2,3	8,5 5,8	0,06260	175	200 400	800	600	142
FD160MB2/4	11 9,0	2830 1410	0,86 0,86	24 20	2,4 2,3	8,5 5,6	0,08960	175	200 350	800	600	150
FD160LA2/4	13 11	2830 1450	0,86 0,84	27 22	2,5 2,2	8,8 5,5	0,16700	175	150 300	800	600	170
FD180LA2/4	17 14	2830 1420	0,90 0,87	36 29	2,2 2,0	6,0 6,0	0,19900	300	100 300	800	600	210
FD180LB2/4	20 17	2830 1420	0,90 0,87	41 34	2,2 2,0	6,5 6,0	0,12130	300	100 300	800	600	230
FD200LB2/4	28 24	2900 1450	0,90 0,87	58 50	2,2 2,0	6,5 3,0		300	70 200	800	600	250

3) The braking torque values can be reduced of about 10% if the electromagnet is DC.

*Three phase 2/6 poles - 3000/1000 r.p.m.*

Type	kW	r.p.m.	Cos. $\varphi$	I n V.400	Ma/Mn	I.A/I.N	Inertia moment Jx Kgm <sup>2</sup>	Braking Torque MAX Nm.	Starts C/h	A.V.400 Brake A.C. (m A)	A. V.230AC brake D.C. (m A)	Weight KG.
FDA71B2/6	0,25 0,08	2850 930	0,75 0,65	0,95 0,75	2,4 2	4,5 2,4	0,00082	15	3800 12000	110	90	10,5
FDA71C2/6	0,35 0,10	2860 950	0,73 0,66	1,1 1,0	2,3 2,1	5,0 3,4	0,00098	15	3600 11000	110	90	11,2
FDA80A2/6	0,37 0,12	2860 930	0,66 0,58	1,4 0,9	2,5 2,1	4,9 3,3	0,00146	20	2000 10000	180	190	14
FDA80B2/6	0,55 0,18	2860 940	0,67 0,56	1,9 1,2	2,3 2,1	5,2 3,3	0,00173	20	2000 10000	180	190	15,5
FDA90SA2/6	0,90 0,30	2870 940	0,84 0,64	2,1 1,2	2,6 2,2	6,5 2,5	0,00284	40	1900 9000	250	250	20
FDA90LA2/6	1,20 0,40	2870 950	0,81 0,66	2,9 1,7	2,3 2,0	6,3 3,5	0,00305	40	1800 8000	250	250	22
FDA100LB2/6	2,20 0,80	2800 910	0,85 0,64	4,9 2,6	2,7 2,2	6,7 3,5	0,00612	48	900 6000	250	250	39
FDA112MB2/6	3,00 1,00	2880 930	0,85 0,62	6,60 3,50	2,9 2,3	7,1 4,0	0,01180	80	500 4000	500	550	48
FDA132SB2/6	4,00 1,50	2860 920	0,84 0,58	9,5 4,3	2,6 2,1	8,6 5,1	0,03120	150	350 1600	800	600	85
FDA132MB2/6	6,45 2,20	2860 910	0,82 0,60	15,0 7,5	2,7 2,1	8,3 5,5	0,04620	150	350 1600	800	600	102
FDA160LA2/6	11,00 3,40	2860 960	0,84 0,58	20,0 12,0	2,7 2,2	7,1 4,2	0,08960	175	250 900	800	600	170
FDA180LB2/6	16,00 6,50	2800 950	0,79 0,67	39 22	2,3 3,0	7,0 5,3	0,11560	300	90 230	800	600	253

3) The braking torque values can be reduced of about 10% if the electromagnet is DC.

*Three phase 2/8 poles - 3000/750 r.p.m.*

Type	kW	r.p.m.	Cos. $\varphi$	I n V.400	Ma/Mn	I.A/I.N	Inertia moment Jx Kgm <sup>2</sup>	Braking Torque MAX Nm.	Starts C/h	A.V.400 Brake A.C. (m A)	A. V.230AC brake D.C. (m A)	Weight KG.
FDA71B2/8	0,25 0,06	2800 690	0,71 0,60	0,95 0,6	2,4 1,9	4,5 2,3	0,00082	15	3600 15000	110	90	10,5
FDA71C2/8	0,35 0,07	2800 690	0,71 0,60	1,3 0,7	2,3 1,9	5,0 2,2	0,00098	15	3600 15000	110	90	11,5
FDA80A2/8	0,37 0,09	2800 690	0,66 0,53	1,4 0,75	2,5 1,9	4,4 2,3	0,00146	20	2000 12000	180	190	14
FDA80B2/8	0,55 0,12	2800 690	0,69 0,53	1,9 0,9	2,3 2	5,2 5,4	0,00173	20	2000 12000	180	190	15,5
FDA90SB2/8	0,75 0,18	2820 700	0,70 0,54	2,1 1,1	2,6 1,9	5,5 2,3	0,00295	40	1900 10000	250	190	20
FDA90LA2/8	1,10 0,30	2820 700	0,75 0,55	2,7 1,5	2,5 1,9	5,6 2,4	0,00305	40	1800 10000	250	250	22
FDA90LB2/8	1,30 0,30	2820 700	0,78 0,58	3,1 1,8	2,4 2	5,8 2,3	0,00388	40	1800 9000	250	250	24
FDA100LA2/8	1,50 0,37	2820 700	0,78 0,56	3,9 2,2	2,6 1,8	5,6 2,8	0,00572	48	1000 7000	250	250	36,3
FDA100LB2/8	2,20 0,50	2840 700	0,87 0,58	4,9 2,8	2,5 1,8	5,1 2,9	0,00612	48	900 3000	250	250	39,7
FDA112MA2/8	2,50 0,60	2840 705	0,74 0,57	5,8 3,2	2,4 1,9	5,5 3,0	0,00950	80	500 2500	500	550	47
FDA112MB2/8	3,00 0,80	2850 705	0,74 0,59	6,7 3,6	2,5 2	6,0 3,0	0,01180	80	500 2500	500	550	48
FDA132SB2/8	4,00 1,10	2860 700	0,74 0,60	10,0 4,0	2,6 1,9	6,5 2,9	0,03120	150	300 1500	800	600	84,5
FDA132MA2/8	5,50 1,50	2870 700	0,75 0,61	12,0 5,6	2,5 2,1	6,6 3,0	0,04000	150	300 1300	800	600	94,5
FDA132MB2/8	6,20 1,80	2860 690	0,82 0,67	13,7 6,8	2,5 2,1	6,6 3,0	0,04620	150	300 1300	800	600	100
FDA160LA2/8	11,00 3,00	2900 720	0,90 0,63	24,0 14,0	2,4 2,2	6,8 3,4	0,08960	175	300 1300	800	600	170

3) The braking torque values can be reduced of about 10% if the electromagnet is DC.

*Three phase 4/6 poles 1500/1000 r.p.m.*

Type	kW	r.p.m.	Cos. $\varphi$	I n V.400	Ma/Mn	I.A/I.N	Inertia moment Jx Kgm <sup>2</sup>	Braking Torque MAX Nm.	Starts C/h	A.V.400 Brake A.C. (m A)	A. V.230AC brake D.C. (m A)	Weight KG.
FDA71A4/6	0,13 0,08	1360 890	0,70 0,64	0,7 0,4	2,3 2,0	4,5 3	0,00091	15	7000 10000	110	90	10,5
FDA71B4/6	0,18 0,11	1370 900	0,72 0,67	0,7 0,5	2,3 2,2	4,5 2,9	0,00123	15	7000 10000	110	90	11,5
FDA80A4/6	0,26 0,18	1390 930	0,75 0,68	1,0 0,9	2,4 2,0	4,8 3	0,00223	20	7000 10000	180	190	14
FDA80B4/6	0,37 0,26	1400 930	0,76 0,69	1,1 1,0	2,5 2,0	4,8 3	0,00280	20	6000 8000	180	190	15,5
FDA90SA4/6	0,55 0,37	1410 945	0,77 0,70	1,8 1,6	2,4 2,1	5,5 3,6	0,00356	40	6000 8000	250	250	20
FDA90LA4/6	0,75 0,55	1410 945	0,79 0,60	2,4 2	2,3 2,2	5,6 3,3	0,00472	40	9500 8000	250	250	22
FDA100LB4/6	1,50 1,10	1420 945	0,79 0,70	3,9 3,2	2,6 2,3	5,6 3,5	0,00996	48	4000 6000	250	250	39,7
FDA112MB4/6	2,00 1,30	1430 950	0,86 0,71	4,5 3,6	2,4 2,0	5,3 4,5	0,01680	80	2000 3000	500	550	48,0
FDA132SB4/6	2,20 1,50	1430 930	0,84 0,71	5,0 3,7	2,3 1,9	6 3,4	0,03100	150	600 1000	800	600	84,5
FDA132MA4/6	3,00 2,20	1430 930	0,84 0,72	6,0 5,2	2,4 2,2	6,0 3,6	0,04250	150	800 1200	800	600	94,5
FDA132MB4/6	3,70 2,60	1440 930	0,84 0,72	8,3 6,2	2,3 2,2	6,1 3,8	0,04950	150	700 1000	800	600	100
FDA160MB4/6	5,50 3,70	1450 930	0,85 0,75	12 8,5	2,2 2,0	7 4	0,10700	175	500 700	800	600	148
FDA160LB4/6	7,50 5,50	1450 930	0,84 0,76	17,5 13,5	2,3 2,0	7 4	0,14350	175	400 700	800	600	180
FDA180LA4/6	11,0 7,5	1450 930	0,88 0,70	22 18,5	2,1 2,0	7 5	0,18600	300	250 400	800	600	200
FDA180LB4/6	13 8,8	1450 930	0,88 0,70	27 22	2,2 2,0	7 5	0,21800	300	230 380	800	600	210
FDA200LB4/6	18,5 12,5	1460 970	0,84 0,76	35 25	2,0 2,0	7 6	0,25500	300	120 180	800	600	250

3) The braking torque values can be reduced of about 10% if the electromagnet is DC.

*Three phase 4/8 poles - 1500/750 r.p.m.*

Type	kW	r.p.m.	Cos. $\varphi$	I n V.400	Ma/Mn	I.A/I.N	Inertia moment Jx Kgm <sup>2</sup>	Braking Torque MAX Nm.	Starts C/h	A.V.400 Brake A.C. (m A)	A. V.230AC brake D.C. (m A)	Weight KG.
FD71A4/8	0,13 0,07	1360 680	0,83 0,62	0,5 0,5	2,0 2,2	3,7 2,5	0,00091	15	12000 20000	110	90	10
FD71B4/8	0,18 0,09	1360 680	0,82 0,63	0,7 0,7	2,2 1,9	3,8 2,6	0,00123	15	10000 20000	110	90	10,5
FD71C4/8	0,22 0,12	1360 670	0,80 0,60	0,8 0,8	2,1 1,9	3,9 2,7	0,00141	15	9000 20000	110	90	12
FD80A4/8	0,26 0,18	1410 6750	0,83 0,60	0,9 0,9	2,2 1,9	5,5 3,0	0,00223	20	7000 14000	180	190	14,5
FD80B4/8	0,37 0,26	1405 675	0,84 0,64	0,9 1,2	2,3 2,0	5,5 2,8	0,00280	20	7000 14000	180	190	15,5
FD90SA4/8	0,75 0,37	1400 700	0,85 0,60	2,1 1,9	1,9 2,2	4,0 3,0	0,00356	40	6500 12000	250	250	20
FD90LB4/8	1,10 0,60	1400 700	0,85 0,58	2,7 3,0	2,0 2,2	4,0 3,0	0,00510	40	6000 10000	250	250	24
FD100LB4/8	1,60 0,90	1440 700	0,85 0,61	3,7 3,5	2,2 2,2	4,6 3,2	0,00996	48	4000 8000	250	250	39,7
FD112MB4/8	2,20 1,20	1440 710	0,89 0,59	4,6 4,8	2,2 3,0	5,6 4,0	0,01680	80	2000 4000	500	550	48
FD132SB4/8	3,00 2,00	1430 715	0,88 0,59	6,1 6,9	2,7 2,5	5,5 3,5	0,03100	150	700 2000	800	600	84,5
FD132MA4/8	4,00 2,60	1445 720	0,87 0,63	8,0 8,5	3,0 2,9	5,6 5,5	0,04250	150	500 1500	800	600	98
FD160MA4/8	5,50 3,70	1430 720	0,86 0,64	11,5 12,5	2,5 2,1	5,8 5,3	0,09500	175	600 1200	800	600	139
FD160MB4/8	6,60 4,50	1430 720	0,88 0,65	14,5 13,8	2,3 2,2	5,9 5,3	0,09700	175	600 1200	800	600	148
FD160LA4/8	9,60 6,00	1430 720	0,86 0,66	21 19	2,6 2,1	6,0 5,1	0,12300	175	550 1100	800	600	170
FD180LA4/8	11 8	1460 730	0,85 0,68	22 22	2,2 2,0	6,0 5,0	0,1860	300	400 700	800	600	190
FD180LB4/8	14 10	1450 720	0,87 0,72	28 25	2,2 2,0	6,0 4,5	0,2180	300	400 680	800	600	230
FD200LB4/8	21 13	1460 730	0,87 0,75	41 30	2,0 2,0	6,3 5,0	0,2550	300	80 240	800	600	250

3) The braking torque values can be reduced of about 10% if the electromagnet is DC.



*Three phase 4/12 poles - 1500/500 r.p.m.*

Type	kW	r.p.m.	Cos. φ	I n V.400	Ma/Mn	I.A/I.N	Inertia moment Jx Kgm <sup>2</sup>	Braking Torque MAX Nm.	Starts C/h	A.V.400 Brake A.C. (m A)	A. V.230AC brake D.C. (m A)	Weight KG.
FDA80A4/12	0,25 0,07	1400 410	0,78 0,63	0,90 0,70	1,9 1,8	4,0 1,7	0,00223	20	6000 16000	180	190	14,5
FDA80B4/12	0,37 0,11	1410 410	0,79 0,64	1,2 0,8	1,9 1,7	4,2 1,6	0,00280	20	6000 16000	180	190	15,5
FDA90LA4/12	0,55 0,18	1400 460	0,76 0,65	1,8 1,3	3,1 1,9	3,4 1,5	0,00472	40	5000 15000	250	250	24
FDA100LA4/12	0,90 0,30	1410 460	0,79 0,65	2,4 2,2	2,2 1,8	5,2 1,9	0,00874	48	4000 14000	250	250	34
FDA100LB4/12	1,10 0,37	1410 460	0,79 0,66	2,8 2,7	2,4 1,8	4,9 1,7	0,00996	48	4000 14000	250	250	39,7
FDA112MB4/12	1,50 0,45	1430 460	0,79 0,66	3,7 2,8	2,5 2,3	5,5 2,2	0,01680	80	2000 10000	500	550	47,5
FDA132SA4/12	2,20 0,75	1430 463	0,79 0,68	4,6 3,2	2,4 2,2	6,6 2,5	0,03100	150	900 3000	800	750	82
FDA132MA4/12	3,00 1,00	1430 465	0,79 0,68	6,5 4,5	2,8 2,0	6,6 2,8	0,04250	150	900 3000	800	750	94,5
FDA132MB4/12	3,30 1,10	1430 470	0,79 0,69	8,3 5,3	2,2 1,7	6,5 2,8	0,05150	150	900 3000	800	750	103,5
FDA160MB4/12	4,80 1,60	1400 470	0,80 0,44	10,8 11,0	2,8 2,5	6,8 2,8	0,09700	175	600 1800	800	750	145
FDA160LA4/12	7,30 2,40	1400 470	0,82 0,42	16,2 16,7	2,6 2,3	7,00 3,00	0,12300	175	600 1800	800	750	170
FDA160LB4/12	9,00 3,00	1400 470	0,84 0,42	20,0 20,5	2,9 2,4	7,00 3,00	0,14330	175	600 1800	800	750	180

3) The braking torque values can be reduced of about 10% if the electromagnet is DC.

4) All motors 4/12 poles must be used in S3 duty.

5) We suggest the use of dual metal or ptc protections for 4-12 and 4-16 poles motors.

*Three phase 4-12 poles - 1500/500 Min.-1  
hoisting application*

Type	kW S4 40%-25%	I n V.400
FDA71C4/12	0,20 0,08	1,2 0,8
FDA80C4/12	0,55 0,18	1,7 1,2
FDA90LB4/12	0,8 0,3	2,5 2,2
FDA100LB4/12	1,7 0,6	3,4 2,9
FDA112MB4/12	3,2 1,1	7,9 5,5
FDA112MC4/12	4,5 1,5	11 6,5
FDA132MB4/12	7,5 2,5	16 8
FDA160LB4/12	9,5 3,2	22 21

- 3) The braking torque values can be reduced of about 10% if the electromagnet is DC.
- 4) The 4/12 poles for hoisting must be used in S4 duty.
- 5) We suggest to use of dual metal or ptc protections for 4-12 and 4-16 poles motors.

*Three phase 4-16 poles - 1500/375 r.p.m.  
hoisting application*

Type	kW S4 40%-20%	I n V.400
FDA112MB4/16	1,6 0,4	4,6 3,8
FDA132SA4/16	3,00 0,75	7,2 5,6
FDA132MA4/16	4,00 1,00	9,5 7,5
FDA132MB4/16	5,20 1,30	13,8 12,0
FDA160MB4/16	6,80 1,70	18,0 15,0
FDA160LA4/16	9,00 2,20	23,0 21,0
FDA160LB4/16	10,5 2,60	24,0 22,0
FDA180LB4/16	13,0 3,20	32,5 17,8
FDA200LB4/16	16,0 4,00	40,0 22,0

- 3) The braking torque values can be reduced of about 10% if the electromagnet is DC.  
5) We suggest to use dual metal or ptc protections for 4-12 and 4-16 poles motors.

## Overall dimensions

### B3

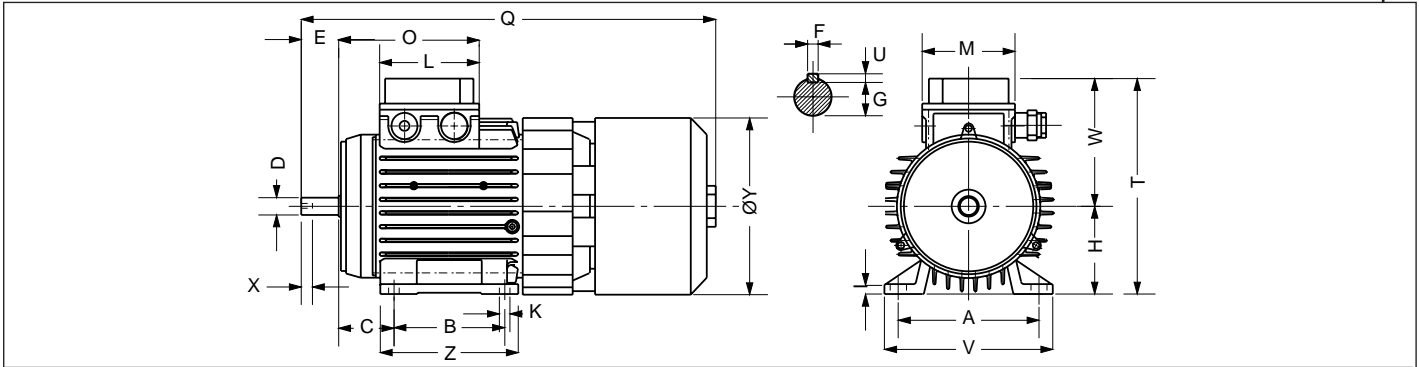

Type	A	B	C	D	E	F	G	H	K	L	M	Q	T	O	W	Y	U	X	V	Z
F 71	112	90	45	14	30	5	11	71	7	81	75	330	173	148	102	141	5	M5	134	108
F 80	125	100	50	19	40	6	15,5	80	7	81	75	370	194	162	114	157	6	M6	156	126
F 90 S	140	100	56	24	50	8	20	90	9	98	99	415	218	174	128	179	7	M8	176	128
F 90 L	140	125	56	24	50	8	20	90	9	98	99	440	218	196	128	179	7	M8	176	151
F 100	160	140	63	28	60	8	24	100	9	98	99	491	241	218	141	179	7	M8	196	166
F 112	190	140	70	28	60	8	24	112	12	98	99	530	263	226	151	220	7	M8	230	166
F 132 S	216	140	89	38	80	10	33,5	132	12	120	110	618	329	257	197	255	8	M10	262	166
F 132 M	216	178	89	38	80	10	33,5	132	12	120	110	658	329	297	197	255	8	M10	262	205
F 160 M	254	210	108	42	110	12	37,5	160	14	180	140	771	386	331	226	314	8	M12	306	240
F 160 L	254	254	108	42	110	12	37,5	160	14	180	140	811	386	371	226	314	8	M12	306	284
F180M	279	241	121	48	110	14	42,5	180	15	200	200	900	455	220	275	314	9	M16	355	300
F180L	279	279	121	48	110	14	42,5	180	15	200	200	910	455	220	275	314	9	M16	355	300
F200L	318	305	133	55	110	16	49	200	19	230	230	950	545	240	345	314	10	M16	395	320

### B5

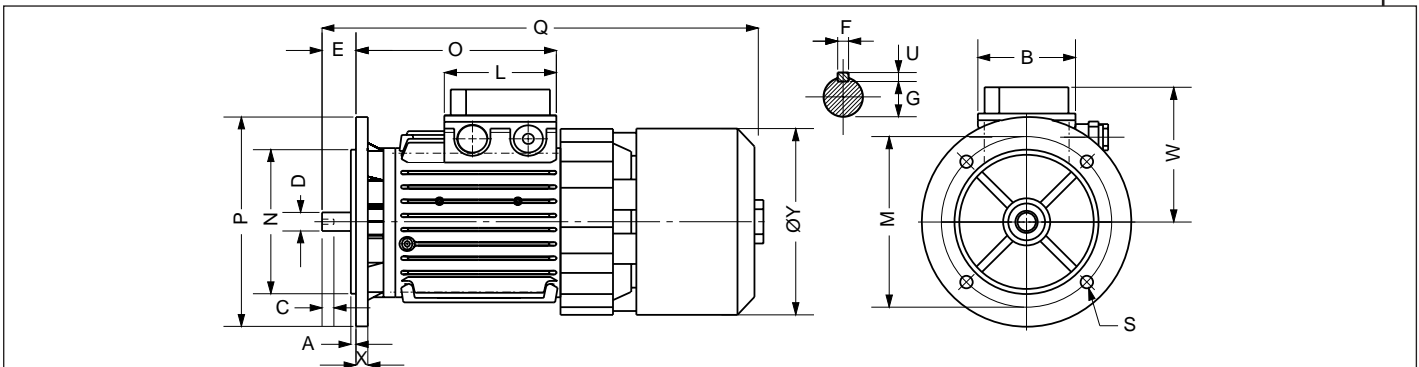

Type	N	B	C	D	E	F	G	H	P	I	L	M	O	Q	S	U	A	X	W	Y
F 71	110	75	M5	14	30	5	11	-	160	-	81	130	148	330	9,5	5	3,5	10	102	141
F 80	130	75	M6	19	40	6	15,5	-	200	-	81	165	162	370	11,5	6	3,5	12	114	157
F 90 S	130	99	M8	24	50	8	20	-	200	-	98	165	182	415	11,5	7	3,5	12	128	179
F 90 L	130	99	M8	24	50	8	20	-	200	-	98	165	207	440	11,5	7	3,5	12	128	179
F 100	180	99	M8	28	60	8	24	-	250	-	98	215	218	483	14	7	3,5	14	141	179
F 112	180	99	M8	28	60	8	24	-	250	-	98	215	229	519	14	7	3,5	14	151	222
F 132 S	230	110	M10	38	80	10	33,5	-	300	-	120	265	260	618	14	8	3,5	14	197	255
F 132 M	230	110	M10	38	80	10	33,5	-	300	-	120	265	300	658	14	8	3,5	14	197	255
F 160 M	250	140	M12	42	110	12	37,5	-	350	-	140	300	330	771	18	8	4	16	250	314
F 160 L	250	140	M12	42	110	12	37,5	-	350	-	140	300	330	811	18	8	4	16	250	314
F180M	250	200	M16	48	110	14	42,5	-	350	-	200	300	220	900	18	9	5	16	275	314
F180L	250	200	M16	48	110	14	42,5	-	350	-	200	300	220	910	18	9	5	16	275	314
F200L	300	210	M16	55	110	16	49	-	400	-	210	350	240	950	18	10	5	18	345	314

Overall dimensions for the double boxes are indicated in the dimension table for B14 constructive form

## Overall dimensions

### B14

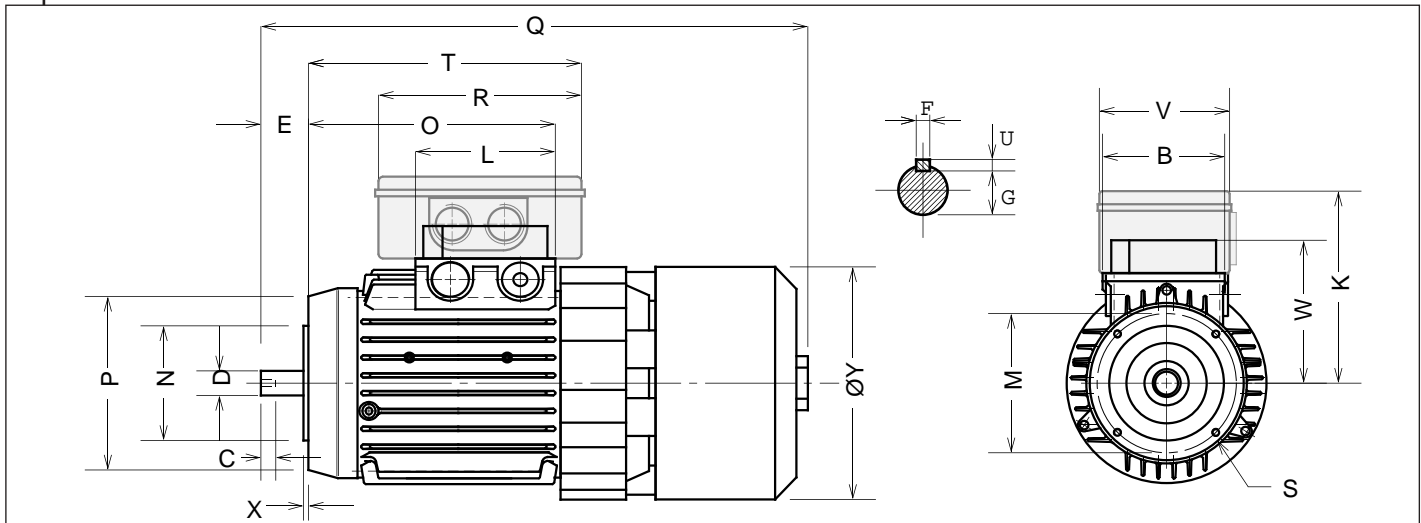

Type	N	B	C	D	E	F	G	H	P	I	L	M	O	Q	S	U	X	Z	W	Y	T	R	V	K
F 71	70	75	M5	14	30	5	11	-	105	-	81	85	148	330	M6	5	3,5	-	102	141	172	128	83	107
F 80	80	75	M6	19	40	6	15,5	-	120	-	81	100	162	370	M6	6	3,5	-	114	157	185,5	128	83	116
F 90 S	95	99	M8	24	50	8	20	-	140	-	98	115	171	415	M8	7	3,5	-	128	179	202	160	107	131
F 90 L	95	99	M8	24	50	8	20	-	140	-	98	115	196	440	M8	7	3,5	-	128	179	227	160	107	131
F 100	110	99	M8	28	60	8	24	-	160	-	98	130	218	480	M8	7	3,5	-	141	180	249	160	107	141
F 112	110	99	M8	28	60	8	24	-	160	-	98	130	226	519	M8	7	3,5	-	151	222	257	160	107	151
F 132 S	130	110	M10	38	80	10	33,5	-	200	-	120	165	260	618	M10	8	3,5	-	197	263	-	-	-	-
F 132 M	130	110	M10	38	80	10	33,5	-	200	-	120	165	300	658	M10	8	3,5	-	197	263	-	-	-	-

### B5 reduced

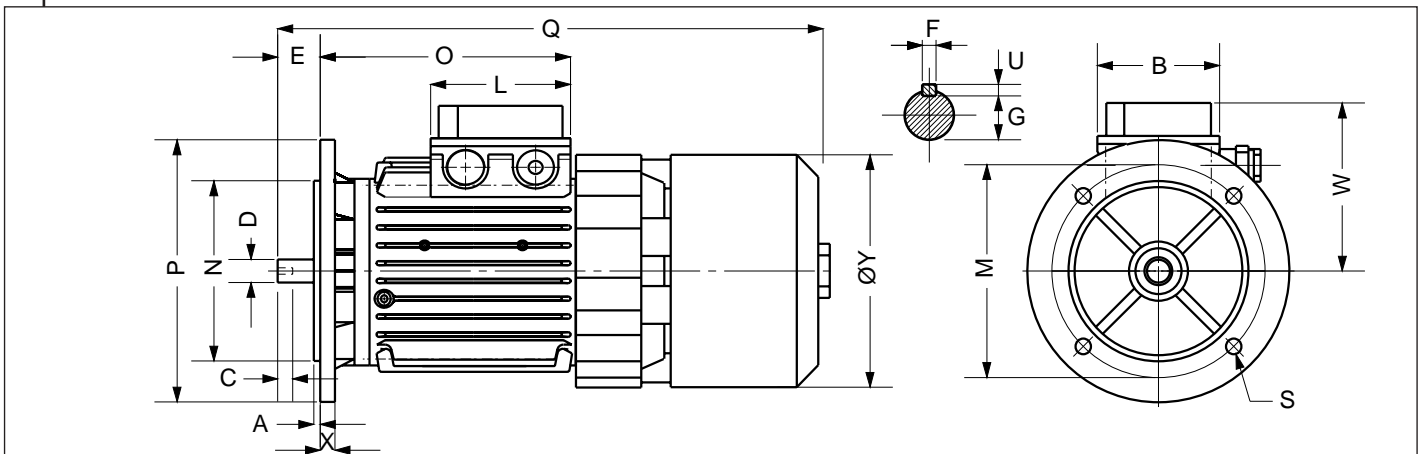

Type	P	B	C	D	E	F	G	S	N	X	L	M	O	Q	T	U	A	W	Y
F 71	140	75	M5	11	23	4	8,5	9,5	95	10	81	115	163	330	-	4	2,5	102	141
F 80	160	75	M6	14	30	5	11	9,5	110	10	81	130	187	367	-	5	3,5	114	157
F 90 S	200	99	M8	19	40	6	15,5	11,5	130	12	98	165	171	430	-	6	3,5	128	179
F 90 L	200	99	M8	19	40	6	15,5	11,5	130	12	98	165	196	455	-	6	3,5	128	179
F 100	200	99	M8	24	50	8	20	11,5	130	14	98	165	248	493	-	7	3,5	141	180
F 112	200	99	M8	24	50	8	20	11,5	130	14	98	165	261	530	-	7	3,5	151	222
F 132 S	250	110	M10	28	60	8	24	14	180	15	120	215	325	660	-	7	3,5	197	263
F 132 M	250	110	M10	28	60	8	24	14	180	15	120	215	370	670	-	7	3,5	197	263
F 160 M	300	140	M12	38	80	10	33,5	18	230	18	140	265	345	800	-	8	3,5	250	316
F 160 L	300	140	M12	38	80	10	33,5	18	230	18	140	265	345	890	-	8	4	250	316